

# AODPC Series

## Multi-Purpose & Water-Proof Panel PC

12" Multi-Purpose & Water-Proof Panel PC with Intel Core 2 Duo Processor  
 Model: AODPC1210A1-C2D-TR



### Features

- Onboard Intel® Core™ 2 Duo Processor
- 12.1" SVGA Color TFT LCD Display
- IP-65 Water-Proof Sealing Enclosure
- Sunlight-Viewable Display With Low Reflection
- Windows®2000, XP Pro, XP Embedded Support
- Day And Night Mode Display
- Ideal For Vehicle Application
- Supports Wireless LAN With Internal Dual Antennas (Optional)
- Water-Proof I/O Connector (IP-67 Rating)

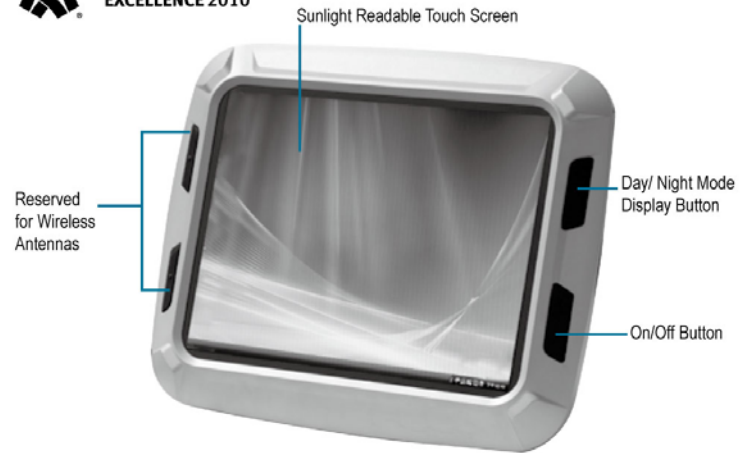

### Specifications

System	
Processor	Intel® Core™ 2 Duo U7500 1.06 GHz Processor
System Memory	DDR II SODIMM x 1, Max. 2 GB
LCD/CRT Controller	Intel® 945GM
Ethernet	GbE LAN, RJ-45 x 1 (optional)
Expansion Slot	Mini-PCI Slot x 1 (internal)
Water-Proof I/O Port	RS-232 x 1, RS-232/422/485 x 1, USB2.0 x 2 Audio Line-out (optional)
Storage Disk	SATA/IDE 2.5" Hard Disk Drive bay (Anti-vibration)/ CompactFlash™ (internal)
OS Support	Windows® 2000, Windows® XP Pro for Embedded, Windows® XP Embedded, Windows® 7
Mechanical	
Construction	Sealed Aluminum Alloy Chassis
Color	Silver Gray
Mounting	VESA 75/100mm
Dimension	13.58" x 11.1" x 2.36" (345mm x 282mm x 60mm)
Carton Dimension	20.24" x 9.72" x 20.71" (514mm x 247mm x 526mm)
Gross Weight	12.1 lb (5.5 kg)
Net Weight	9.9 lb (4.5 kg)
Environmental	
Operating Temperature	-4°F ~ 122°F (-20°C ~ 50°C )
Storage Temperature	-22°F ~ 158°F (-30°C ~ 70°C )
Storage Humidity	10 ~90%@35°C, non-condensing
Vibration	3G Random Operation, 5~500Hz
Shock	30G peak acceleration (11m sec. duration) / operation
Safety	All sides of IP-65 Certified
EMC	CE/FCC Class A
Power Supply	
DC-DC Input, 90W	Input Range: 9V ~ 30V DC
LCD	
Display Type	12.1" TFT- LCD
Max. Resolution	800 x 600
Max. Color	262K colors
Dot Size	0.3075 x 0.3075
Luminance (Typical)	450 cd/m2
View Angle	140°(H)/110°(V)
Back Light MTBF (Hours)	50,000

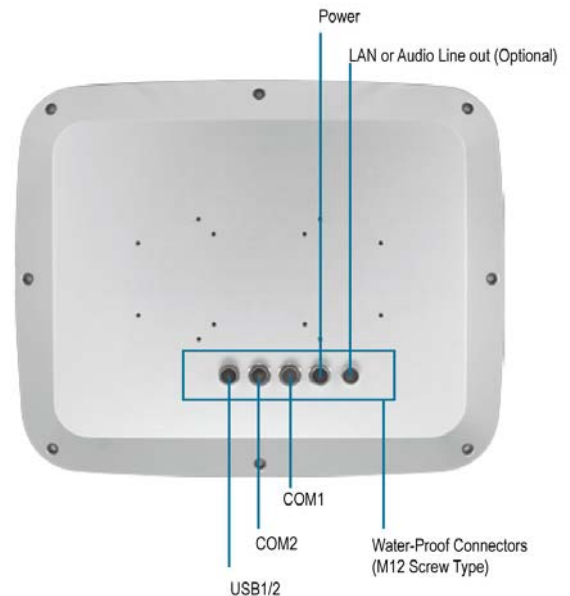

Touchscreen	
Type	8-wire, Low Reflection Analog Resistive/ 5-wire, Analog Resistive
Resolution	2048 x 2048
Light Transmission	> 76% (8-wire analog resistive) > 80% (5-wire analog resistive)
Lifetime	2 million activations (8-wire analog resistive) 35 million activations (5-wire analog resistive)



## Dimensions

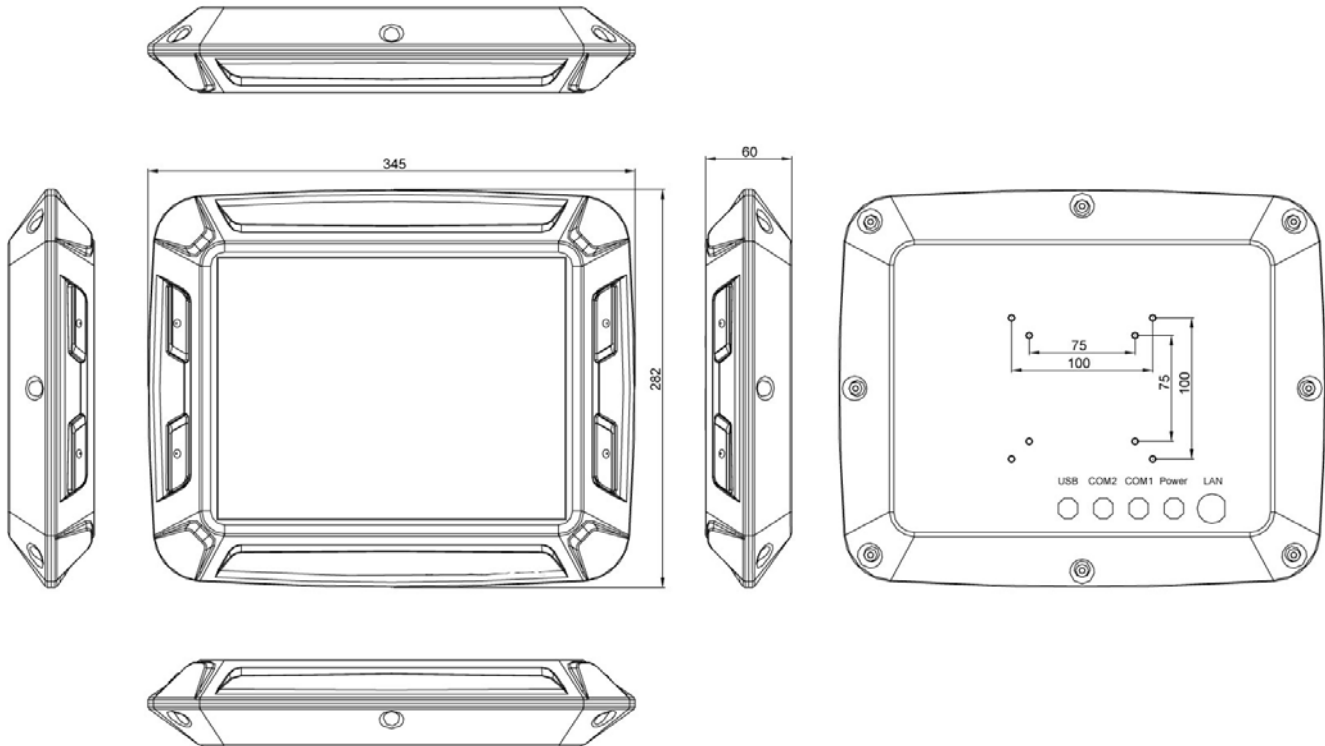

## Optional Accessories

- 9761F15000**  
Wireless LAN Kits with Internal Antenna
- 1757910004**  
AC Adapter (100W)
- 9783204012**  
2.5" 40 GB Automotive Hard Disk Drive
- 968C204859**  
2 GB Wide Temperature CompactFlash™ Disk Drive
- 968C409654**  
4 GB Wide Temperature CompactFlash™ Disk Drive
- 968C819215**  
8 GB Wide Temperature CompactFlash™ Disk Drive
- 968C016G06**  
16 GB Wide Temperature CompactFlash™ Disk Drive
- 1702031802**  
Power Cord (US Type) For Adapter
- 1702031803**  
Power Cord (European Type) for Adapter
- 170203180E**  
Power Cord (Japanese Type) for Adapter
- STAND-FOXSO**  
Desktop Stand