

AODPC Series

Multi-Purpose & Water-Proof Panel PC

IP-65, 15" Multi-Purpose & Water-Proof Panel PC with Intel Atom N270 Processor

Model: AODPC1500A1-AT



Features

- Onboard Intel® Atom™ N270 1.6 GHz Processor
- 15" XVGA Color TFT LCD
- IP-65 Water-Proof Sealing Enclosure
- Sunlight-Viewable Display With Low Reflection Touch Screen
- Windows® XP Embedded, Windows® 7 Support
- Day And Night Mode Display
- Optical Bonding LCD
- Ideal For Vehicle Applications
- Supports Wireless LAN With Dual Internal Antennas (Optional)
- Water-Proof I/O Connector (IP-67 Rating)



Specifications

System	
Processor	Intel® Atom™ N270 1.6 GHz Processor
System Memory	DDR II SODIMM x 1, Max. 2 GB
LCD/CRT Controller	Intel® 945GSE
Ethernet	10/100/1000 Base-TX, RJ-45 connector x 1 (optional)
Water-Proof I/O Port	RS-232 x 1, RS-232/422/485 x 1, USB 2.0 x 2, Audio Line out x 1 (optional)
Storage Disk	SATA/IDE 2.5" Hard Disk Drive Bay (Anti-vibration)/ CompactFlash™ (Internal)
OS Support	Windows® XP Pro for Embedded, Windows® XP Embedded, Windows® 7
Mechanical	
Construction	Sealed Aluminum Alloy Chassis
Color	Silver Gray
Mounting	VESA 75/100mm
Dimension	16.14" x 14.41" x 2.36" (410mm x 366mm x 60mm)
Gross Weight	19.8 lb (9 kg)
Net Weight	16.5 lb (7.5 kg)
Environmental	
Operating Temperature	-4°F ~ 122°F (-20°C ~ 50°C)
Storage Temperature	-4°F ~ 158°F (-20°C ~ 70°C)
Storage Humidity	10 ~90%@35°C, non-condensing
Vibration	3G Random Operation, 5~500Hz
Shock	30G peak acceleration (11m sec. duration) / operation
Safety	All sides of IP-65 Certificated
EMC	CE/FCC Class A
Power Supply	
DC-DC Input, 90W	Input Range: 9V ~ 30V DC
LCD	
Display Type	15" TFT- LCD
Max. Resolution	1024 x 768
Max. Color	16.7M colors
Dot Size	0.297 x 0.297
Luminance (Typical)	450 cd/m2
View Angle	160°(H)/160°(V)
Back Light MTBF (Hours)	50,000

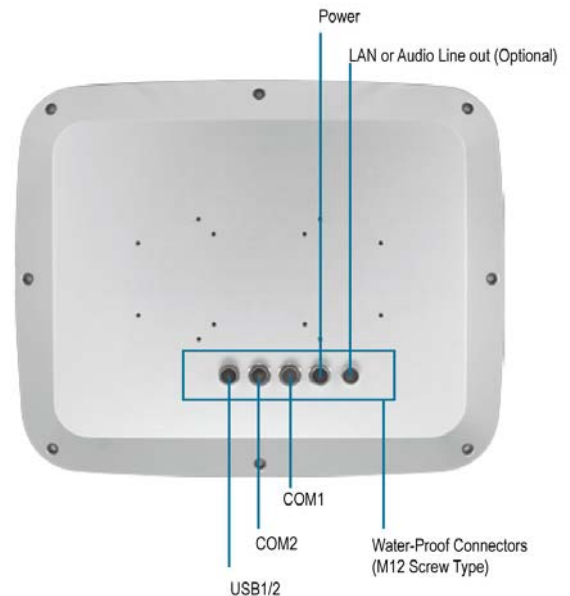

Touchscreen	
Type	Low Reflection Analog Resistive (FOX-151STT) 5-wire, Analog Resistive (FOX-151HTT)
Resolution	2048 x 2048
Light Transmission	> 74% (8-wire analog resistive) > 80% (5-wire analog resistive)
Lifetime	2 million activations (8-wire analog resistive) 35 million activations (5-wire analog resistive)



Dimensions

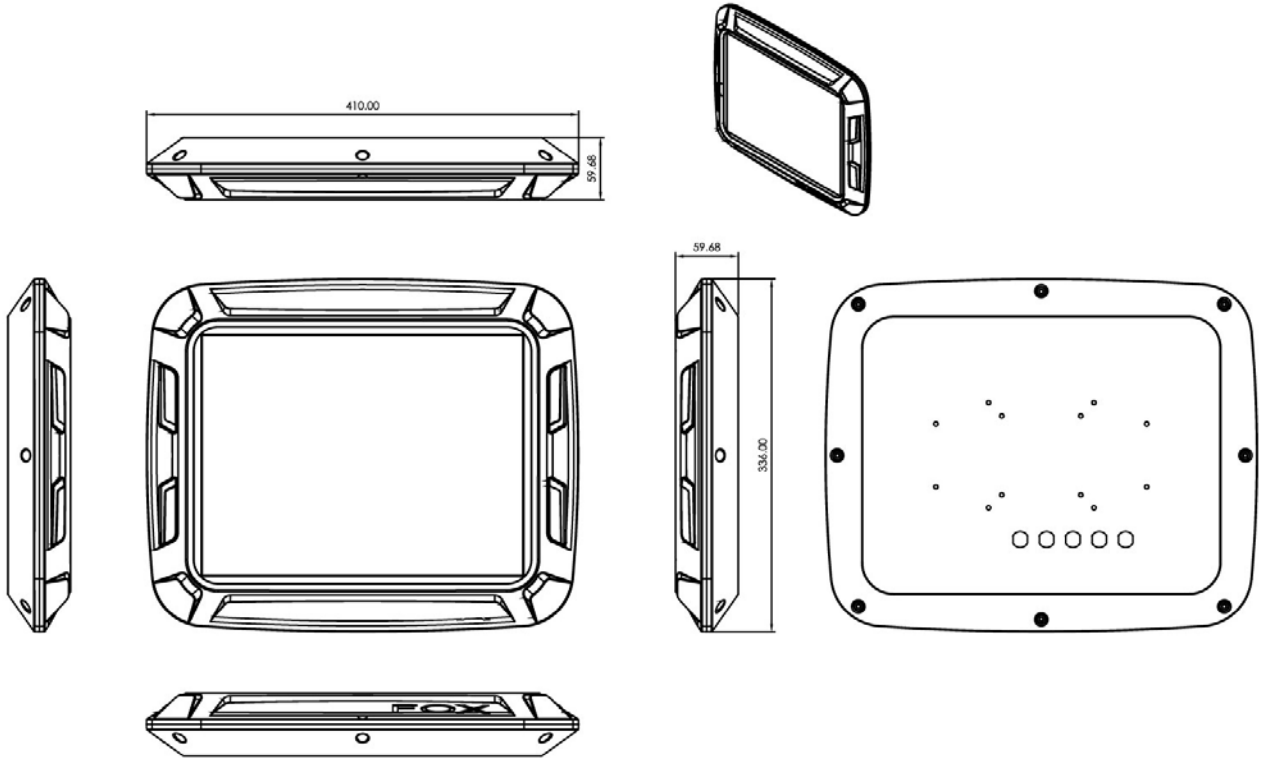

Optional Accessories

- **9761F15000**
Wireless LAN kits with Internal Antenna
- **1757910004**
AC Adapter (100W)
- **9783204012**
2.5" 40 GB Automotive Hard Disk Drive
- **968C204859**
2 GB Wide Temperature CompactFlash™ Disk Drive
- **968C409654**
4 GB Wide Temperature CompactFlash™ Disk Drive
- **968C819215**
8 GB Wide Temperature CompactFlash™ Disk Drive
- **968C016G06**
16 GB Wide Temperature CompactFlash™ Disk Drive
- **1702031802**
Power Cord (US Type)
- **1702031803**
Power Cord (European Type)
- **170203180E**
Power Cord (Japanese Type)
- **STAND-FOXS0**
Desktop Stand