

PC Based Industrial Compact Size PANEL PC

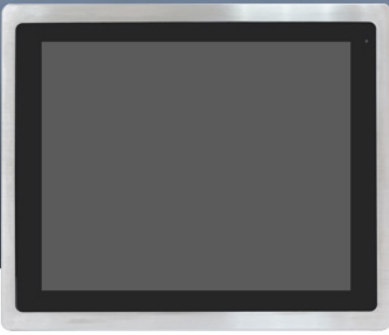

15" XGA 1000nits Optical Bonding IP66/IP69K stainless steel panel pc, Free scale i.MX6 Dual Lite ARM Cortex A9,1GB DDR3 RAM,4GB eMMCe, projected capacitive touch, 9~36V DC power input with Adapter Accessory : 1 x M12 USB Cable WT(-20~60C) (12.1in, 15in) for Panel PC, HMI, & Display Certification CE / FCC CLASS A /UL60950

MODEL: APC1500HBWT-AM

FEATURES:

- 15" New Generation Stainless Steel Panel PC
- Freescale I.MX6 DualLite 1.0GHz Onboard Processor
- True Flat Front Bezel Design and Grade 304 Stainless Steel Enclosure (Grade 316 for Option)
- IP66/IP69K Rated with M12 Connectors
- Support Resistive Touch, Projected Capacitive Touch, and Glass
- Touch on/off Button on the Side Edge for Hygienic Cleaning
- Support Ergonomic Versatile Mounting: Yoke Mounting / Space-saving VESA 75 x 75 mm Mounting



SPECIFICATION:

SYSTEM	
CPU	Freescale i.MX6 Dual Lite, ARM Cortex A9(2x Cores, 1.0GHz)
System Memory	Onboard 1GB DDR3 SDRAM
System Chipset	SoC
IO Port	
USB	1 x M12 8-pin for 2 x USB 2.0 with waterproof cover and chain
Serial/Parallel	1 x M12 8-pin COM1, RS-232/422/485, default RS-232, with waterproof cover and chain
LAN	1 x M12 8-pin for LAN with waterproof cover and chain (POE for option)
Others	1 x Touch on/off button on the side
Power Connector	1 x M12 3-pin for DC power with waterproof cover and chain 1 x Power switch on the side
Options	2 x M12 blank for option 1 x CAN 1 x PoE
Storage Space	
HDD	Onboard 4GB eMMC NAND Flash
Expansion	
Expansion Slot	1 x miniPCle slot for WIFI/BT(optional), 4G/LTE(optional)
RFID module	RFID module design on the front side(optional)
Display	
Display Type	15" TFT-LCD
Max. Resolution	1024 x 768
Max. Color	262K / 16.2M (optional)
Brightness	1000
View Angle	160(H) / 160(V)
Contrast	1000:1
Backlight Lifetime	30,000 hrs

TOUCHSCREEN (option)	
Type	Projected Capacitive Touch
Light Transmission	Resistive Touch : 80% / Projected Capacitive : 90%
Interface	SPI(Resistive Touch) / USB(Projected Capacitive Touch)
POWER SUPPLY	
Power Input	DC 9~36V
Power Consumption	12W
MECHANICAL	
Construction	304 Stainless steel front bezel (Default) 316 Stainless steel front bezel (Optional) Aluminum back cover
IP Rating	Front Panel IP66/IP69K
Mounting	VESA mount 75 x 75, Yoke mount (optional)
Dimension	399 x 324 x 53 mm
Net Weight	7.1 kg
ENVIRONMENTAL	
Operating Temperature	-20~60°C
Storage Temperature	-20~60°C
Storage Humidity	10 to 90%@ 40°C, non-condensing
Certificate	Certification CE / FCC CLASS A / UL60950
Operating System Support	
Android 6.0.1 / Linux 4.1.15	



i-Tech Company LLC

TOLL FREE: (888) 483-2418 • EMAIL: info@iTechLCD.com • WEB: www.iTechLCD.com

DIMENSION:

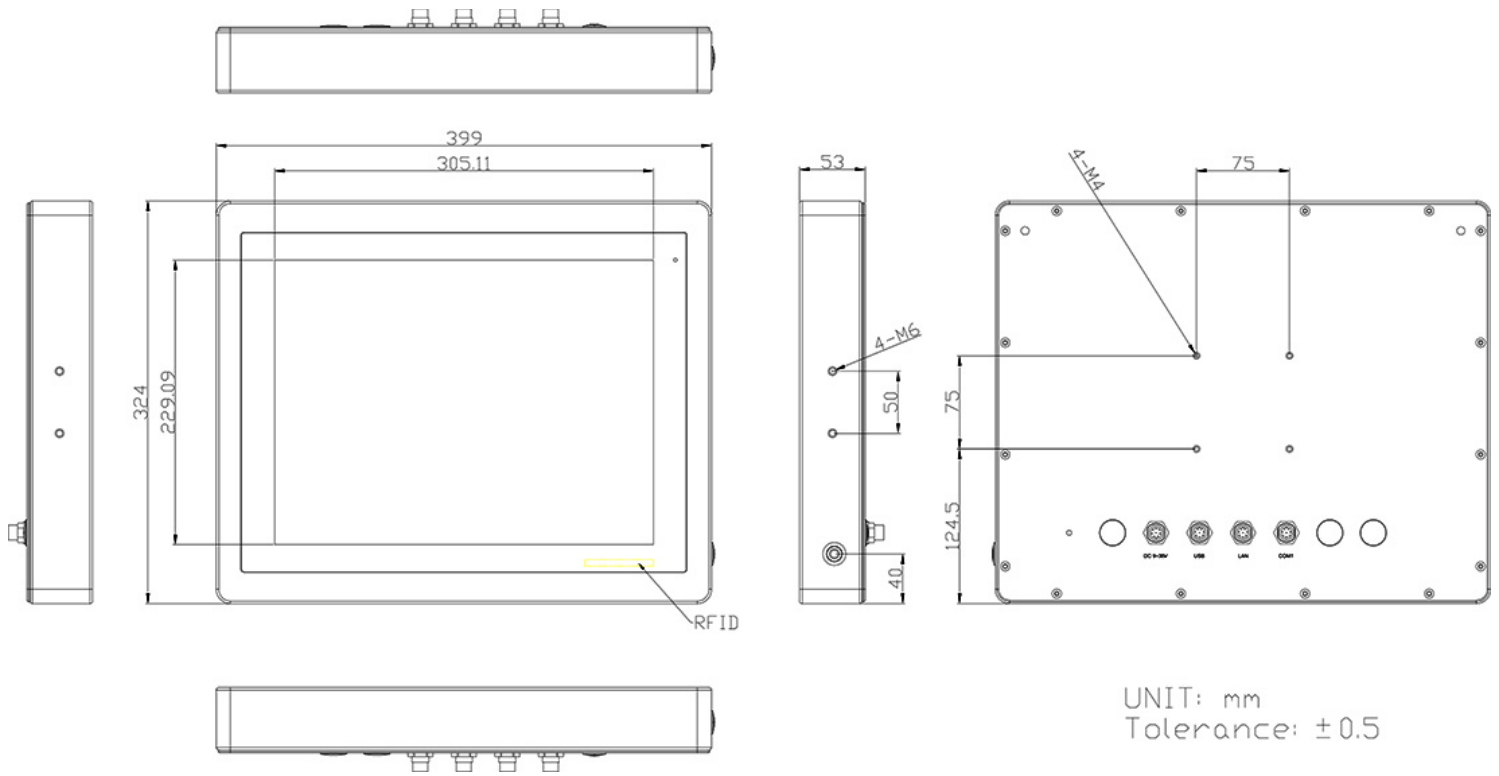

UNIT: mm
Tolerance: ± 0.5