

MILITARY RUGGED RACKMOUNT LCD DRAWER



1U 19" Rackmount Rugged LCD Keyboard drawer 1280 x 1024, 400nits, Durable 104-key waterproof keyboard, Front air bonded EMI glass, AC 110/220V input, Short Depth 660mm Deep /26" deep extend to 1100mm 43", No Speaker

Video input: DISPLAYPORT 1.2, DVI-D, *VGA
 Operation temp: -20 to 55C
 Storage temp: -30 to 65C
 Humidity: 10% - 90%, non-condensing
 Shock: 10G acceleration (11ms duration)
 Vibration: 17 to 500Hz 1G PTP
 MTBF : 50000hours
 Includes cables 1.8meter DVI-D Cable and 1.8M USB cable & Power cables.



USB Port for Device Access

Model: AMil-1900-EMI-AC-DP

FEATURES

- Meet MIL-STD-810F/G standard
- 1U 19" LCD Console Drawer, wide operation temperature support 1280 x 1024 resolution
- DVI, DP & VGA Port
- Front 1x USB, Rear 1x USB 2.0 Type A, Sharing USB peripheral Device for computer (ex, flash disk, hard driver, KB/Mouse)
- Sealed 104-keys IP65 silicone keyboard and touchpad with backlight
- MIL connector for power input
- Support USB 2.0 Keyboard & Mouse
- With hardness glass protect screen
- Self-locking and auto release rails for ultra convenience

Option

- HDMI Input
- DC 9~36V power input
- High brightness LCD panel, up to 1000 nits
- Front AR or EMC glass protect screen
- Touch screen

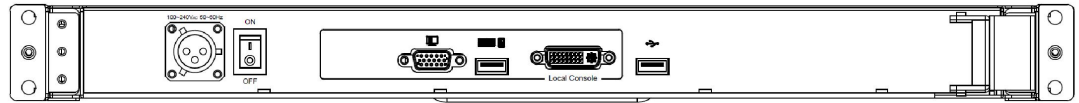

REAR VIEW

SPECIFICATIONS

Direct no. of Computers	1	
LCD	Size	19"
	Backlight	LED
	Resolution	1280x1024
	Max. color	16.7M
	Luminance	400cd/m2
	View Angel (H/V)	170 / 160
	Contrast Ratio	1000 : 1
USB HUB	1x Front , 2xRear USB 2.0 Type A for Peripheral USB Device	
Touch Screen	Yes, for option	
KB/Mouse Emulation	USB	
Rack Depth	660mm to 1100mm (rack cabinet front rails to rear rails)	
Power	100-240V AC 50/60Hz via 4 pins lock connector	
Environment (MIL-STD-810G)	Operation temp: -20 to 55°C	(MIL-STD-810, Method 501.5 & 502.5)
	Storage temp: -30 to 65°C	(MIL-STD-810, Method 501.5 & 502.5)
	Humidity: 10% - 90%, non-condensing	(MIL-STD-810, Method 507.5)
	Shock/Vibration: Procedure VI, 50G @ 11ms	(MIL-STD-810, Method 516.6)
	Altitude: 10,000 ft Operational, 30,000 ft Storage	(MIL-STD-810, Method 500.5)
Physical Dimensions / Net Weights	482x42x600mm (WxHxD) /13KG	
Packing Dimensions / Gross weights	720x160x860mm(WxHxD) /19KG	
Accessory		
1 x 1.8 Power Cord with lock connector, 1.8 meter DVI-D Cable, 1.8 meter VGA Cable , 1.8 meter USB Cable (each one)		

*Specifications subject to change without notice, not responsible for typographical errors.

Modified Date: 03-10-2023

MECHANICAL DRAWINGS

This is subject to change without Notice. Final Drawings will be provided for Approval after Order.

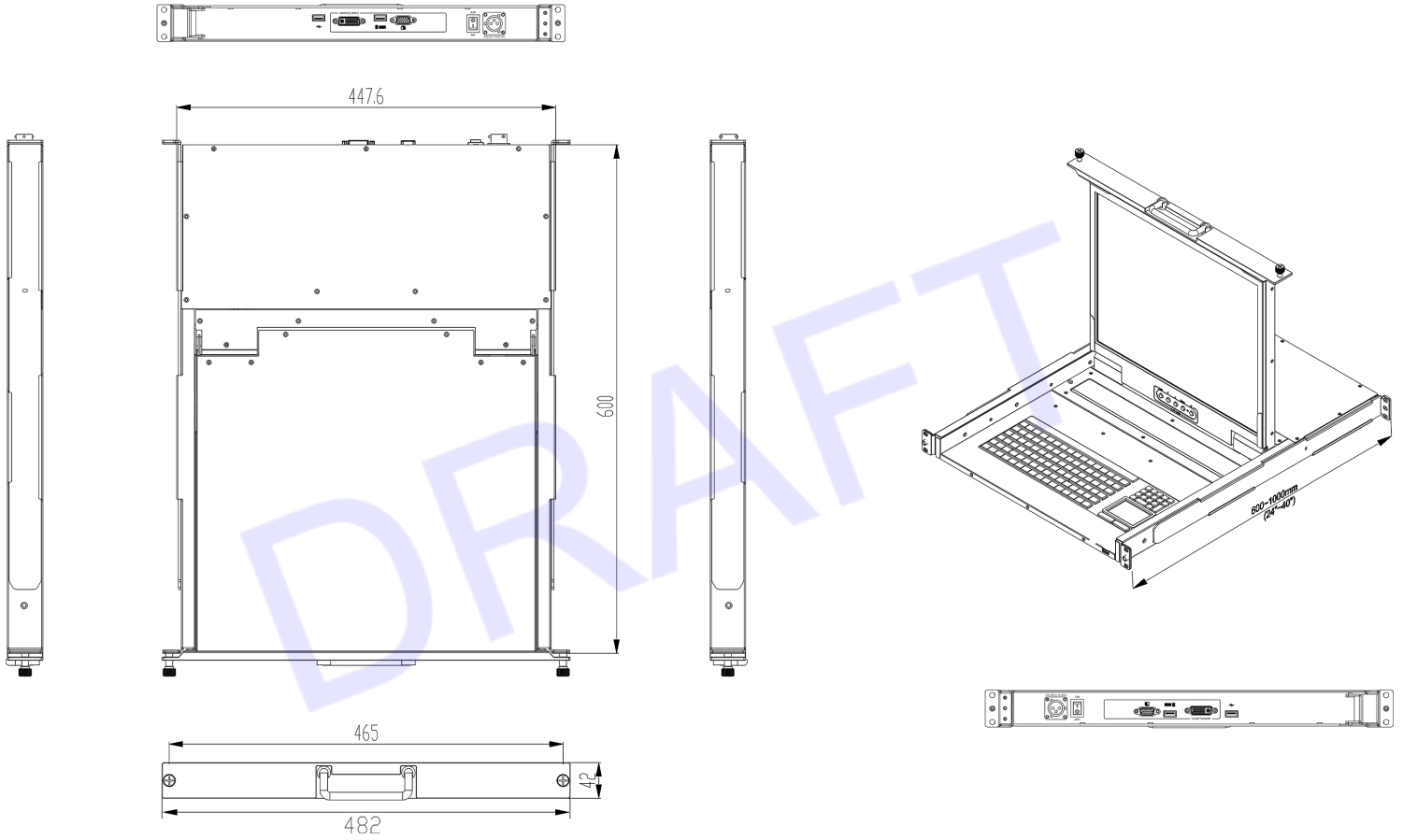

Drawing no.: AMil-1900-EMI-AC-DP-03102023-V1