



Model : DKP117e

17" 1U Rack Mount TFT Console

Features:

- Single Rail easy to install and use
- Support 15 various keyboard languages
- Bright Active Matrix TFT Display
- OSD function (On Screen Display) for LCD display
- Durable keyboards (touchpad or trackball)
- Panel protected by tempered glass
- Support USB K/B, touchpad (optional)
- Audio Function (optional)
- DC power (optional)
- Support DVI (optional)



Specification

Model Name	DKP117e
Number of ports	1
Dimension	447.5x482x44mm/17.6x19.0x1.7in
Package Dimension	565x660x210mm/22.2x26.0x8.3in
Net Weight	13.0Kg / 28.7Lb
Gross Weight	17.0Kg / 37.5Lb
Display Size	17"
Panel Type	Active Matrix TFT LCD
Resolution Capabilities	Maximum Resolution up to 1280X1024 (SXGA)
Pixel Pitch	Supports 0.264mm x0.264mm
Viewing Angle (CR>10)	Right-Left view 60°~70°(Typ)
Contrast Ratio	450:1
Brightness	White 250cd/m2 (Center 1 point Typ)
Back Light	Four Lamps for Back Light
Supported Colors	16.2M Colors (6-bit with FRC)
Response Time	Rising Time 2ms, Decay Time 14ms
Operating System	Dos, Windows (3.1, 9x, 2000, NT4, ME, XP, 2003 Server) Linux, Novell 3.12-6, HP UX, SUN
Multi Platform	Support PS/2
System Cables	VGA+2xPS/2 cable
Keyboard Mouse	106 key PS/2 keyboard with touch pad
Sync	45~80KHZ
Power Source	100-240 VAC input
Power Consumption	25W, 19.05W for Panel
Temperature	Operate 0°~ 50°C / 32°~ 122°F, Storage-20°~ 60°C / -4°~ 140°F
Humidity	10%~90%RH
Chassis Construction	Heavy duty steel materials
Keyboard Language	Standard USA, Options for (UK, German, French, Spanish, Italian, Portuguese, Dutch, Swiss, Belgium, Swedish, Norwegian, Danish, Japan, Taiwan) CE/FCC, UL/CUL/C-Tick

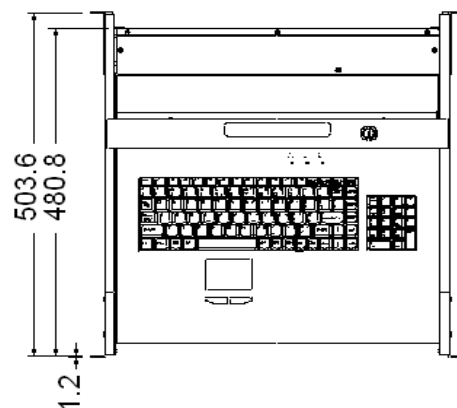
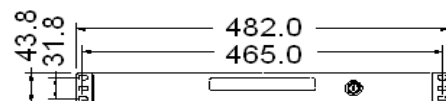
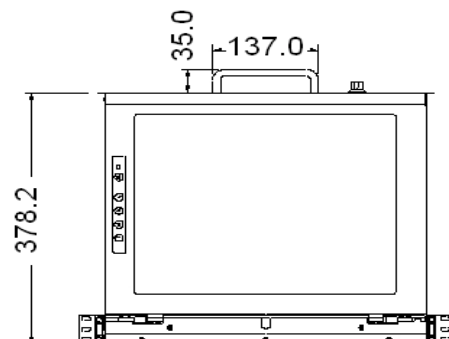
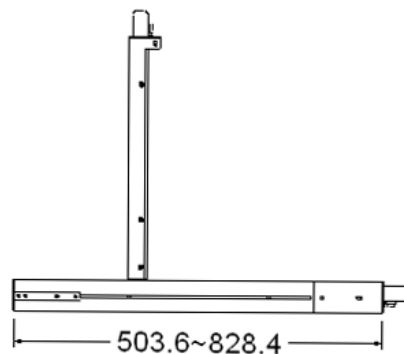

Certification



Toll Free: 1-888-itech-18 USA Phone: 1-510-429-9288 Fax: 1-510-372-2736
E-mail: sales@i-techcompany.com 30081 Ahern Ave Union City. CA94587 USA

www.i-techcompany.com www.i-techcompany.com www.i-techcompany.com www.i-techcompany.com