



Aluminum alloy with rubber corners



Removable 5.25" storage bays



All I/O's are neatly located on left side of the unit



4 or 7 slots expansion capability

### FEATURES:

- Ultra rugged portable workstation
- 17" ultra high resolution 1920x1200, 16:10 display
- Up to 7 full length expansion slots
- Support Intel Core™ 2 Duo and dual Xeon Quad-Core processors
- Tested to meet MIL-STD 810F

### Introduction:

The BPCW1700 is a robust lunchbox computer built using heavy duty sheet metal to provide tough, go-anywhere unit suitable for harsh environments and mission critical applications. With multiple expansion slot options to choose from, the BPCW1700 can be freely configured with other uniquely designed add-on cards for various applications.

To meet the harsh environment operations, the LCD screen of the BPCW1700 is guarded with a specially treated anti-glare tempered glass for added protection. Every BPCW1700 comes equipped with dual system cooling fans and easy access to its expansion slots for immediate system upgrade or maintenance. Functional practicality combined with the rugged construction, the BPCW1700 is the most cost-effective and durable and versatile portable platform for your mission critical applications



Comrade 500

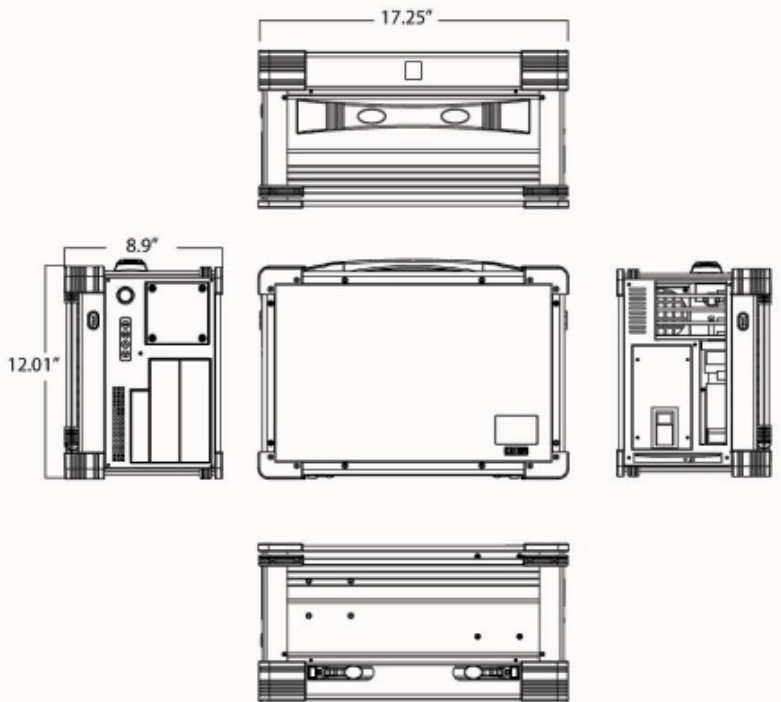

Display	
Diagonal	17", 16:10 Wide Display
LCD Resolution	1440x900(1920x1200)
Brightness	300 nits
Contrast Ratio	500:1
Backlight MTBF	50K Hours

Compliance	
Quality	ISO 9001
Approvals	CE, FCC, CCC, ROHS
Shock	Operating: 10g, 11ms, Half-Sine Non-Op: 30g, 11ms, Half-Sine
Vibration	Operating: 10-500Hz (0.4Grms) Non-Op: 10-500Hz (1.12 Grms)

Specifications			
Model	BPCW1700-DC-3	BPCW1700-DC-4	BPCW1700-XQC-5A BPCW1700-XQC-5B
Chipset	Intel 945GM	Intel Q35	Intel 5100
Slot	1xPCI-E(x16), 1xMini-PCI-E 6xPCI	2xPCI-E, (x16 + x4) 2xPCI	1x PCI-E (x16), 2x PCI-E (x8 + x4) 1xPCI
IDE	1x	1x	No
RAID Internal	Yes(0, 1,5, 10)	Yes(0, 1,5, 10)	Yes(0, 1,5, 10)
CPU	Intel T7400 2.16GHz (Dual Core)	Intel E7400 2.8GHz (Dual Core)	2x Intel Xeon L5410 2.33GHz (Quad Core)
Memory	2GB DDR2 533MHz (max. 4GB)	2GB DDR2 667MHz (max. 8GB)	4GB DDR2 ECC 667MHz REG (max.48GB)
Audio	Yes	Yes	Yes
USB 2.0	4x external	4x external	4x external
LAN	1xGb, 1x 100Mb Intel 82573L	1xGb Intel 82566DM	2x Gb Intel 82573L
Power	400W, 110-220VAC, 50/60Hz	650W, 110-220VAC, 50/60Hz	650W, 110-220VAC, 50/60Hz
VGA	Intel GMA 950 (LVDS)	Intel GMA Q35 (RGB)	XGI Z9S (RGB)
O/S	Window XP Pro	Window XP Pro	Window XP Pro
HDD	1x 500GB SATA 3.5"	1x 120GB SATA 2.5"	1x 120GB SATA 2.5"
Optical	DVD-RW(IDE)	DVD-RW(IDE)	DVD-RW(IDE->SATA)
Drive Bay	2 x 3.5" open	2 x 5.25" + 1 x 3.5" open	2 x 5.25" open
Dimension/ Weight	12.01 "H x 17.25"W x 8.9"D / 26 LBs	12.01 "H x 17.25"W x 8.9"D / 26 LBs	12.01 "H x 17.25"W x 8.9"D / 26 LBs

