

15" 1U Monitor / Keyboard Drawer with Optional KVM Short Depth 20"

Model: DHK1415e

This is a high performance 1U LCD display drawer sporting 15", 17" & 17W LCD Monitors. These monitors have high contrast ratios and wide viewing angles with resolutions at WXGA (1440 x 900) for 17W, SXGA (1280x1024) for the 17" monitors, and XGA (1024x768) for the 15" monitor. The display is stowed flat above the keyboard and tilts up for use. The Clam Shell design is held open with two 30 lbs heavy-duty Torque hinges with a maximum opening of 96 Degs from closed. Ball bearing slides are integrated along with mounting brackets to facilitate the installation in any standard 19" Rack enclosure. The drawer is held closed by keyed cam lock. This configured with many different Keyboard / Pointer combinations to meet almost any combination (See the Integrated Keyboard Reference Guide). This has been designed to allow for multiple back panel termination options including aRGB, integrated 8 and 16 port KVM Switches with OSD functions (See Integrated Back / KVMS Reference Guide). Standard Finish is Black Powder Coated Medium Texture, but it can be customized to any color or logo.

Features:

Enclosure:

- Mounts in standard 19-inch rack cabinets 20 - 36 inch depths.
- Utilizes only 1U (1.75")
- RSI Design (Rapid Start Installation). Less than 5 minutes!
- Rugged all Aluminum light weight construction designed to satisfy Broadcast, Industrial, Commercial and Military requirements.
- Compact enclosure for rackmount and desktop applications.

Display:

- 15 - 17" Diagonal Active Matrix TFT LCD (See RD1U CA20XX Specs Data Sheet)
- Featuring Samsung & LG technologies
- Large viewing area
- Max resolutions to WXGA (1440 x 900) for 17W, SXGA (1280 x 1024 @ 60Hz) for 17", and XGA (1024x768) for 15".

Video Controller:

- Standard Analog RGB input (See V05X Controller in the Video Controller Ref Guide)
- OSD (On Screen Display) Monitor Controls

Keyboard / Pointing Device:

- Many different Keyboard / Pointing Devices to choose from.

Power:

- +12 VDC Operation
- Low power consumption

Other Features / Options:

- Integrated KVM Switch Options
- Front Face Options (B, Ba, C, Ca, D, Da) (A is available on Custom Orders) See Front Face Data Sheet
- Special order options include: Custom Paint and Integrated Touch

Please feel free to consult with a Sales Engineer for additional information or visit our web site.









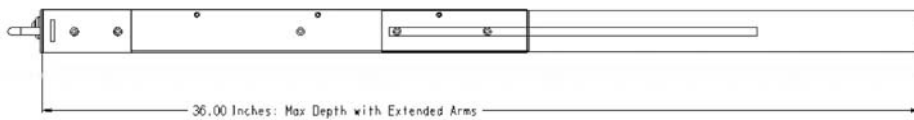
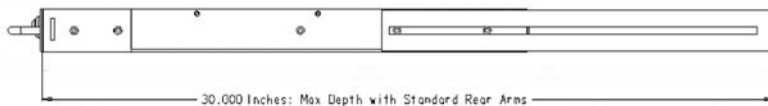
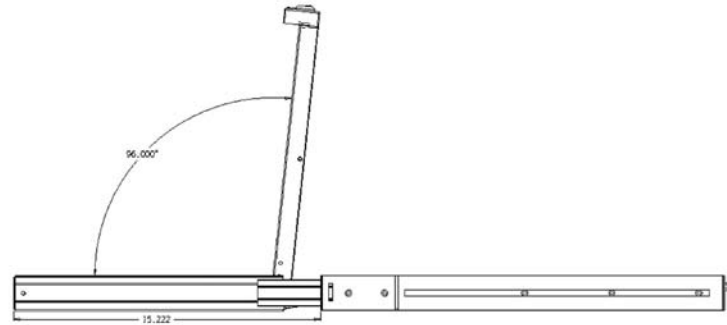
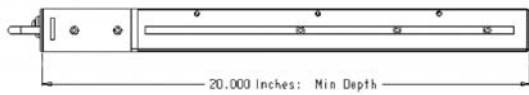
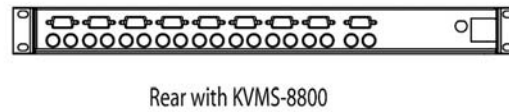
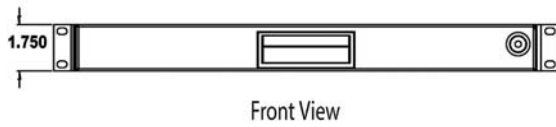
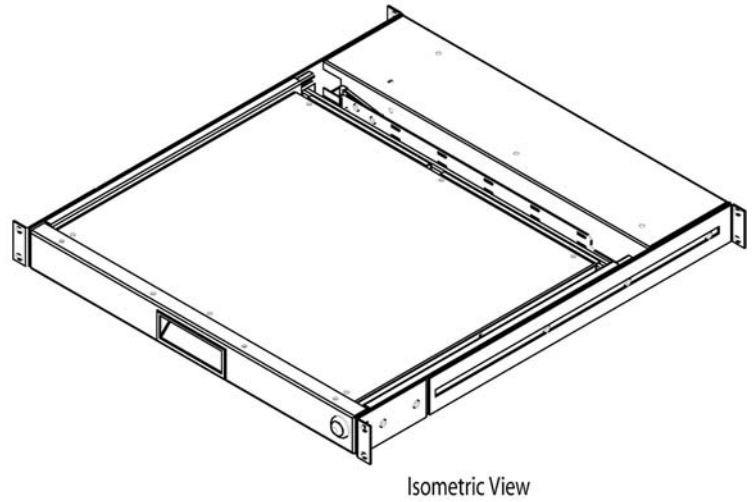
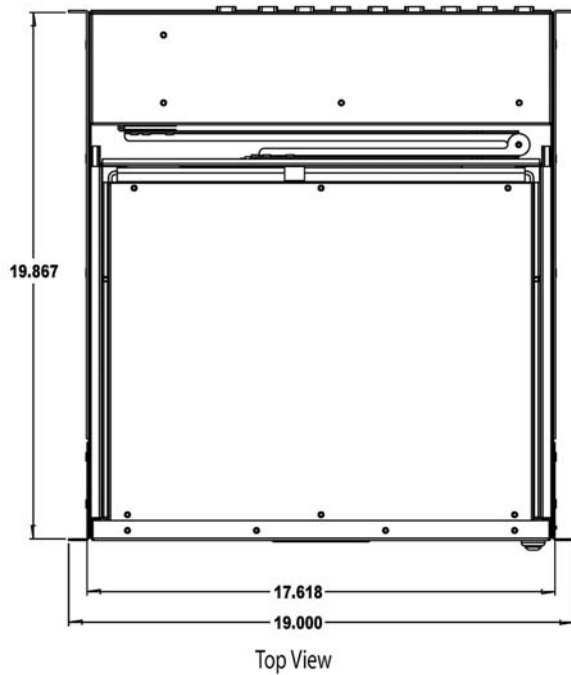



Technical Specifications

Monitor Size	15"	15" Transflected	17" Production	17" Ultra Thin	17.1" Wide
Display Type	XGA, Color, TFT-LCD, 2 CCFL Back Light, Extended road Map	XGA, Color, TFT-LCD, 4 CCFL Back Light, Extended road Map, Transflective, High Bright	SXGA, Color, TFT-LCD, TN, 4 CCFL Backlight,	SXGA, Color, TFT-LCD, PVA, 4 CCFL Backlight, Ultra Thin for Touch	WXGA+, Color TFT-LCD, 2 CCFL Backlights
Max	1024x768	1024x768	1280x1024	1280x1024	1440x900
Aspect Ratio	4:3	4:3	4:3	4:3	16:10
Display Colors	16.78M				
Brightness (Nits)	250	600	300	250	250
Contrast Ratio	500:1	600:1	1000:1	600:1	800:1
Response Time	18	18	1.3	10	2R, 6D
Pixel Pitch	0.297x0.297	0.297 x 0.297	0.264 x 0.264	0.264 x 0.264	0.255 x 0.255
Power	EPA energy star, VESA compliance				
Viewing Angle	80L/80R/80D/60U	80L/80R/80D/60U	80/80/80/80	89/89/89/89	80/80/80/80
MTBF	30,000 - 50,000 hours				
Surface Treatment	AntiGlare Hard Coat	Clear + Antireflection (2H)	Haze 25%, Hard	Haze 44%, Hard	Hard-coating
Temperature	-20 to +70	-10 to +70	0 to +50	0 to +50	0 to +50
Temperature	-20 to +80	-20 to +80	-25 to +60	-25 to +60	-25 to +60
Altitude Operating	16,005	TBD	TBD	0 ~10,000	0 ~10,000
Altitude Storage	44,880	TBD	TBD	0~40,000	0~40,000
Humidity Operating	=<95	=<95	5 to 90	10 to 90	10 to 90
Humidity Storage			5 to 90	10 to 90	10 to 90
Applicable DIT	V051, V052, V053				
Video	Analog RGB				
Keyboards:	A, B, D, E, G, H, I, J, M				
KVM Switches:	A, B, C, D, E, G, H, K, V				
Chassis/ Drawer;					
Mounting	Standard 19-inch rack				
Slide Rails	Pre-integrated / installed with cable management guides for 20 inch depth; standard ball-bearing				
Dimensions	19 x 1.75 x 20-inch min. Can be installed in 20" - 36" Racks				
Monitor Hinge	Heavy-duty Torque hinges to 60 lbs				
Color	Black Powder coated with light texture (Custom colors available)				
Weight (lbs)	18/27				
Shipping Box (DWD / DWI)	DWD 23 / DWI 27				





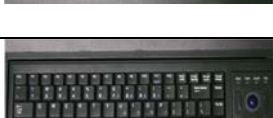







Mechanical Drawings

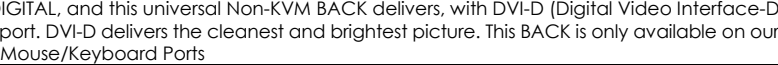

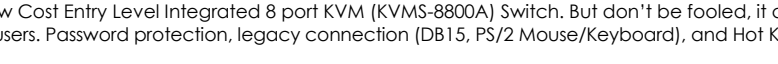

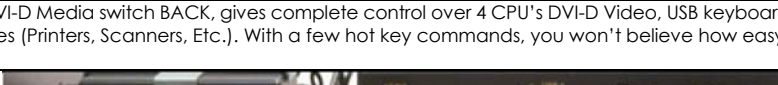

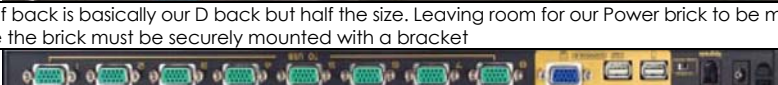
Keyboard Selections

Selection	Order Code	Supported Models	Description
	A	RD1U-CA20XX RD1U-C24XX RD1U-C27XX RD1U-C30XX RDKB Series	Cherry 83 key Keyboard with high quality 16 mm integrated trackball and two button pointing device. Featuring: Mechanical keys with gold cross point contacts for high-precision key action, individual key life expectancy approximately 20 million cycles and a MTBF of 134,000 hours. Multiple language support available. PS/2 Interface with Optional USB.
	B	RD1U-CA20XX RD1U-C24XX RDKB Series	IBM AT Compatible 104 key membrane Keyboard with high quality integrated Cirque Glidepad allows full mouse functionality. Individual key life expectancy approximately 5 million cycles. PS/2 Interface with Optional USB.
	D	RD1U-CA20XX RD1U-C24XX RDKB Series	Cherry 83 Key Keyboard with high quality Integrated Cirque Glidepad allows full mouse functionality. Featuring: Mechanical keys with gold cross point contacts for high-precision key action. Individual key life expectancy approximately 20 million cycles and a MTBF of 134,000 hours. Multiple language support available. PS/2 Interface with Optional USB.
	E	RD1U-CA20XX RD1U-C24XX RDKB Series	NEMA 4 with integrated Pressure Sensitive Pointing Device from Staco Switch. This keyboard was designed for rugged duty computer applications where clean environments must be maintained. This keyboard features a wipe able surface, allowing for easy removal of dust, dirt, chemicals or foreign matter. All keys are evenly backlit. PS/2 or USB Interface. Can be viewed while wearing Night Vision Goggles.
	F	RD1U-F27XX RD1U-F30XX RDKB Series	Sun Microsystems Type 5 Compatible , 101 to 105 Key (Depending on Language Variant) Keyboard with high quality 25 mm integrated trackball and three button pointing device. Featuring: Individual Key Life expectancy approximately 50 million cycles and a MTBF of 55,000 hours. USB Interface and Serial Variants to support new and legacy Sun Systems.
	G	RD1U-CA20XX RD1U-CA24XX RDKB Series	Keyboard: Cherry 83 Key Keyboard Featuring Mechanical Keys with Gold Cross point Contacts for high Precision action Individual life expectancy ~20 Million Cycles, MTBF of 134,000 hours. Multiple language support. Available PS/2 Interface, with optional USB. Mouse: Small enough to use right above the keyboard and tuck neatly away when you close the clamshell KVM Drawer - just 1" wide and 2-1/2" long. Smooth optical technology - point & click with ease, speed, and precision. Two buttons - left & right click. Works on most surfaces - no need for a mouse pad. High impact polycarbonate shell. Ultra-light 3ft. cord - durable yet flexible. Maintenance free with no ball or moving parts to clean. USB connector.
	H	RD1U-CA20XX RD1U-C24XX RD1U-C27XX RD1U-C30XX RDKB Series	This industrial 113 Key Keyboard with integrated Hula Point pointing device comes with 20 Function Keys, a 10-Key Number pad and is made of industrial silicone rubber. It has an operating temperature range of -40F to 194F (-40C to 90C) and a MTBF Greater than 10 Million Cycles. It can be ordered in MS Windows (PS/2 or USB) or SUN (USB only) Configurations.
	I	RD1U-CA20XX RD1U-C24XX RD1U-C27XX RD1U-C30XX RDKB Series	(SP6G) This touchpad keyboard has an enhanced slim design, which works with any IBM PS/2 compatible computer. Utilizing the latest in rubber mechanical key switch technology. Built-in touchpad with super sensing technology for precise tracking, 3 standard mouse buttons, excellent tactile key stroke. High quality rubber membrane key switches. PS/2 and (USB Iu Order Code) Interface. Work with KVM switches, 1,000,000 life cycles Compatible OS: Win 98SE / 2000/ME/XP FCC, CE, ESD and BSMI certification
	J	RD1U-CA20XX RD1U-C24XX RD1U-C27XX RD1U-C30XX RDKB Series	(SP7T) This trackball-keyboard has an enhanced slim design, which works with any IBM PS/2 compatible computer. Utilizing the latest in rubber mechanical key switch technology. Built-in ø16mm optical trackball 2 standard mouse buttons, excellent tactile key stroke. High quality rubber membrane key switches, PS/2 and (USB Ju Order Code) Interface, Work with KVM switches, 1,000,000 life cycles Compatible OS: Win 98 SE/2000/ME/XP FCC, CE, ESD and BSMI certification.
	L	RD1U-CA2017.KDMac RD1U-CA2017.KGMac	A stylish Apple® computer deserves an equally stylish keyboard. This SlimType Keyboard for Apple Computers takes its inspiration from Apple's distinctive sleek lines and contemporary design. That low-profile form is then packed with performance and convenience functions. Low-travel, scissor-switch technology delivers a crisp, responsive touch for faster typing. And multimedia hot keys provide intuitive, one-button control of audio and video playback.
	L	RD1U-CA20XX RD1U-C24XX RDKB Series	Staco Systems newest NVIS Green B compatible keyboard, series K7088, was designed with LED backlighting that is compatible with night vision goggles. This keyboard has a filter which reduces interference of light between the night vision goggles and the illuminated keys. The K7088 is perfect for military, aerospace, law enforcement, and emergency medical operations that require effective visual enhancement at night. Specific applications include helicopters, tanks, submarines, and any other custom platform. Staco System's NVIS keyboards are MIL-STD 461E for EMC compliant. They are also NEMA 4x sealed for protection against water and dust/sand. "The advantage of the K7088 keyboard is NVIS compatibility that can work with any military and commercial aircrafts. The K7088 comes with a built-in touchpad pointer control with left and right mouse buttons. It includes a USB or PS2 connectivity, and a one-touch emergency key.
	M	RD1U-CA20XX RD1U-C24XX RDKB Series	KML-119 is the second Sun Microsystems keyboard we offer for the RD1U series. It features a 119 key US or UK layout (Specific language variants available upon request) and a high quality touch pad. Individual Key Life expectancy approximately 50 million cycles. Key travel 3mm. Typical operating force 50gm.

KVM Selections

Order Code	Description
A – Back	
B – Back	<p>This Universal Non-KVM BACK is our base model and comes with one (1) aRGB video port, and two (2) PS/2 (Optional USB) mouse/keyboard ports.</p> 
C – Back	<p>This Keyboard Video Mouse Switch (KVMS-08A) BACK is our High End 8 port unit with High Density connector containing aRGB Video, Mouse and Keyboard signals. With this unit you can connect the Console Drawer to 8 CPU's directly. You can also Cascade up to 504 CPU's using the dedicated cascading port. (You can daisy chain up to 31 stand alone 16 port KVMS-16A to this console.) With the Programmable Asics Chipset and upgrade port. Obsolescence is greatly reduced</p>
D – Back	 <p>This BACK has an integrated KVMS-16A giving you all of the features of the "B" BACK (integrated KVMS-08A) Plus 8 more ports! This brings the total up to 16 CPU ports controlled directly and up to 512 total, when you cascade up to 31 stand alone KVMS-16A switches</p>
E – Back	<p>The D stands for DIGITAL, and this universal Non-KVM BACK delivers, with DVI-D (Digital Video Interface-Digital), aRGB Video, and PS/2 keyboard/mouse port. DVI-D delivers the cleanest and brightest picture. This BACK is only available on our RD1U-C24XX Series and can be ordered with optional USB Mouse/Keyboard Ports</p> 
F – Back	<p>This Back is our Low Cost Entry Level Integrated 8 port KVM (KVMS-8800A) Switch. But don't be fooled, it delivers plenty of power with an OSD menu for up to 4 users. Password protection, legacy connection (DB15, PS/2 Mouse/Keyboard), and Hot Key functionality, all at an affordable price.</p> 
G – Back	<p>This Back is our Vista Rose Integrated 8 port KVM Switch. With optional OSD menu. Password protection, legacy connection (DB15, PS/2 Mouse/Keyboard), and Hot Key functionality, all at an affordable price.</p> 
H – Back	<p>First generation DVI-D Media switch BACK, gives complete control over 4 CPU's DVI-D Video, USB keyboard/mouse, speaker, microphone, and even 2 USB devices (Printers, Scanners, Etc.). With a few hot key commands, you won't believe how easy it is to jump from one multi-media PC to the next.</p> 
I – Back	<p>Half Back: Our Half back is basically our D back but half the size. Leaving room for our Power brick to be mounted to the left. Good for Transit Case applications where the brick must be securely mounted with a bracket</p> 
J – Back	<p>KVMS-08U. Control 8 Pure USB computers with one USB K/B, one USB mouse, and one VGA monitor. Can Daisy Chain to Control up to 512 PC's. Supports multimedia USB keyboards (PC, Mac and Sun). Firmware upgrades to all the chained KVM switches at the same time via the daisy chain cable. OSD is mouse driven for quick and convenient navigation of the menu. OSD selection for OS and keyboard language. Security - administrator / user password authorization for enhanced security protection (PSP). Broadcast Mode: Operations simultaneously performed on all selected computers, software installation and upgrading, system wide shutdown. etc, OS Compatibility: WIN98, WIN ME, WIN 2K, WIN 2003, WIN XP, LINUX, Mac OS 8.6/9/10 and SUN Solaris 8/9.</p> 
K – Back	<p>IS Hybrid Back</p> 
L – Back	<p>We Combined the best of both worlds with the combination of our I - Back and S - Back to produce the IS Hybrid Back, a back with all the essential features. (See the I & S Back features for more details).</p> 
M – Back	<p>KVMS-16U. Control 16 Pure USB computers with all the same features of the I - Back KVMS-8U</p> 
N – Back	<p>KVMS-RGBA4 - Our new 4-port KVM and Peripheral Sharing Switch brings extra value to conventional KVM switches by offering USB peripheral sharing capabilities, audio and microphone support, and multi-platform support for Mac, Sun, USB and PS/2. Up to 127 different USB devices can be daisy chained from this KVM switch. Sharing speakers and a microphone also offers extra value and convenience for the users. USB and KVM technology together makes cross-platform management easy. A single USB console can control PCs, Macs, or even Sun workstations, and share peripherals and audio devices between the computers. Any USB-enabled computers, using any USB-compatible operating system, can benefit from the efficiency, expense reduction and convenience of this switch.</p> 

Order Code	Description
L – Back	
	<p>KVMS-08C Switches are control units that allow access to up to 8 computers from a single KVM (keyboard, monitor, and mouse) console. They feature RJ-45 connectors and Cat 5 cable to link to the computers. Combined with Auto Signal Compensation (ASC) signals can travel up to 40 meters and still maintain high video resolution. Utilizing PS/2 and USB KVM Adapter Cables for the final linkup. They also permit any combination of PCs, Macs, Sun computers, and serial devices to coexist on the installation.</p>
M – Back	
	<p>KVMS-16C Switches are control units that allow access to up to 16 computers from a single KVM (keyboard, monitor, and mouse) console. They feature RJ-45 connectors and Cat 5 cable to link to the computers. Combined with Auto Signal Compensation (ASC) signals can travel up to 40 meters and still maintain high video resolution. Utilizing PS/2 and USB KVM Adapter Cables for the final linkup. They also permit any combination of PCs, Macs, Sun computers, and serial devices to coexist on the installation.</p>
S – Back	
	<p>HD/SD-SDI Back: High Definition/ Standard Definition – Serial Digital Interface. Integrated into any of our 1U drawers will give you all the SDI video formats including NTSC, PAL, 720p, 1080p and 1080i. On screen Display along with remote will help you navigate between the Input Formats. DVI-D (via DVI-I connector), Analog RGB (via DVI-I connector)</p>
V – Back	
	<p>Our V BACK has all the Video and Input Ports you will need: aRGB, DVI-D, S Video, CSV with BNC Post, and PS/2 (option USB) keyboard / mouse. You can toggle between all of the video inputs sources right from the monitors OSD keypad.</p>