

1U Rack mount 17" TFT SAMSUNG LCD Monitor Drawer

Model: NP117

Features:

- Unique mechanical design to maximize rack mountable space
- Unique monitor flip up design allows viewing through closed glass door of cabinet
- Adjustable mounting brackets from 15.4" to 29.2"
- Slide rails have two fixed positions to prevent movement of the keyboard
- Built-in on screen display controlled by integral membrane switches



- **SAMSUNG Industrial LCD Panel**
- **Optional Video Input-S-Video and Composite Video Input --Supported PAL & NTSC**
- **Optional -48V DC Input Supply**
- **Optional 3M Touch Screens**
- Front-access lock of security
- Standard D-sub 15-pin VGA input connector
- Supplied with 12V 5A remote power adapter
- All mounting hardware included

Specification

Monitor

Panel:	17" LCD panel
Display type:	TFT / LCD active matrix color
Resolutions:	1028 x 1024
Response time:	Tr=5ms/ Tf=20ms
Contrast ratio:	350 : 1 typical
Brightness:	250 cd/m2 typical
Pixel pitch:	0.264mm (H) x 0.264mm (W)
Panel color:	16.7 million display colors
Viewing angle:	150° (Horiz.)/ 125° (Vert.)
Storage temp.	-20° C to 60° C
Operating temp.	0° C to 50° C
MTBF	20,000 hours

Power supply

Remote adapter:	110V - 220V AC Input , 12V 5A Output
Adapter Size:	4.3"(L) x 2.4" (W) x 1.2"(H) (108x61x30mm)
Cable length from mains plug to adapter:	6ft (182cm)
Cable length from adapter to unit:	6ft (180cm)
Safety approval:	UL, CE
Mains plug options available	

Product dimension--- 17.3"(W) x 1.75"(H) x 21.7"(D)
(43.9 x 4.45 x 55 cm)

Packing dimension--- 28.96"(L) x 22.66"(W) x 7"(H)
(73.5 x 57.5 x 18cm)

Weight

Model No	Net / Gross weight
NP117	25.3lbs / 31.9 lbs (11.5kg / 14.5kg)

Construction

1. Class A active matrix TFT LCD panel
2. Analog-to-digital signal converter board
3. Rear metal case
4. Inverter
5. Adjustable mounting bracket
6. Ball bearing telescopic slides with stopper
7. Security lock
8. Panel button controls

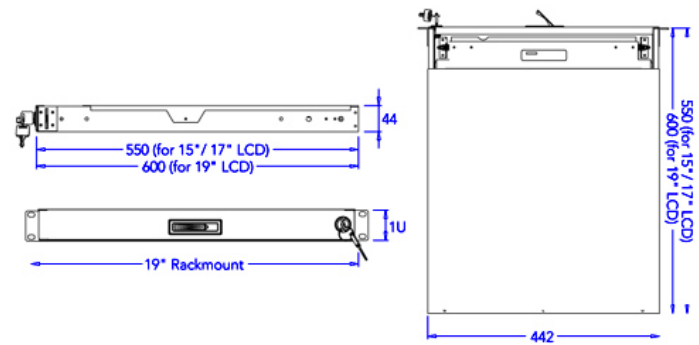

Unit : mm

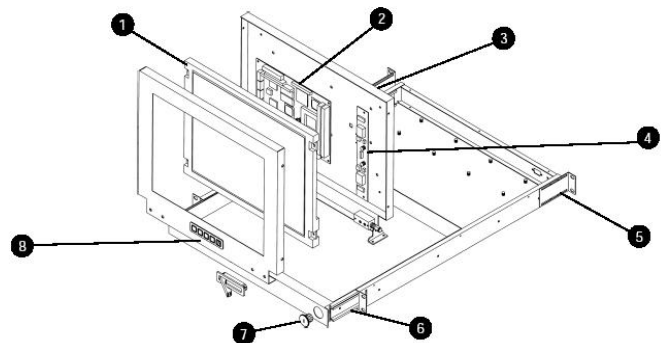

- Adjustable mounting bracket from 390 to 740mm (front to rear 19" mounts)
- Suitable for 650 to 1000mm deep 19" cabinet

