

# iPC1210AT / iPC1500AT

## Quick Installation Guide



**Copyright © i-Tech Company LLC. All Rights Reserved.**

No part of this manual, including the products and software described in it, may be reproduced, transmitted, transcribed, stored in a retrieval system, or translated into any language in any form or by any means, except documentation kept by the purchaser for backup purposes, without the express written permission of i-Tech Company LLC.

Products and corporate names mentioned in this manual may or may not be registered trademarks or copyrights of their respective companies, and are used for identification purposes only. All trademarks are the property of their respective owners.

Every effort has been made to ensure that the contents of this manual are correct and up to date. However, the manufacturer makes no guarantee regarding the accuracy of its contents, and reserves the right to make changes without prior notice.

# Components

## Front side

iPC1500AT

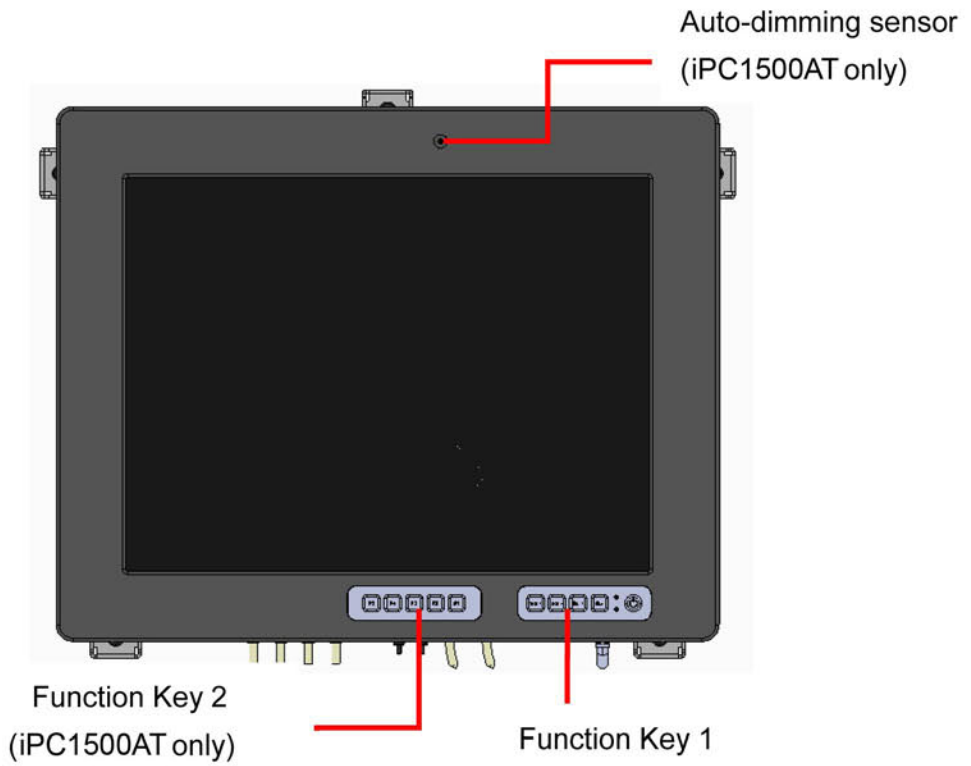

iPC1210AT

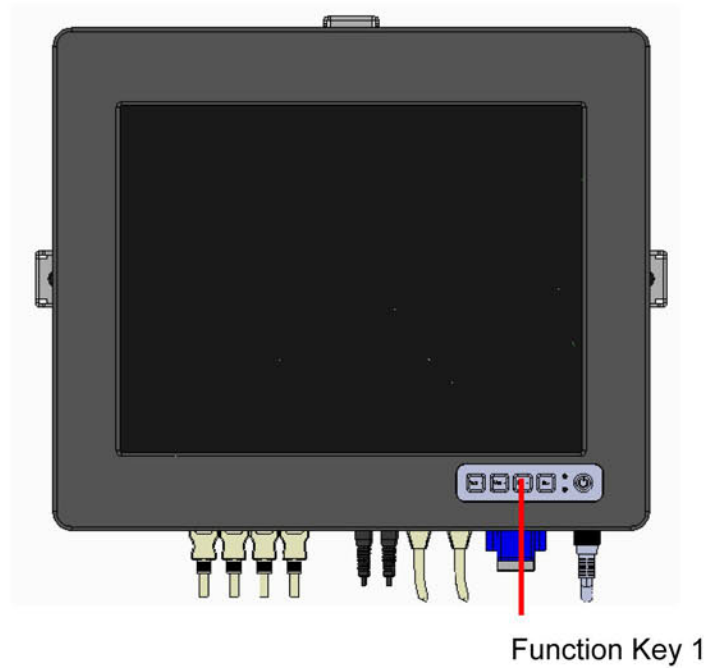

## Function key

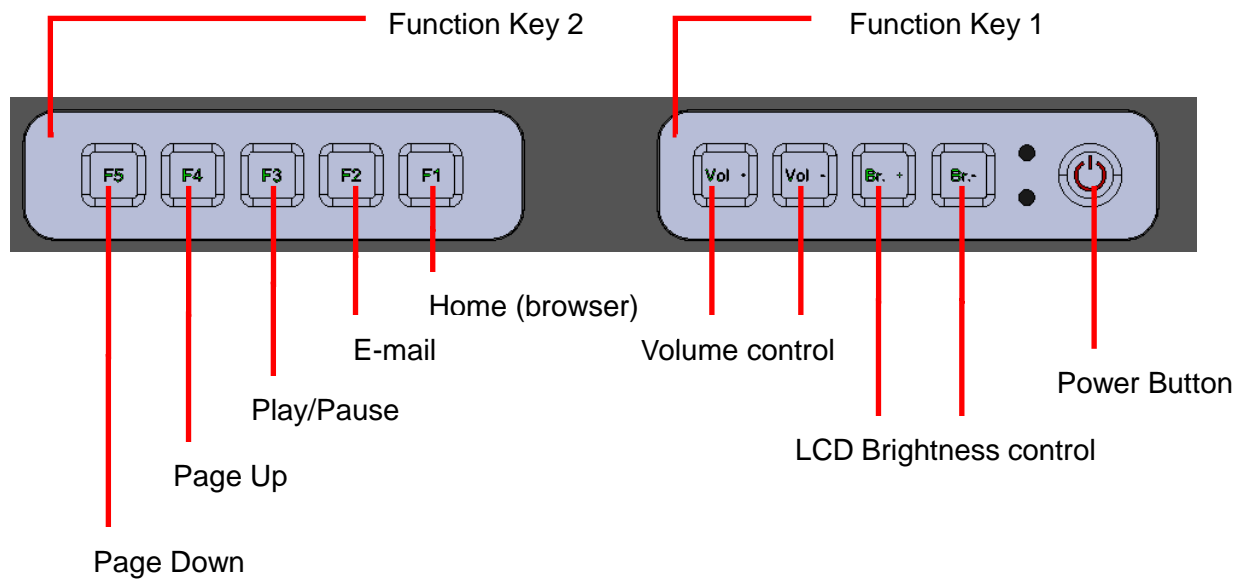

## IO side

Refer to the diagram below to identify the components on this side of the system.

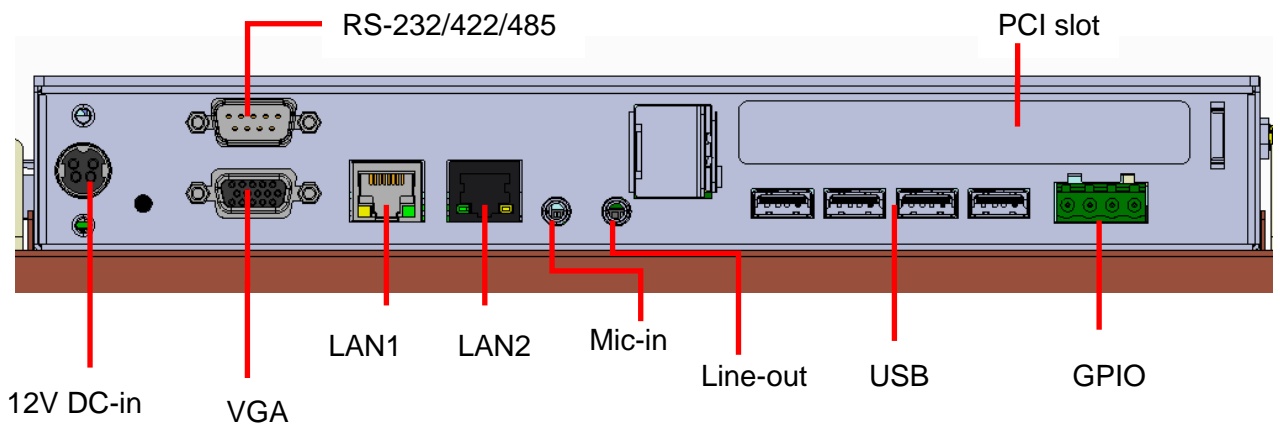

## Top View

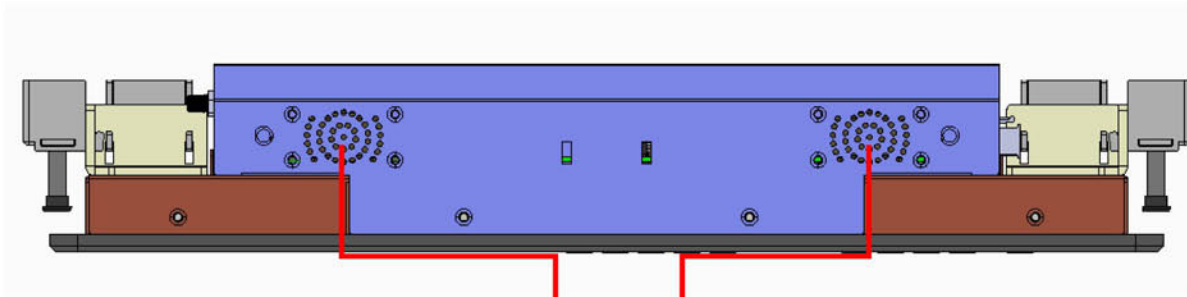

Speaker  
(iPC1500AT only)

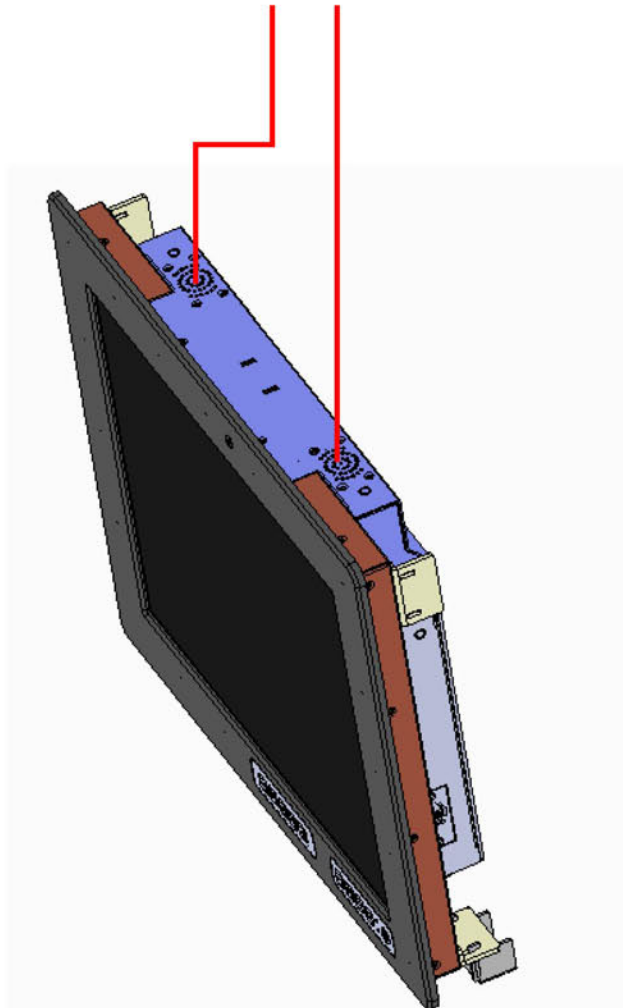

# Installation

## Installing Panel Mount

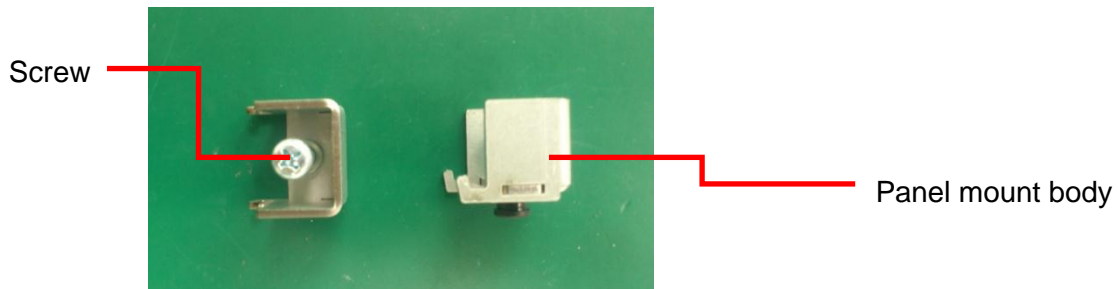

1. To assembly screw and panel mount body and put on the rubber cap at screw bottom as above picture.

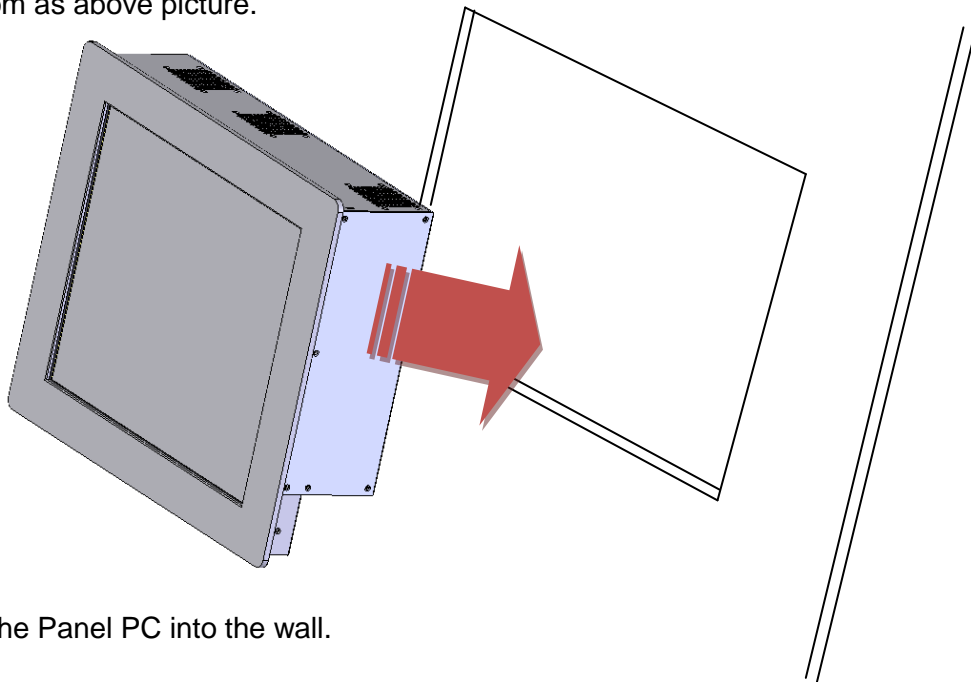

2. Put the Panel PC into the wall.

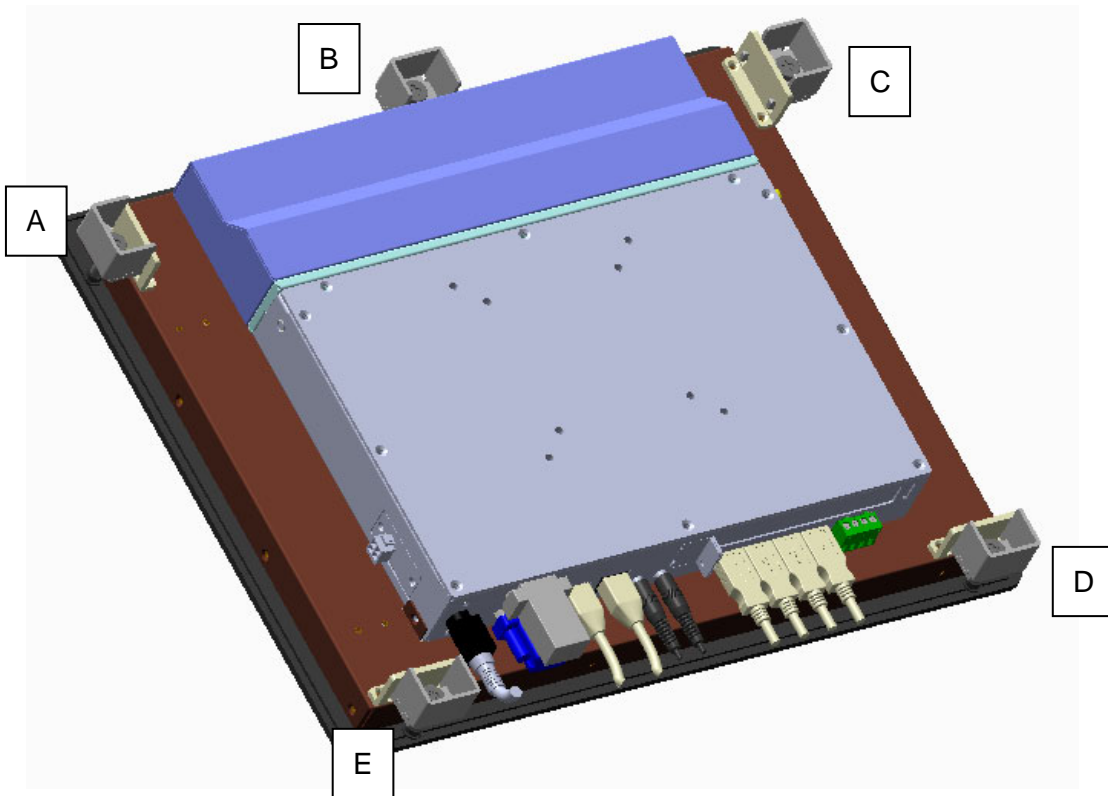

3. Put the panel mount from A to E

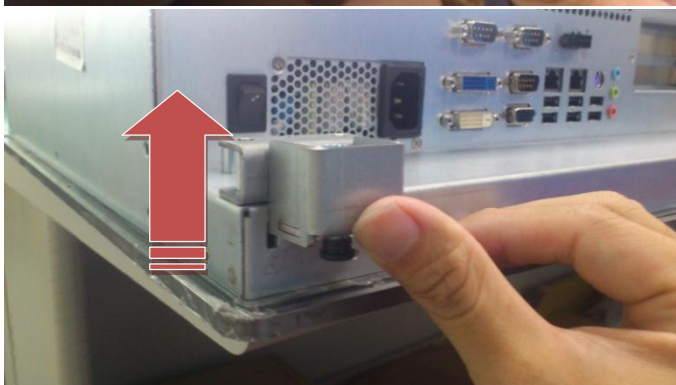

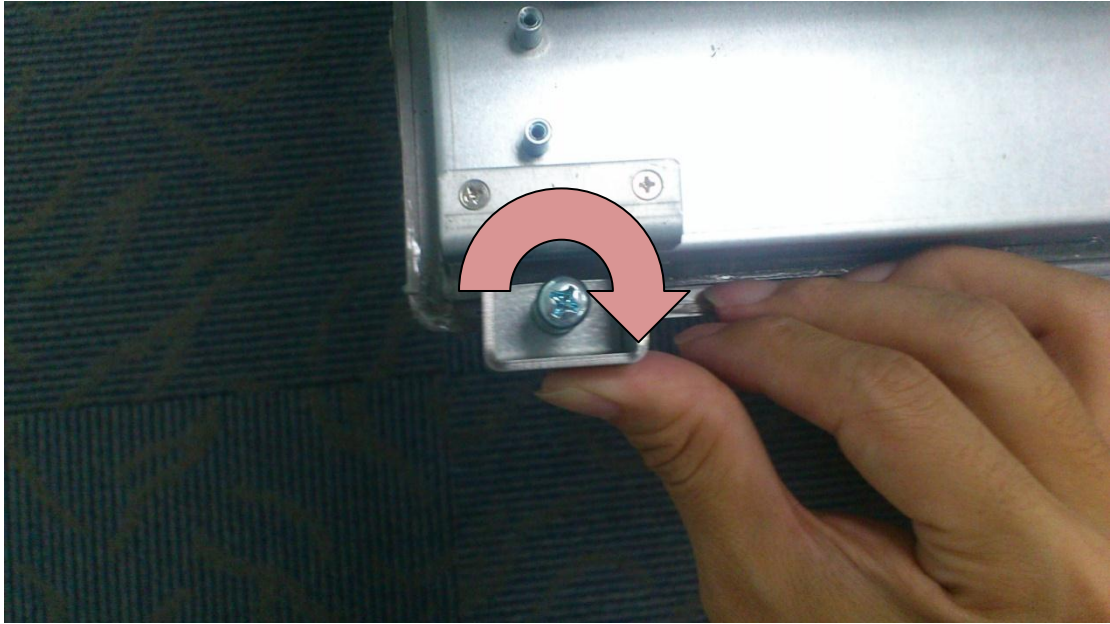

4. Lock the each screw of the panel mount.



## Installing VESA mount

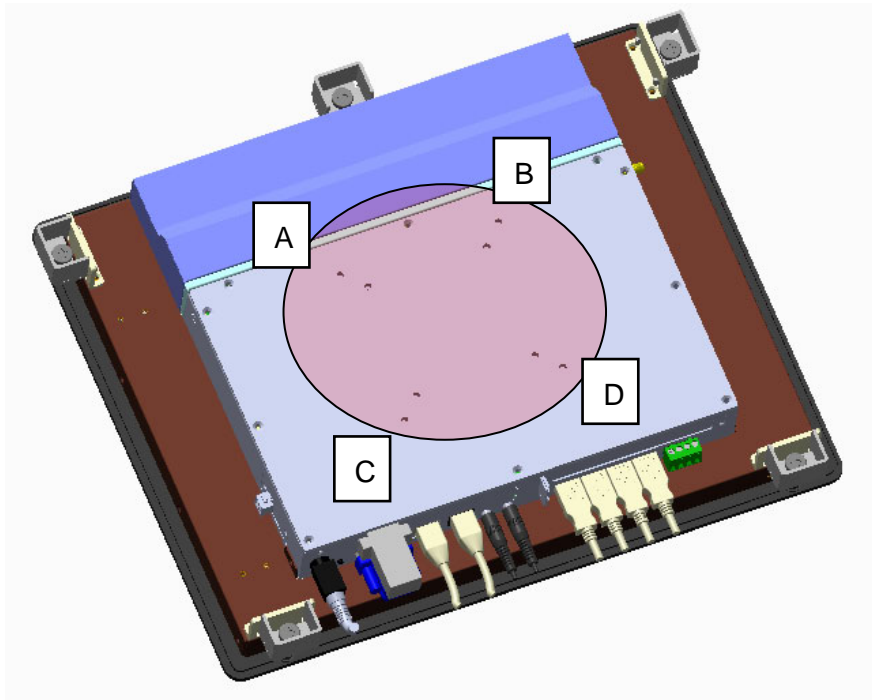

1. VESA mount of iBASE Panel PC is compatible with VESA stand 75x75 and 100x100
2. Put your VESA mount Kit on the Red Area.
3. Lock the screws from A to D.

## Installing PCI module

1. Unlock and remove screws from point 1 to point 10
2. Remove the back cover (a Yellow part) from PPC controller.

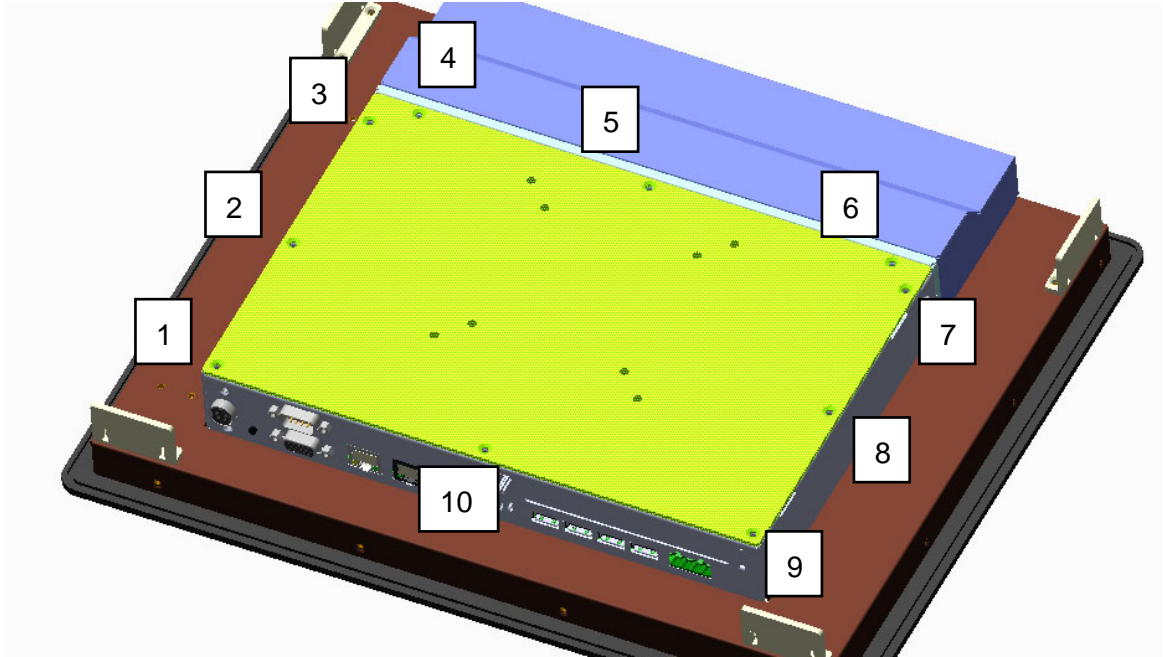

3. Unlock and Remove a screw from PCI slot cover.
4. Remove PCI cover and PCI cover bracket from inside.

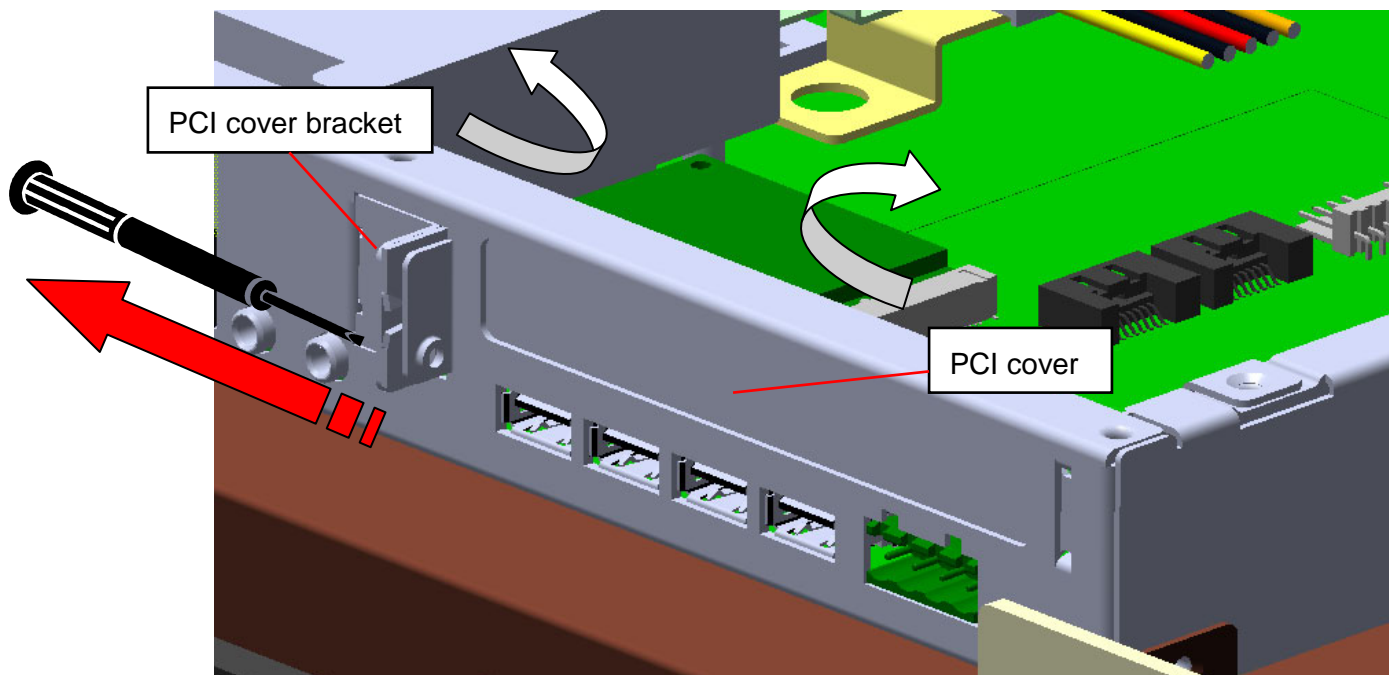

5. Install your PCI add-on card. (red circle are PCI slots)

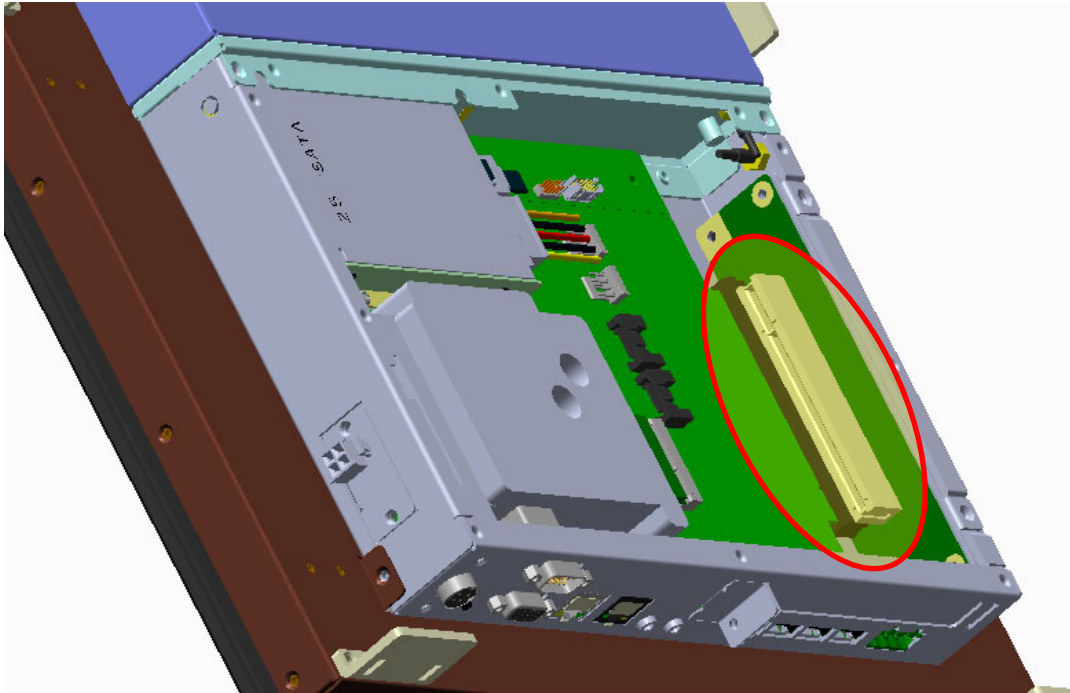

6. Put on the PCI cover bracket and lock the screw.

7. Put on the back cover and lock screws to finish the PCI add-on card installation.

## Disassembly and Assembly control box and display module

### Disassembly

1. Unlock and remove screws from point A and B

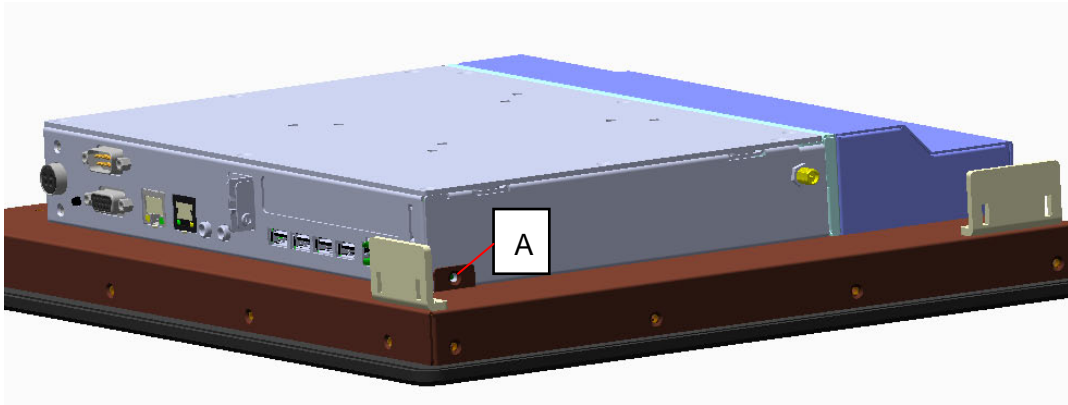

2. To slide the control box to the bottom and pull to up to remove the control box.

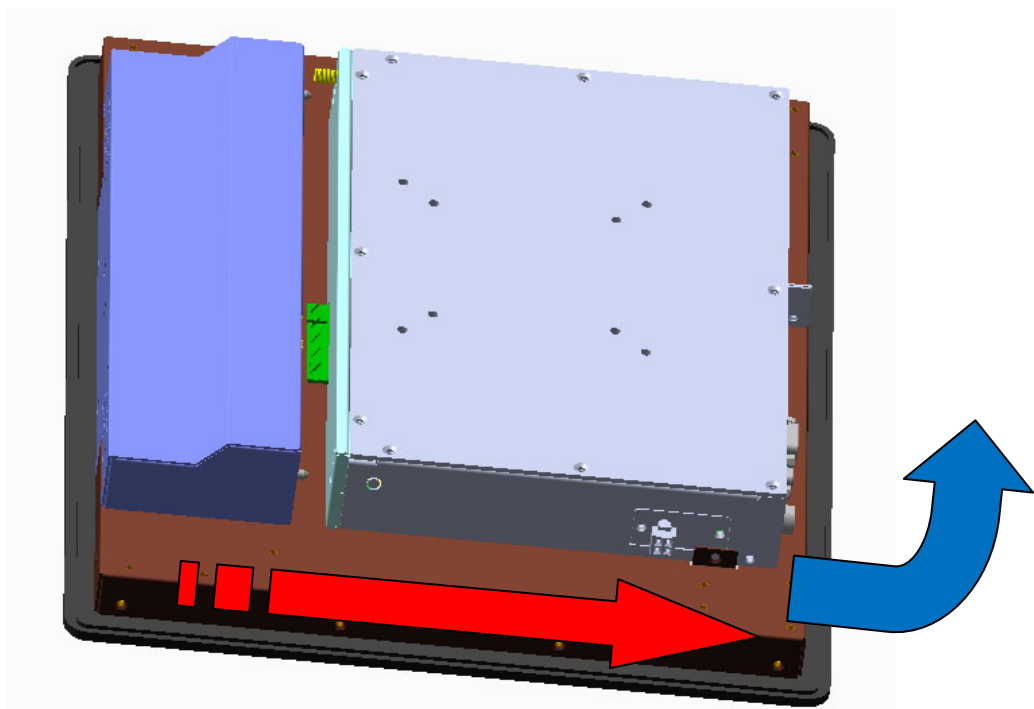

## Assembly

1. To locate the adjusting pin with mounting hole of control box.

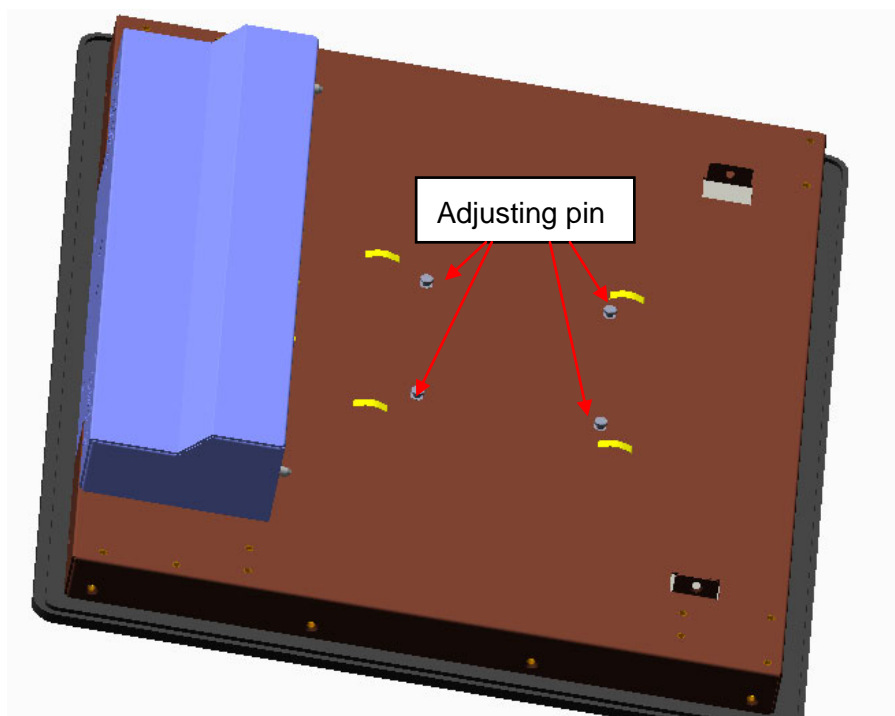
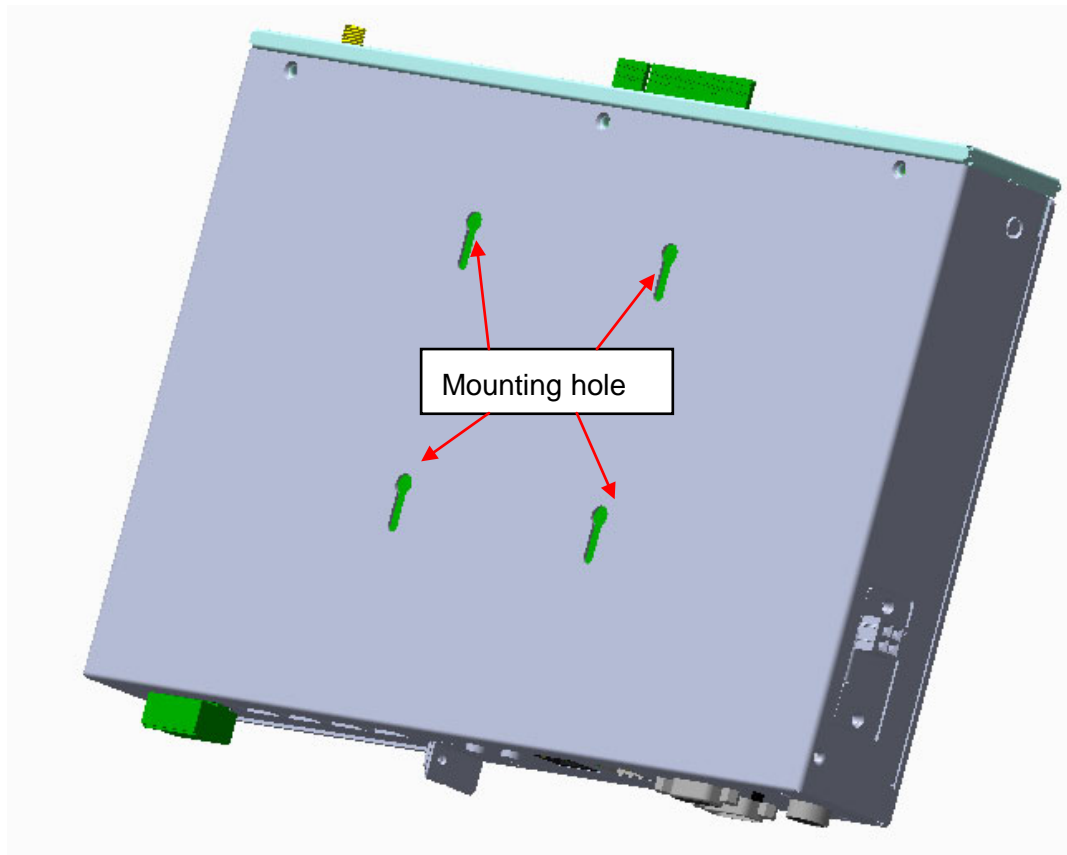

2. To push the control box to the top..

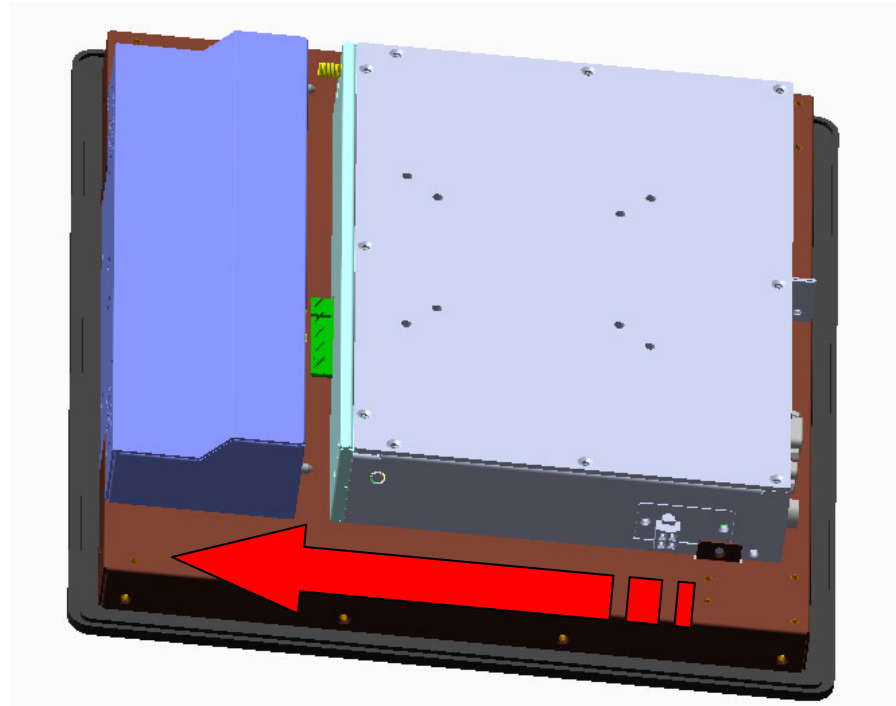

3. To lock point A and B screws.

