

KENDALL HOWARD

Corner Unit Assembly and Maintenance Manual

Workbenches LAN Stations And Accessories



Distributed by : i-Tech Company LLC

TOLL FREE: (888) 483-2418 • EMAIL: info@iTechLCD.com • WEB: www.iTechLCD.com

Your New Performance Workstation

Congratulations on your new Kendall Howard Performance LAN Station Workbench. This manual will step you through the assembly process. If you have trouble, please feel free to call our customer service department from 8:30 AM to 5:30 PM CST.

Step 1. Inventory

Please be sure that you unpack the crate completely and take a complete inventory of what you have received. This will save you much time if parts are missing and you have to stop in the middle of the build process. We take every precaution to ensure that you do receive all parts required; however accidents do happen in shipping that may cause the loss of a key part. If you suspect that you are missing parts, please contact our customer service department immediately at 651-340-1400. You will need to have your order confirmation number before you call.

PART	QTY	PART	QTY
Levelers	6	2 Work Surface Brackets	2
Table Sides (1 left, 1 right)	2	3/4" Round Plastic End Cap	18
Cross Bars	4	1 1/2" Square Plastic End Cap	8
Upper Shelf Supports	8	1 1/2" x 2" Rectangle End Cap	4
Upper Shelf Channels	4	Channel Nut	16
Upper Shelf	2	1 1/2 Hex Drive Bolt	22
Work Surface	1	2 1/2" Hex Drive Bolt	8
Cable Support (Left, Right, Center)	3	T-Handle Hex Wrench	1
Back C-Frame (1 left, 1 right)	2	Cross Head Screw	14

Step 2. Assemble the Work Surface

Place the work surface on a clean surface and install the front and rear table supports with the provided cross head screws. Leave screws slightly loose.

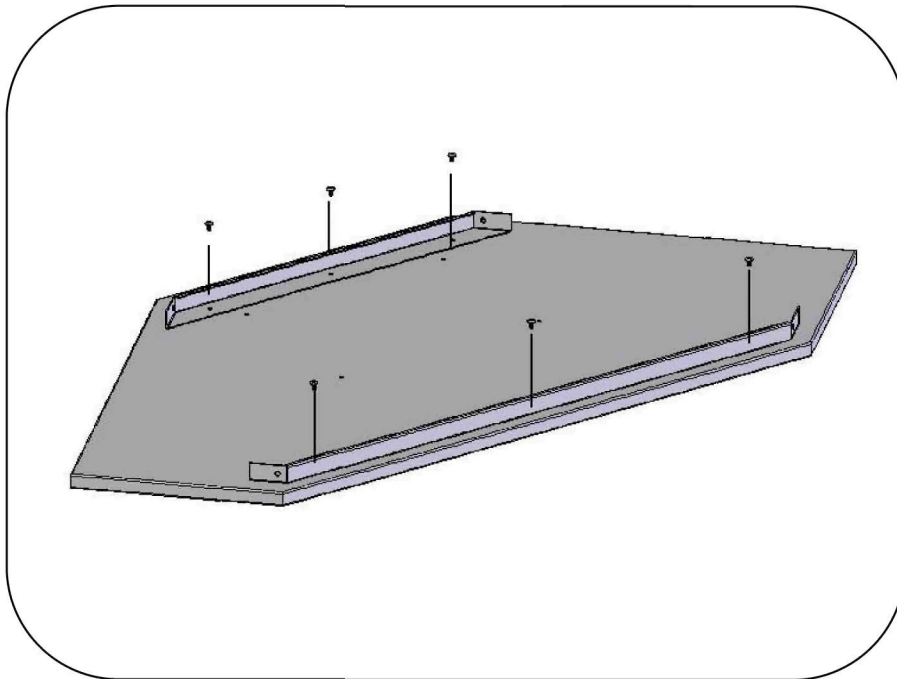

Step 3. Assemble the Side Frames

Attach the left frame to the left sub frame with (2) 3/8X1.5 cap head bolts and fully tighten bolts. Next screw in the 6 levelers into the receiving holes located at the bottom of the frame sets

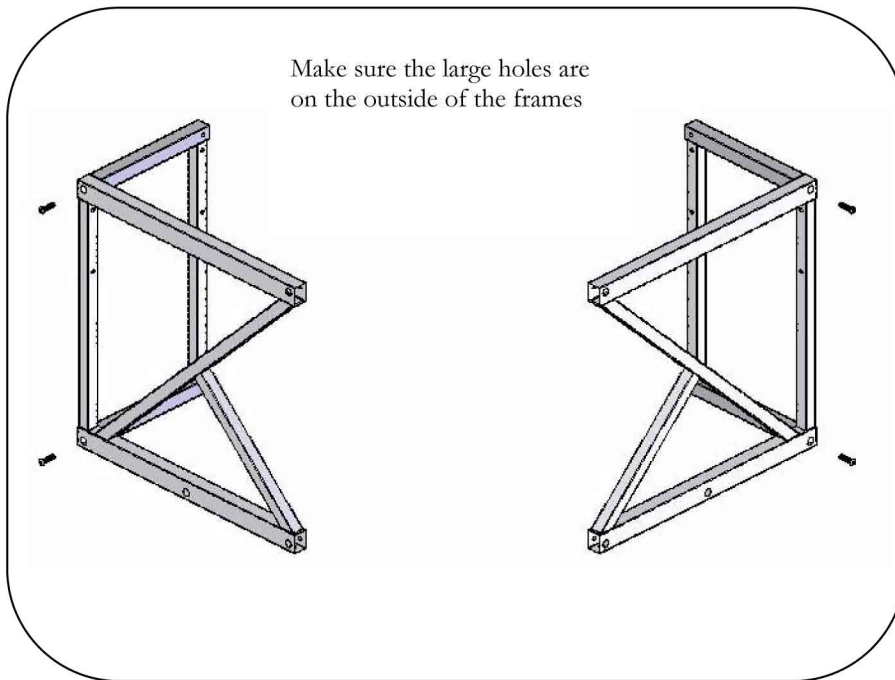

Step 4. Assemble the Bottom Table

With the table top laying down with the bolt holes and sub frame up, attach the left and right leg assemblies using the (4) 3/8 X 1.5" and 4 channel nuts.

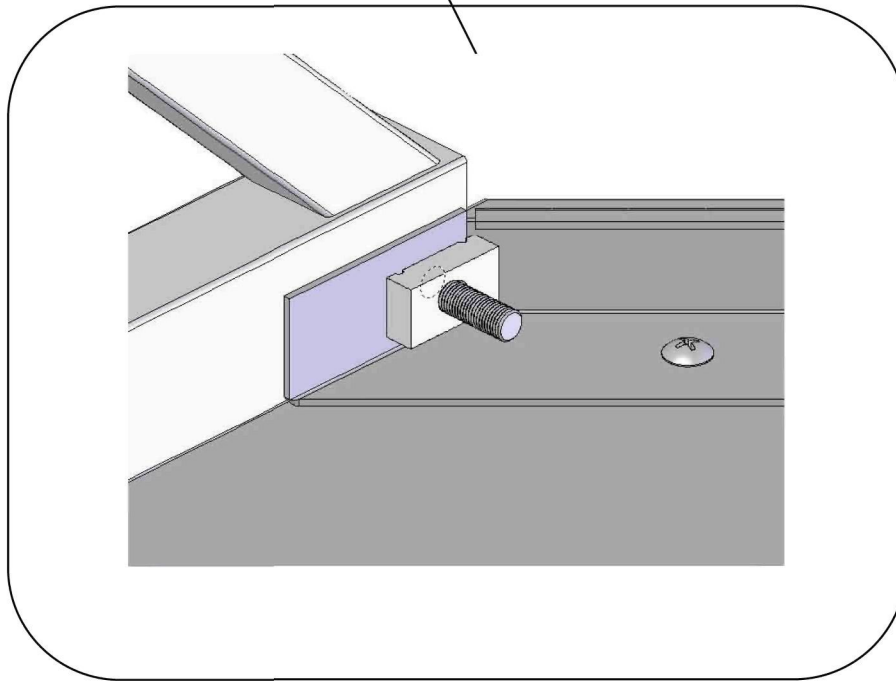
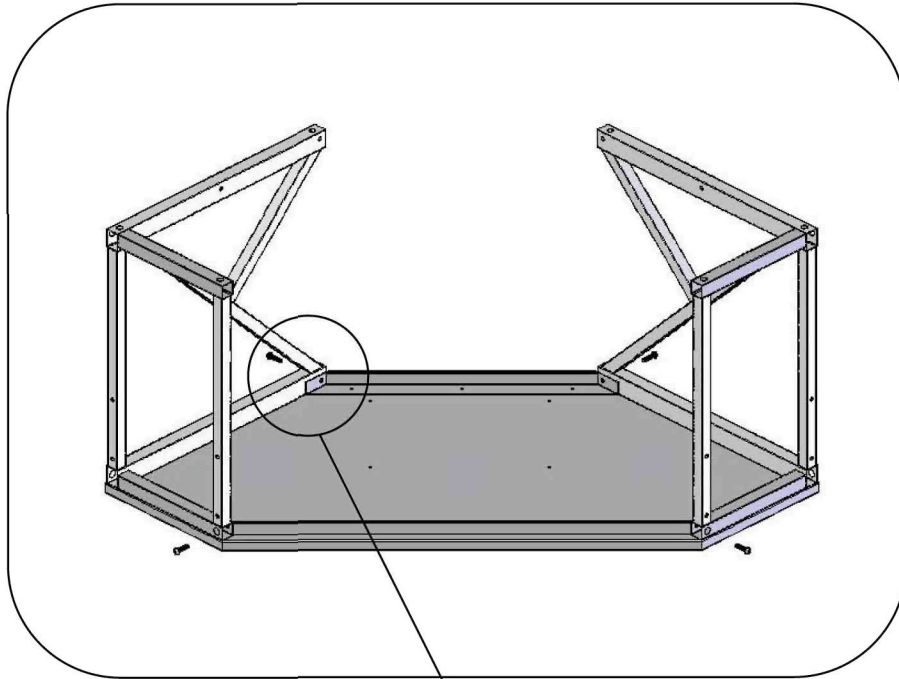

Step 5. Assemble the Back Plates and Shelf Supports

With the table in the upright position, add the left and then right back plates using only out side bolts. Once both left and right back plates have been attached using 4 (2 each) 3/8 X 2 1/2" bolts you may then add the center back plate. Next, add 8 channel nuts, one to each bolt. Leave about 1/4" between the nut and the frame. **DO NOT FULLY TIGHTEN AT THIS TIME.** Leave nuts with the long side pointing up.

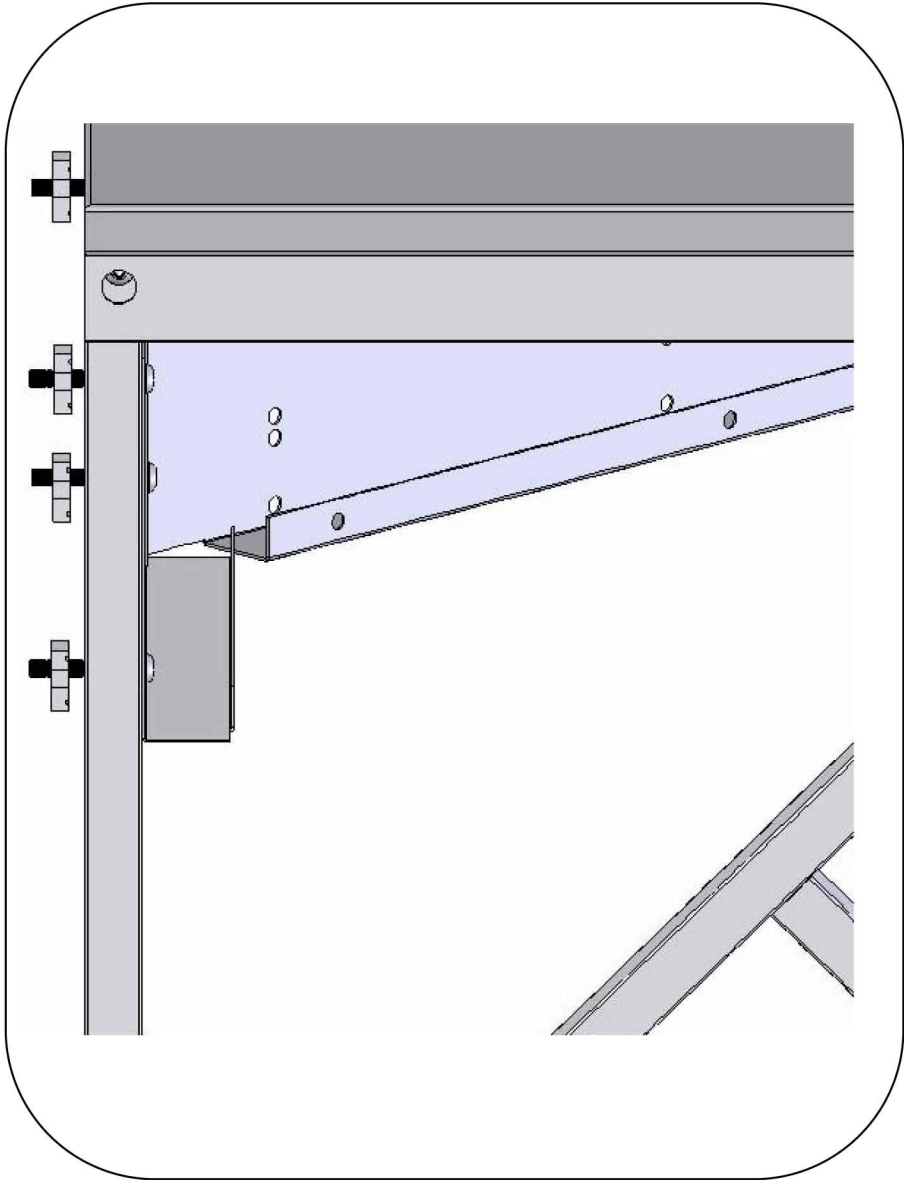

Step 6. Add the upper shelf supports

Place the shelf channels over the channel nuts on the back of the table. Tighten each nut slowly until the nut turns into the channel.

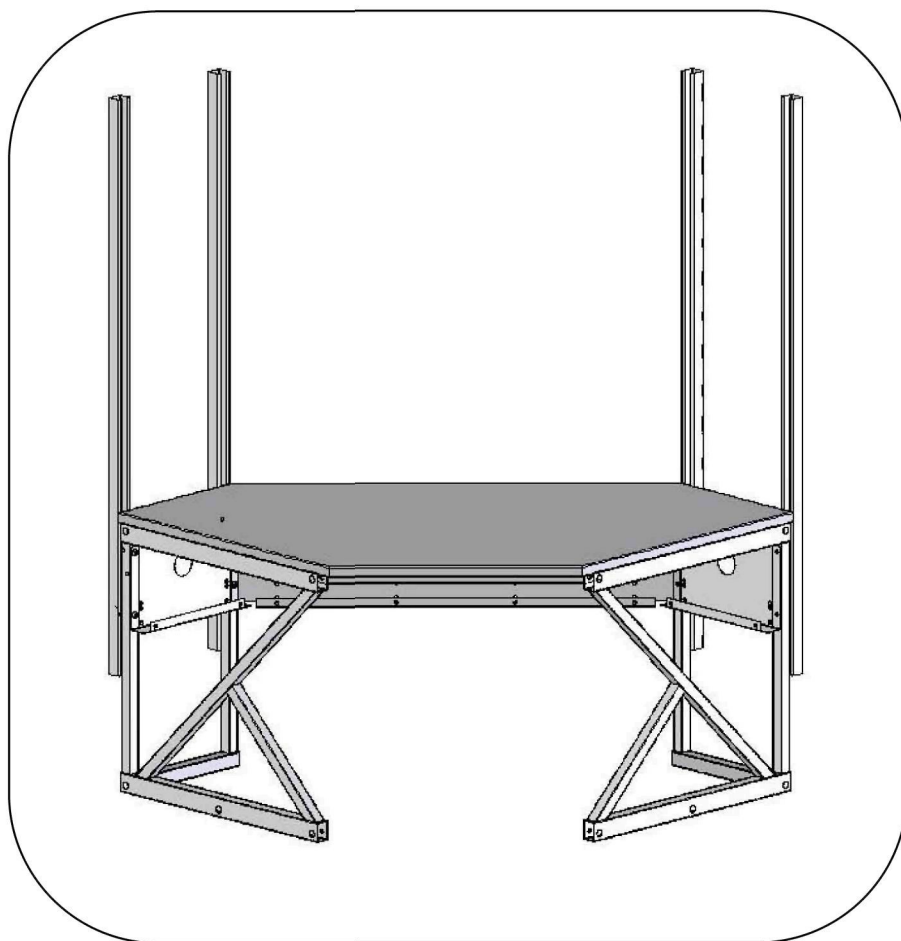

Step 7. Assemble the Shelf Arms

Assemble 4 sets of shelf support arms using the 3/8 X 1.5 bolts. DO NOT FULLY TIGHTEN AT THIS TIME.

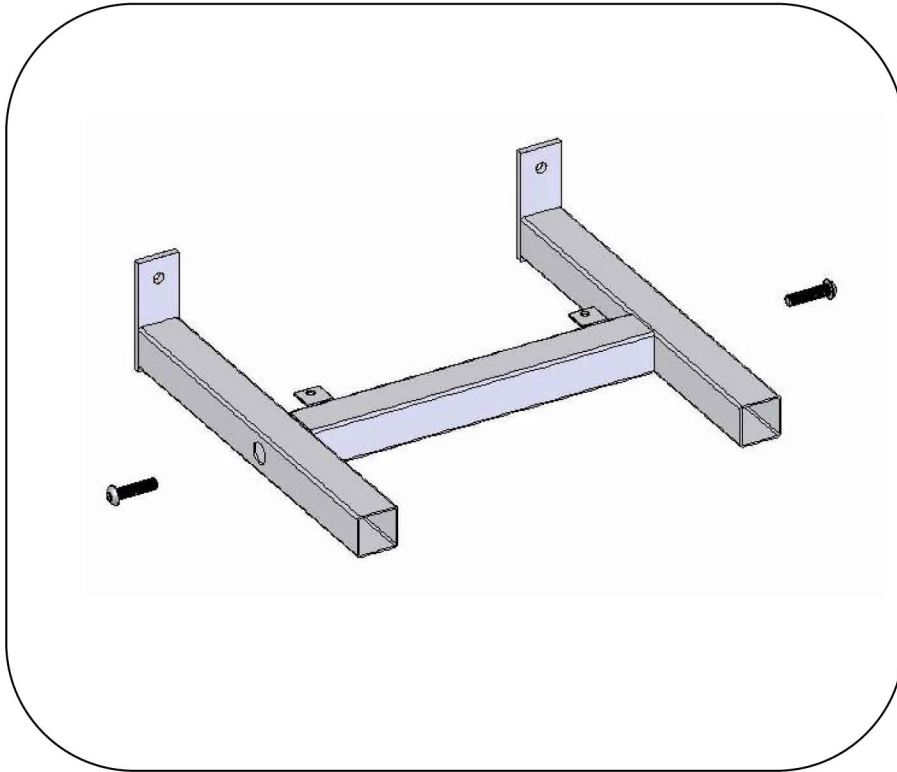

Step 8. Assemble the upper shelves

With the upper shelves upside down, add the shelf support arms using the cross head screws provided.

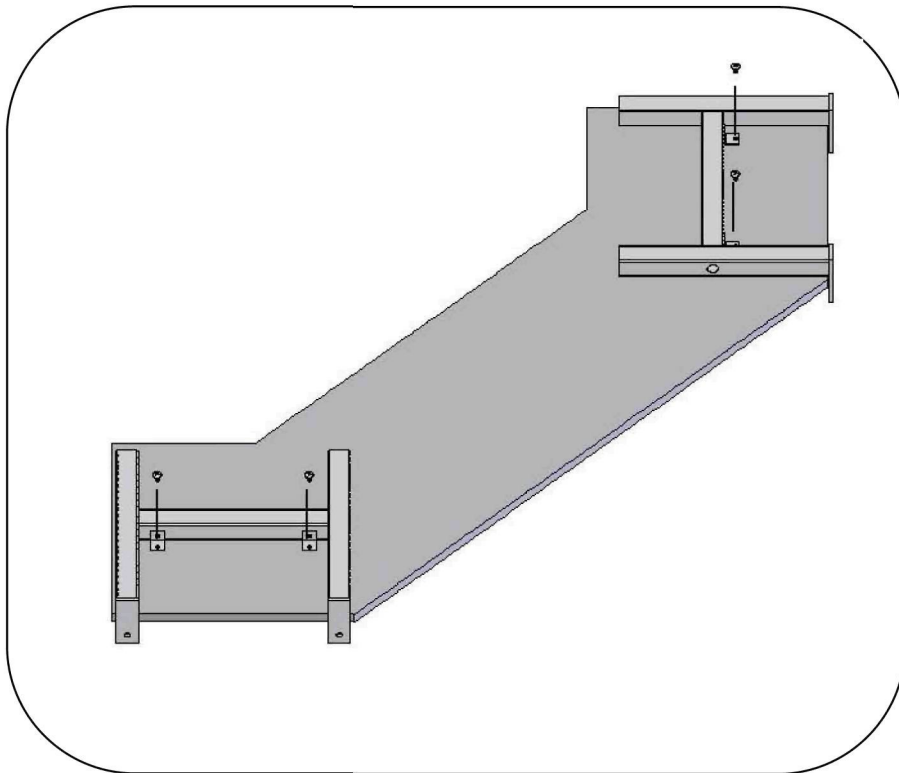

Step 9. Attach the Upper Shelves

For this step you will need at least one helper. Add a 3/8 X 1.5" bolt to each shelf arm hole. Next, add a channel nut to each bolt leaving at least 1/4" of space between the nut and the shelf arm. Carefully lift the shelf placing the nut inside the channel. With the provided T-Handle wrench, tighten the bolts until the nut turns into place.

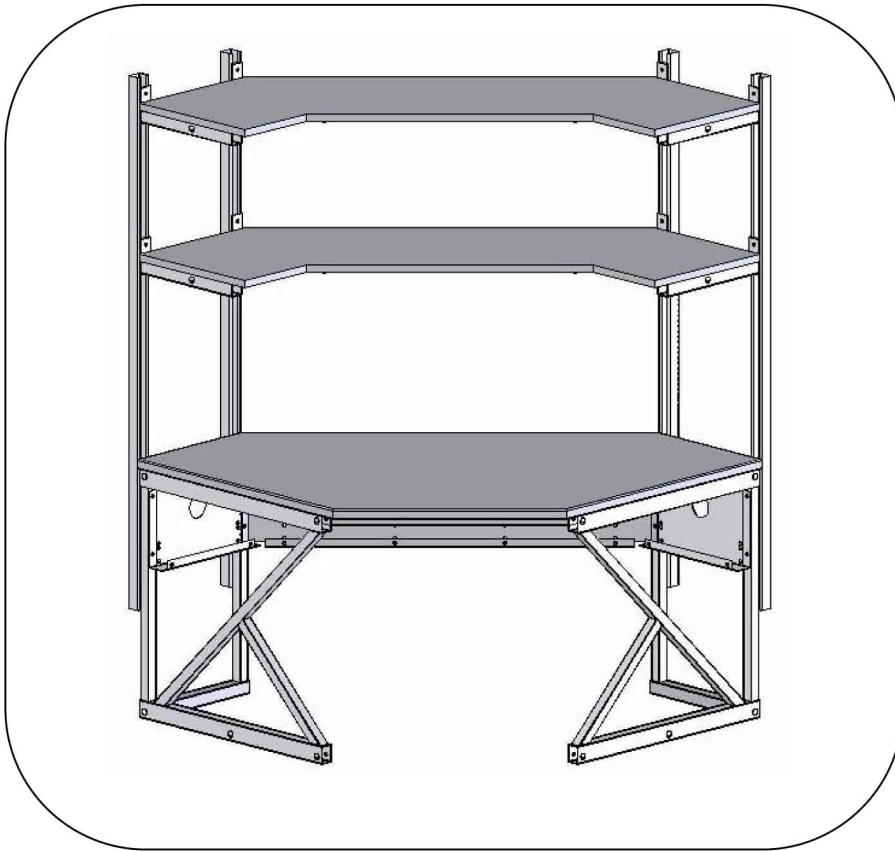

Step 10. Add the Plastic End Caps

Insert the plastic end $\frac{3}{4}$ " round caps into the left and right side frames as well as the upper shelf supports.

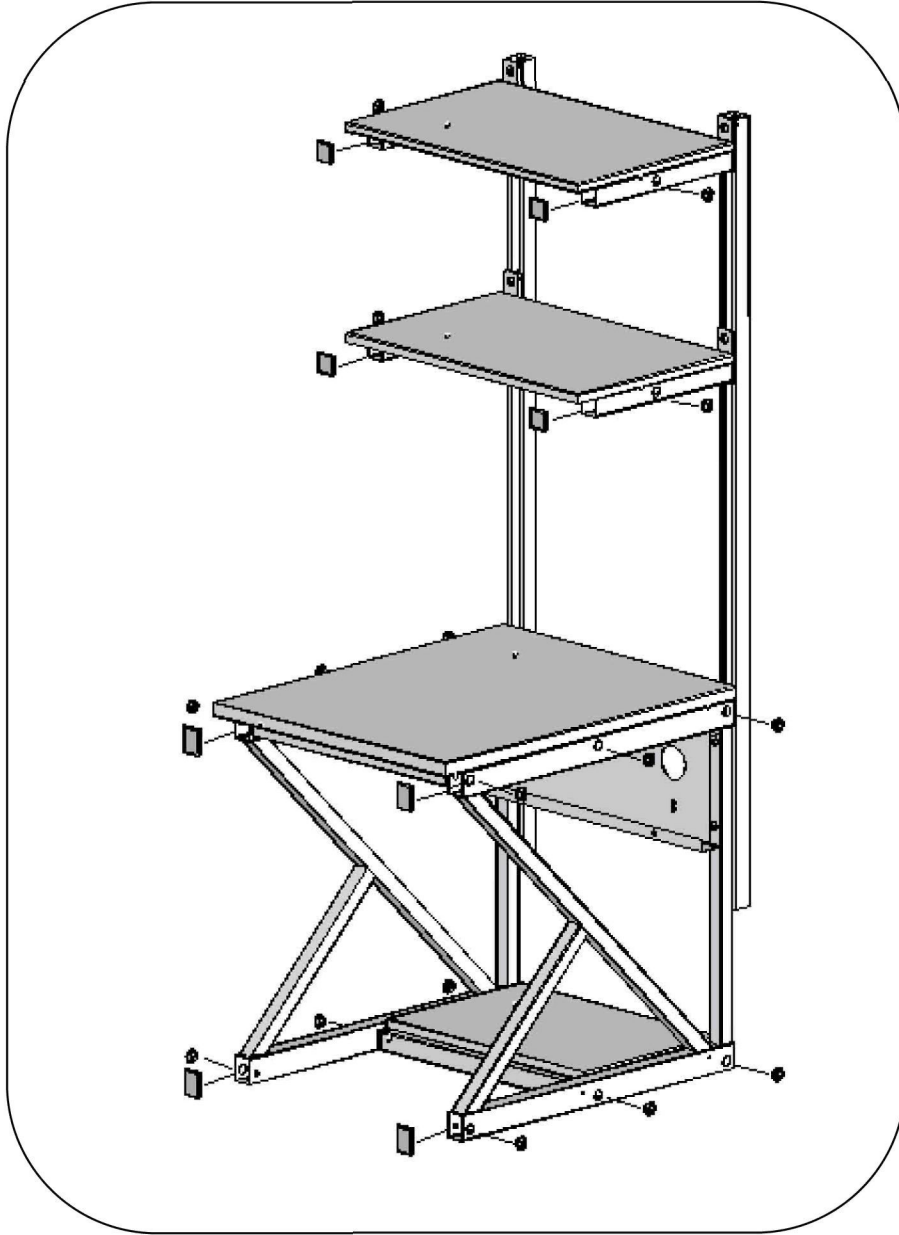

Maintaining Your New Workbench

Your new Kendall Howard Performance Workbench is constructed with some of the highest quality materials available today. To keep your Workbench looking new, we recommend cleaning it regularly damp cloth using a mild soap and water solution.

- **Do not use abrasive cleaners.**
- **Keep work surface away from petroleum products**
- **Keep away from open flames. Shelving is constructed from a wood product and is not fire proof.**
- **If you opted for casters on your bench, moving the bench around may loosen the hardware over time. Periodically check that all bolts and screws are tightened.**
- **Do not exceed the weight thresholds for your bench. This could result in serious injury or death.**



Distributed by : i-Tech Company LLC

TOLL FREE: (888) 483-2418 • EMAIL: info@iTechLCD.com • WEB: www.iTechLCD.com