

Assembly - Step 4:

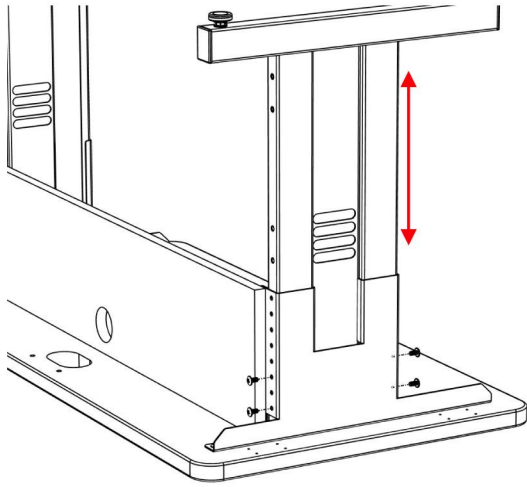

- a. Set the training table height on each leg assembly by unscrewing and sliding the leg to the desired position.
- b. Re-insert screws to secure



Instructions / Directions

36" Training Table # 5500-3-00X-XX



Distributed by : i-Tech Company LLC

TOLL FREE: (888) 483-2418

• EMAIL: info@iTechLCD.com

• WEB: www.iTechLCD.com

Tools Needed:



Screw Driver

Included:



(1) Left Leg Assembly

(1) Right Leg Assembly

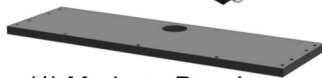

(1) Modesty Panel

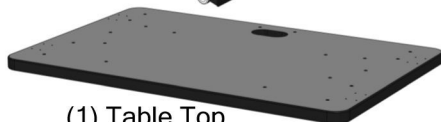

(1) Table Top



(4x) Leveler



(4x) End Cap



(1) Modesty Panel Grommet



(25x) 1/4-20 Screw



(1) Surface Grommet

Assembly - Step 1:

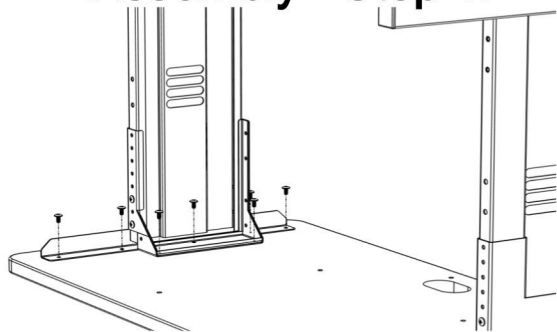

- Position table top with smooth surface facing down
- Line up leg assemblies with pre-drilled hole pattern (note - shorter side of legs face the back of the table)
- Fasten to table top with 1/4" screws

* If installing the Cable Management Enclosure leave out back two screws in the legs

2

Assembly - Step 2:

*If installing the Cable Management Enclosure, proceed to mount that to the modesty panel before assembling the panel to the training table

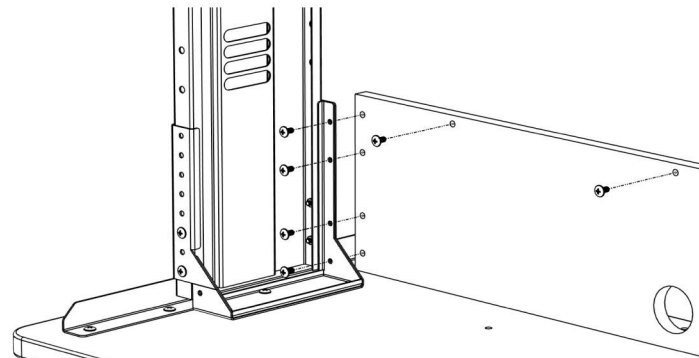

- Attach modesty panel to the back edge of the right and left leg assembly. (Make sure the grommet opening is closest to the work surface)
- Fasten with 1/4" screws.

** If not installing the Cable Management Enclosure—fill in additional threaded holes in modesty panel with additional screws.

Assembly - Step 3:

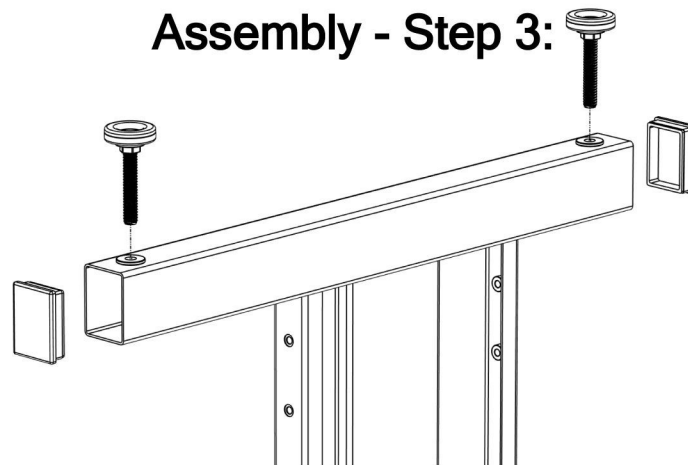

- Insert levelers into the threaded inserts in the bottom of the leg assemblies.
- Insert end caps into base of each leg kit.

3