

# Fanless PANEL PC

Panel Mount PC, 17" CCFL LCD, SXGA 1280 x 1024, 8 wires Resistance Touchscreen, VIA C7 1.5Ghz, 2GB Memory/ 250 GB HDD, 4 x COM, 2 x USB, VESA75/100, 6Kg, 64.5H x 413W x 343D

Model: LPC17VA

## Features:

Intel Atom / VIA solution, Fanless, Touch screen, Water Proof, Open-frame design, LED Backlight Panel

## Application:

Information Kiosk, POS, Mobile solution, Automation control

## Specifications

LCD Panel	AUO
Resolution	SXGA 1280 x 1024
Brightness ( cd/m2 )	350
Contrast Ratio	1000 : 1
Backlight	CCFL
Number of Colors	16.7 M
Touch Screen	AMT 8 wires / Resistive touch screen
Mounting Spec.	VESA 75 / 100
Panel frame water proof	IP65
Webcam ( Option )	5.0 Mega pixel - auto focus
Accessory ( Option )	Wall Mount Kit / Stand

## Fanless Panel PC

Panel PC Dimension	See below drawings for dimensions
Case Dimensions	See below drawings for dimensions
Front Panel Dimension	8.5 H x 413 W x 343 D mm
Material	Plastics front frame + Aluminum
Weight	4.8 Kg ( Incl. M/B )
Storage Space	2.5" / 3.5" HDD
Operation Humidity	5 ~ 90% @ 39 C, non-condensing

## M/B information:

( Please refer to M/B specification )

CPU Type	M/B Model	VGA	COM	LAN	USB	Audio	KB/MS	Others	Operation Temp.	
									CF Card	HDD
Intel Atom N270	LPC17AT2		6	1	2	YES			50°C	50°C
Intel Core 2 Duo Socket M	LPC17CD	1	6	2	4	YES		DVI		45°C
	LPC17CDB	1	2	2	4	YES	YES	DVI / TV-Out / Video-In		45°C

## More Functions

Aluminum / Stainless Case		Capacitive touch	Webcam	Parallel Port
DC +6V to +36V	High Brightness Panel	1 ~ 4 Video-IN	Bluetooth	Optional LAN
Rechargeable Battery	DIO	Speaker	Wi-Fi	GPS
3G	4 x COM	H.264 decode	USB	

The above available functions outline the possibility with system, for more information please contact us.

Dimension:

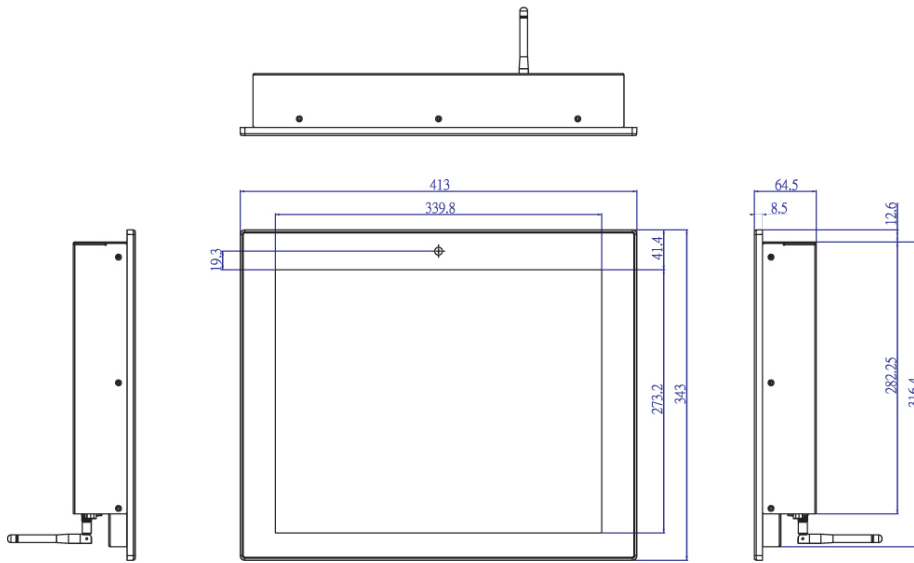

### VESA 75/100 Mounting

