

- 12.1" (4:3) Fanless industrial PC
- Intel® Atom™ N2800/D2550 Processor
- DDR3 RAM 2G on Board
- 4 COM (2\*485/422 option) + 6 USB
- 1\*SATA for 2.5"HDD/SSD, 1\* CF Socket
- 1\*VGA + 1\*HDMI + 2\*Giga LAN
- WIFI & Blue Tooth (option)
- OS support: Win7, Win XP(e), Win CE, Linux



### Specification

LCD Display	4:3
Resolution	XGA 1024 x 768
Brightness (cd/m2)	500
Contrast Ratio	700:1
Backlight	LED
Touch Screen	5 Wires/Resistive
Mounting Spec	VESA 75/Panel Mount
Panel frame water Proof	IP64
Accessory (Option)	Wall Monunt Kit/Stand
LCD Panel size	248.5 x187.4 mm
Case Dimensions	305 x 244 x 86.5 mm
Front Panel Dimensions	305 x 244 x 9.5 mm
Power Supply	Input: 100-240 VAC, 50-60 Hz Output: +12VDC, 3A
Temperature	Operating: -20~60°C Storage: -20~80°C
Humidity	0%-90%, non-condensing
Power Consumption	20W (maximum)

### I/O Type

- 6x USB2.0 (WIFI option)
- 4x COM ( or 2x RS-232 + 2x RS485/422 )
- 1x HDMI
- 1x DB 15F VGA,resolution 1920x1440 Max
- 1x CF Card Socket
- 1x DC Jack input (12V )
- 1x 12V Power In Terminal (Option)
- 1x Audio-Out
- 1x MIC-In
- 2x RJ45 LAN
- 1x Power Buttom
- 1x Power LED
- 1x HDD LED
- 1x External "Power" "Reset" signal terminal connector
- 1x Reset cave switch

### Application

Automation control,0  
POS,  
Information Kiosk,  
Mobile solution

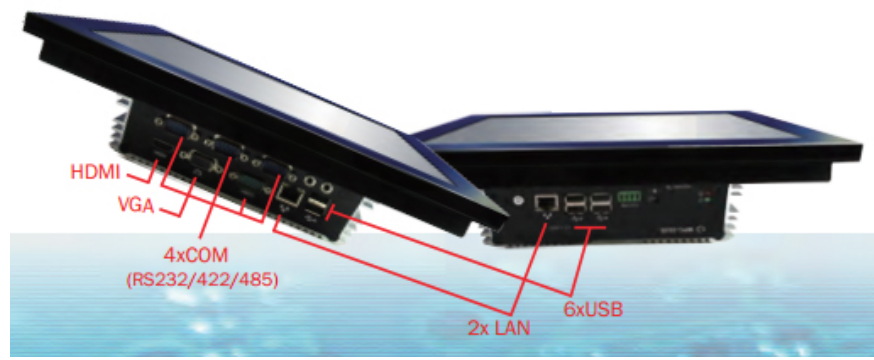

1  
 Industrial Box PC Solution

2  
 Touch Panel PC Solution

3  
 USB touch monitor Solution

4  
 Panel PC Kits Solution



# Mechanical Drawing

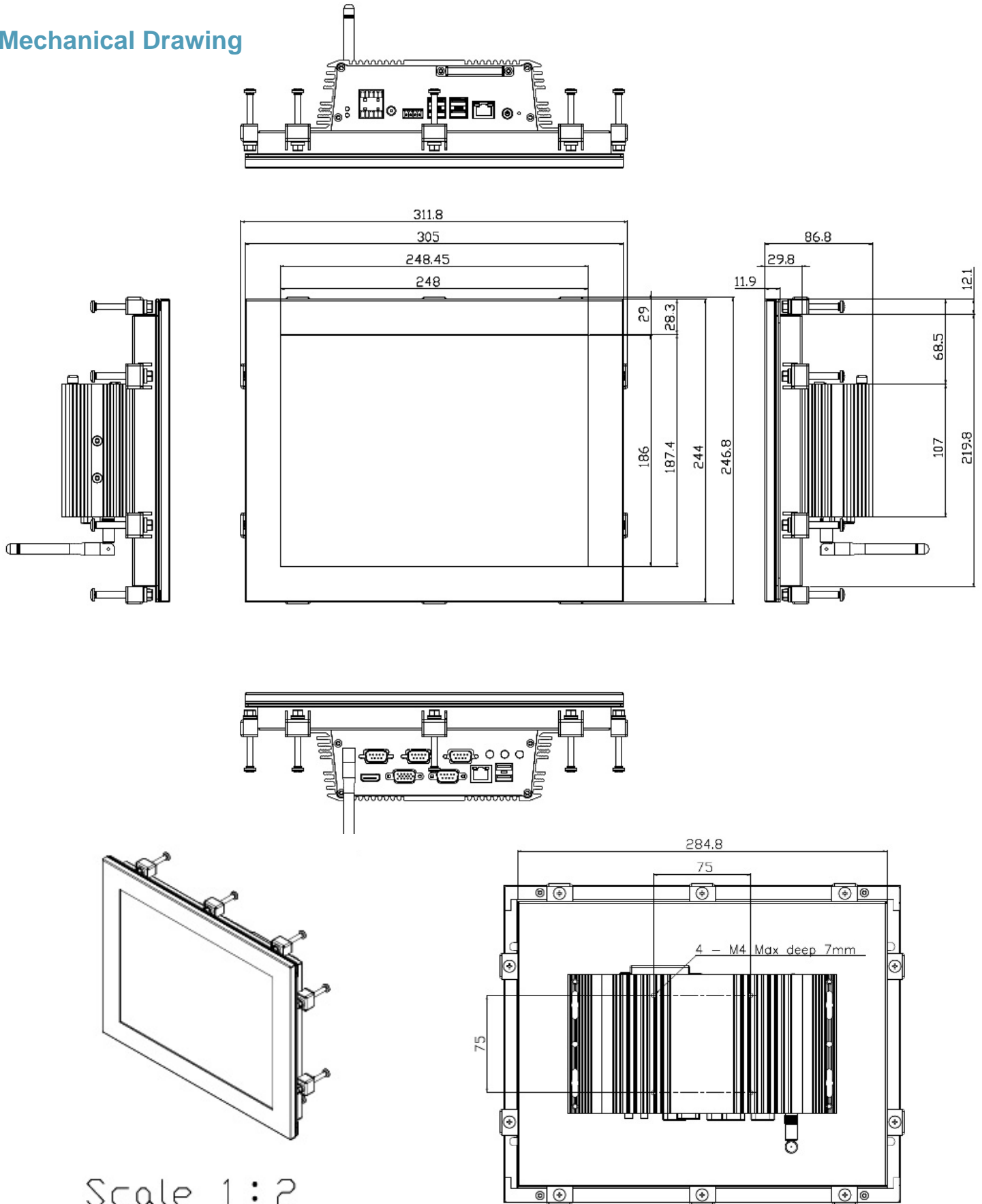

Scale 1 : 2