

RUGGED MILITARY VIDEO RECORDER

10.4" Rugged Military Digital Video Recorder

2 (or 4) Video In, 1 Video Out, 1 x VGA out
32-hr Record Time, 120G SSD, DC9~35V

Model: **NMii-1040DVR**

FEATURES:

- 10.4" TFT LCD
- Vandalism protection glass
- 800 cd/m2 brightness
- IP67 (NEMA-6 submersible) 100% water-proof design
- Record up to 64 hours (or max. 128 hours)

MECHANICAL:

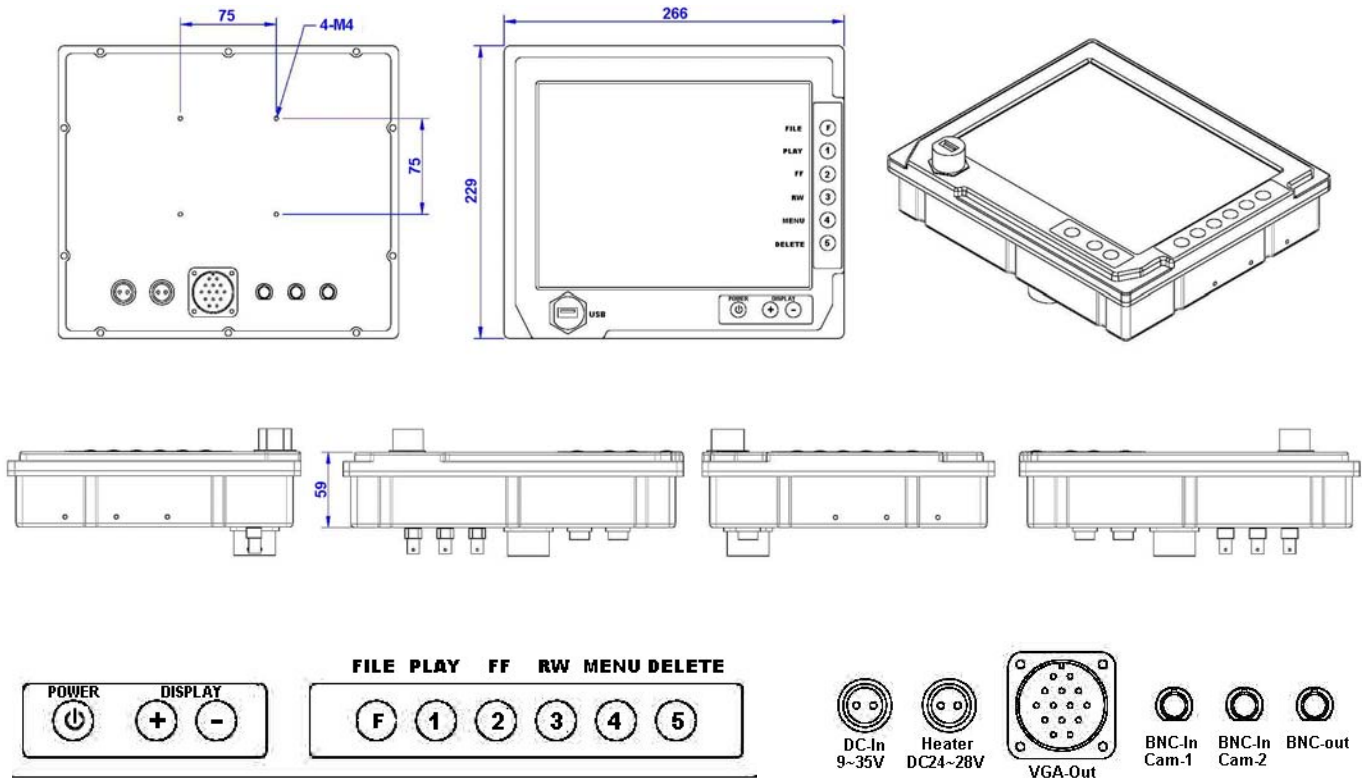

Control Buttons at Front

Connectors at Rear



SPECIFICATIONS:

LCD Size, Brightness

- 10.4" TFT LCD, 800 cd/m² high brightness
- Sunlight Readability : sunlight readability treated
- Contrast Ratio : 900 : 1

View Angle, Dimming Ratio

- View Angle : 160° / 160°
- Dimming Ratio : 3000 : 1

Protection Glass & IP-67

- Vandalism protection glass
- IP67 (NEMA-6 submersible) 100% water-proof design

Video Input & Output

- Video Input : 2 or optional 4 Video Inputs at your request
- Video Output : 1 Video Output

Connectors, Cap, Mating

- Military grade circular connector
- With protective cap and mating connector

Storage Device

- Intel 120GB SSD, provide 5-year warranty from Intel

Housing & Treatment

- Milled AL, Black hard Anodized treatment

Mounting

- Standard A-kit; support VESA-75 or other optional mount

DC Power Input & Power Protection

- Military grade 9-36V DC (12, 24, 28VDC nominal)
- Isolated, Protected against Internal Short Circuit, Load Dump, Over Voltage, and Reverse Polarity

Power Consumption

- 30 Watts maximum
- Military grade DC power supply

Recording Capacity & Video Compression

- Record up to 64 hours (or max. 128 hours)
- Video Compression : H.264 / MPEG-4

Time Stamping

- 1/100th of a second
- Storage SSD : up to 120GB capacity

USB Download Port

- Use as a remote HDD when connected to a PC

Operating & Storage Temperature

- Operating Temperature : -40°C to 80°C
- Storage Temperature : -50°C to 85°C

Humidity, Altitude

- Humidity : 0 ~ 100%
- Altitude : 45,000 feet

Environmental Test Standard

- Design to meet MIL-STD-461, MIL-STD-810, MIL-STD-3009, MIL-PRF-22885, MIL-STD-1275D, MIL-A-8625 Type III (Class 1 & 2), MIL-DTL-38999

