

NX Series

Model: NX-SD117e / NX-SD117b

1U Short Depth Rackmount 17" LCD Monitor Keyboard Combo (PS/2 and USB) KVM Switch Drawer



NETVIEW
KVM SWITCH SOLUTIONS

LCD Drawer & KVM Benefits:

- Short depth design of 480mm (18.9") only
- Depth will suit a 600mm rack application
- Single or "One Man" installation slides for easy, quick installation
- 104 key notepad keyboard with full numerical pad

LCD Features:

- 1U rackmount drawer with either 17" or 19" SAMSUNG LCD
- Either PS/2 or USB input to the LCD Drawer by cable selection
- Multiple keyboard language selections with either touchpad or trackball
- slide rails with fixed positions to prevent drawer movement when typing
- Multi lingual on screen display menu
- 12, 24 and 48 volt DC power options

Mechanical Drawing:

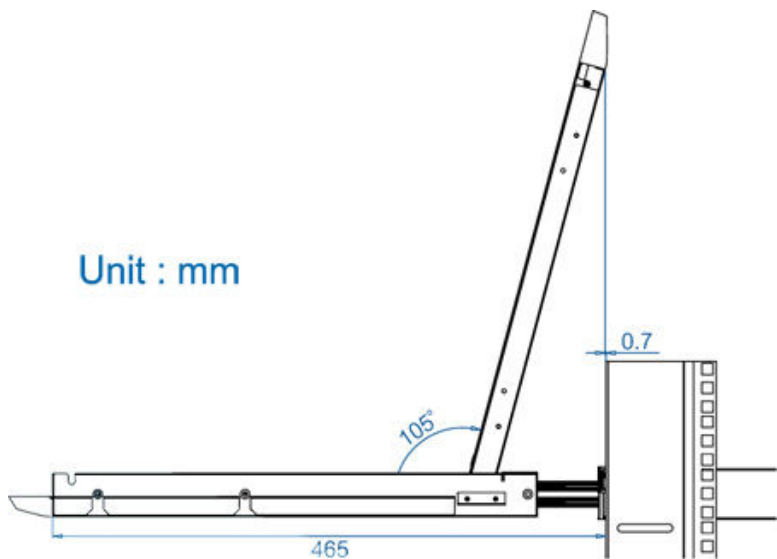

e keyboard integrated with touchpad

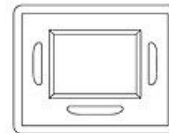
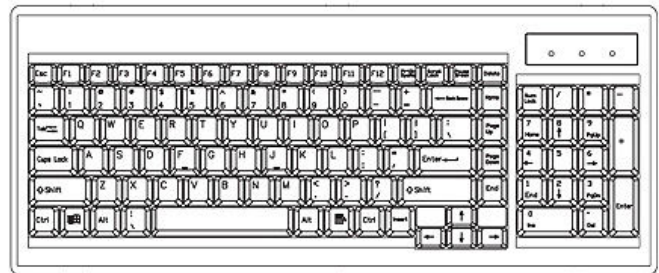

b keyboard integrated with trackball

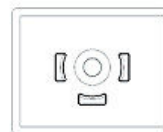
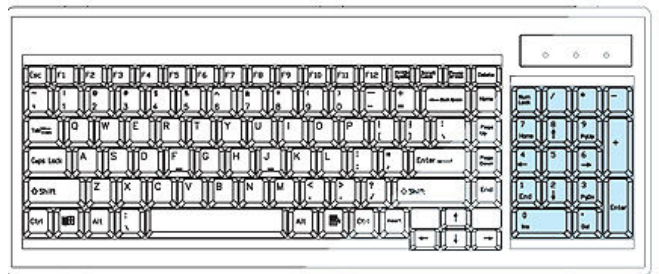

Specifications:

LCD	
Panel	Samsung 17" LCD Panel
Screen Type	TFT
Display Area	337.92(H) x 270.34(V) mm
Contrast Ratio	500 : 1
Viewing Angle	140 ° (H) x 120 ° (V) (Typ.)
Resolution	1280 x 1024
Pixel pitch	0.264(H) x 0.264(W) mm
Response Time	Tr=5ms, Tf=20ms (Typ.)
Brightness	300 cd/m2
Panel Color	16.2M
Back Light	4 CCFTs (Cold Cathode Fluorescent tube)
Video	
Horizontal Synchronization	64 - 80 KHz (Typ.)
Vertical Synchronization	60 - 75 Hz (Typ.)
Input Signal	Analog RGB 0.7Vp-p
Power Management	
VESA DPMS	
Control	
OSD Control	Brightness, Contrast, Colour, Clock, H.Position, V.Position, Phase, Scaling, Auto config, Input select, Multi window, Clear EEPROM, OSD adjust, Save
External Connection	
Power Input	12V/5A DC adapter
Video Input	15-pin D-Sub connector