

# DR Series

## 1U Rack Mount Dual Slide LCD Keyboard KVM Drawer

1U 17"/19" Dual Slide LCD Keyboard / KVM Drawer + USB+ Audio KVM switch, Audio out x 1, Includes NC-6: 6pc 6ft long DVI +USB+ Audio KVM Cables, 650mm(26 inch )Deep

Model: DR117/119



### FEATURES:

- 1U dual slide 17" or 19" LCD console drawer
- 104-key keyboard with touchpad
- Enhanced aesthetics with new molded front panel and two point lock
- Combo interface either PS/2 or USB for single console drawer
- Short depth design of 650mm(26 inch )Deep

### SPECIFICATIONS:

LCD Panel		
Manufacturer	AUO	AUO
Diagonal size	17" TFT	19" TFT
Max. Resolution	1280 x 1024	1280 x 1024
Brightness (cd/m2)	250	250
Backlight	CCFL	LED
Colors	16.7M	16.7M
Contrast Ratio (typ)	1000 : 1	1000 : 1
Viewing Angle (H/V)	160° x 160°	170° x 160°
Active area (mm)	338 x 270	376 x 301
MTBF (hrs)	50,000	30,000
Video Input	VGA	VGA
Speaker (HDMI Only)	Built-in Dual Stereo Speakers 2W x 2	
Power Input	Auto-sensing 100 to 240VAC, 50 / 60Hz	
Power Consumption (single console)		
Screen on	Max. 25W	
Power saving mode	Max. 4W	
Power button on	Max. 1W	
Environmental		
Operating temperature	0 to 55°C degree	
Storage temperature	-20 to 60°C degree	
Operating humidity	20~90%, non-condensing	
Storage humidity	5 ~90%, non-condensing	
Operating altitude	16,000 ft	
Non-operating altitude	40,000 ft	
Shock	10G acceleration ( 11ms duration )	
Vibration	5~500Hz 1G RMS random vibration	
Casing Color	Black ( RAL 9005 )	
Regulatory		
Safety	cUL, FCC & CE certified	
Environmental	RoHS2 & REACH compliant	
Weight ( single console )	Net	Gross
DR117	12.6 kgs / 27.7 lbs	18.4 kgs / 40.5 lbs
DR119	13.2 kgs / 29 lbs	19 kgs / 41.8 lbs
Dimensions ( single console )		
Product	441.6 x 650 x 44 mm / 17.4 x 25.6 x 1.73 inch	
Packing	595 x 860 x 140 mm / 23.4 x 33.9 x 5.5 inch	

## STRUCTURE DIAGRAM

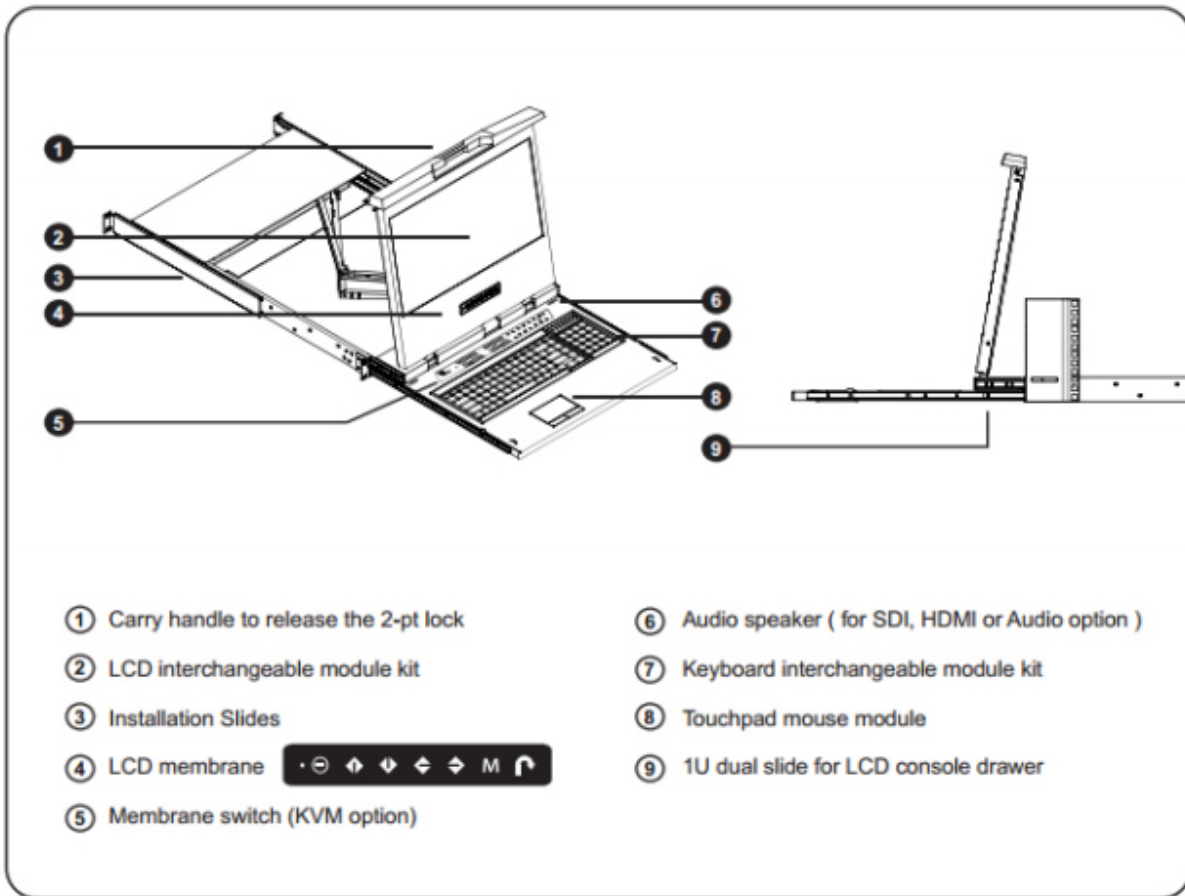

## STANDARD KEYBOARD

**e** keyboard integrated with touchpad

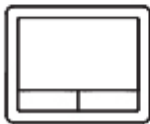
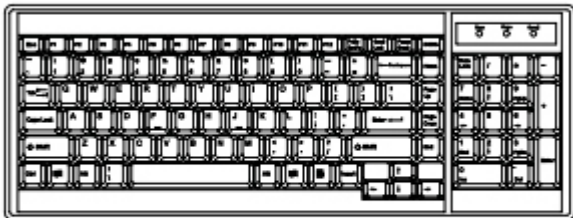

<b>America</b>		United States			
<b>EMEA</b>					
	United Kingdom	Germany	France	Spain	Norway
	Italy	Russia	Switzerland	Netherlands	Portugal
<b>Asia</b>	China	Japan	Korea	Arabia	Turkey

## KEYBOARD OPTIONS (US layout only)

**Me** Mac keyboard with touchpad



**Mb** Mac keyboard with trackball

**Se** S keyboard with touchpad

**Sb** S keyboard with trackball



## KVM OPTIONS

### ■ Dimensions ( with KVM )

Product: 441.6 x 770 x 44 mm / 17.4 x 30.3 x 1.73 inch

Packing: 595 x 860 x 140 mm / 23.4 x 33.9 x 5.5 inch

### ■ Power Consumption with KVM integration

Screen on: Max. 62W

Power saving mode: Max. 34W

### ■ Weight

Net: 15.5 kgs / 34.1 lbs

Gross : 21.4 kgs / 47.1 lbs

### ■ Casing Color

Black ( RAL 9005 )

X stands for 17" or 19" LCD size.

For keyboard option add (e) touchpad or (b) trackball at the end of the model no.

Sample: DR11X-MC1116e

Matrix Cat6 KVM	Local	Remote	IP	8-port	16-port	32-port
	1	1	1	-	DR11X-MC1116	DR11X-MC1132
1	1	2	-	DR11X-MC2116	DR11X-MC2132	
1	1	0	-	DR11X-MC0116	DR11X-MC0132	
1	2	0	-	DR11X-MC0216	DR11X-MC0232	
1	3	0	-	DR11X-MC0316	DR11X-MC0332	

Combo Cat6 KVM	Local	Remote	IP	8-port	16-port	32-port
	1	0	1	DR11X-CIP8	DR11X-CIP16	DR11X-CIP32
1	1	0	DR11X-CCE8	DR11X-CCE16	DR11X-CCE32	
1	0	0	DR11X-C8	DR11X-C16	DR11X-C32	

Cat6 KVM Dongle : DG-100S ( VGA-USB ) / DG-100 ( VGA-PS/2 ) / DG-100SD ( DVI-USB )

Matrix DB-15 KVM	Local	Remote	IP	8-port	16-port	32-port
	1	1	1	DR11X-M118	DR11X-M1116	-
1	1	2	DR11X-M218	DR11X-M2116	-	
1	1	0	DR11X-M018	DR11X-M0116	-	
1	2	0	DR11X-M028	DR11X-M0216	-	
1	3	0	DR11X-M038	DR11X-M0316	-	

Combo DB-15 KVM	Local	Remote	IP	8-port	16-port	32-port
	1	0	1	DR11X-IP8	DR11X-IP16	-
1	1	0	DR11X-8	DR11X-16	-	
1	0	0	DR11X-S801	DR11X-S1601	-	

Combo DB-15 KVM Cable : NE-6 / 10 / 15 ( 6, 10 or 15 ft )

DVI-D KVM	Local	Remote	IP	12-port	-	-
	1	0	0	DR11X-12D	-	-

USB Hub DB-15 KVM	Local	Remote	IP	8-port	16-port	32-port
	1	0	1	DR11X-IPB8	DR11X-IPB16	-
1	1	0	DR11X-B82	DR11X-B162	-	
1	0	0	DR11X-B8	DR11X-B16	-	

## DIMENSION

Front View

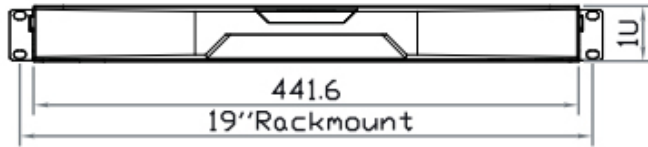

Rear View



Side View

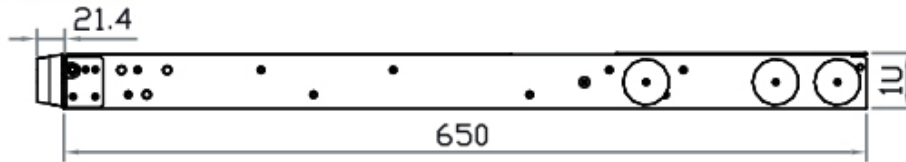

UNIT : mm  
1mm = 0.03937 inch

Top View

