



Model: ROP1500

15" Open Frame Color Display Flat Panels

Engineered Solutions

As display technologies evolve, so do our customer's imaginations. i-Tech continues to lead the way in engineering solutions to meet the diverse needs of the display marketplace. Whether your application is for a kiosk, CRT replacement, HMI, POS, Public Information Display or Digital Signage, this is the simple all-in-one solution for you. Easily integrated, we combine performance and quality with the versatility of an open frame chassis mountable product. Select from a wide variety of optional touch screens, protective glass, films or privacy shields. i-Tech custom designs and builds for OEM's, providing custom enclosures, private label products, display selection assistance, SBC selection and integration, special power requirements and customized warranty and service programs.

- A-Si Active Matrix TFT Color LCD Panel
- VGA and DVI connections, optional NTSC/PAL, S-Video
- Lightweight but rugged design
- Superb Quality - clear, bright, high contrast ratio with wide viewing angle
- Detects the sync type (separate, composite or sync on green) automatically
- Perfect for VARs, System Integrators and OEM's
- Optional Touch Screens - Capacitive, Resistive or SAW
- Available with Protective Shields (AR/AG or Clear) or Privacy Shields



Specifications	RCH1500
LCD Size	15.0"
Standard Resolution	1024 x 768
Pixel Pitch	0.297 mm
Pixel Arrangement	RGB Vertical Stripe
Brightness (typical)	250 cd/m ²
Contrast Ratio	500:1
Aspect Ratio	4:3
Response Time (typical)	12 ms
Viewable Area	304.128 mm (H) x 228.096 mm (V)
Horizontal Viewing Angle	130°
Vertical Viewing Angle	120°
Color Depth	16.2 Million
Input Signal	Analog
Input Connector	15Pin D-Sub, Optional NTSC/PAL, S-Video, DVI
Frequency Range	30KHz - 80KHz (H), 50Hz - 75Hz (V)
Power Supply Input (external)	DC 12V, 100 - 240V, 50 - 60Hz
Power Supply Output (external)	12V @ 3.5A
Power Consumption	12VDC @ 2.0A
Lamp Life	50,000 Hours
Operating Environment	0°C - 50°C
Relative Humidity	8% - 90% non-condensing
Storage Environment	-20°C - 60°C
Relative Humidity	8% - 90% non-condensing
Operating Altitude	10,000 Feet
Storage Altitude	30,000 Feet
Dimensions (WxHxD)	15.41" x 11.73" x 1.60"
Gross Weight	6.3 lbs
Color	Black or Custom
Warranty	1 Year





Model: ROP1500

15" Open Frame Color Display Flat Panels

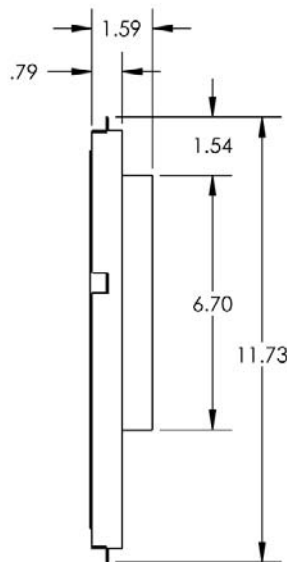
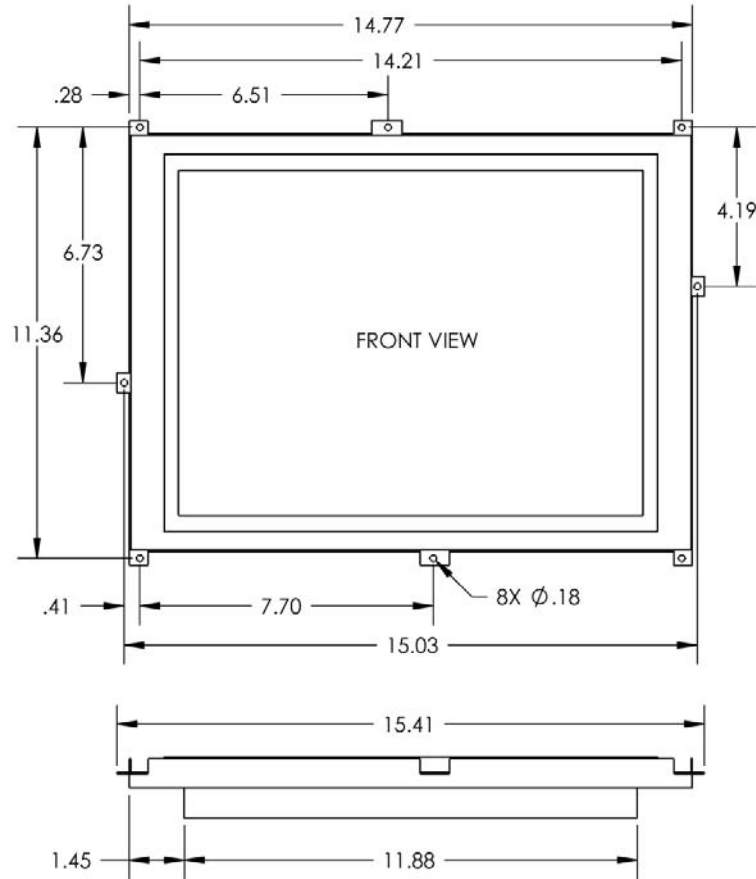

Toll Free: 1-888-itech-18 Fax: 1-510-372-2736 E-mail: infor@i-techcompany.com

www.i-techcompany.com www.i-techcompany.com www.i-techcompany.com www.i-techcompany.com