



**Rugged Completely Sealed IP66/NEMA4X  
Stainless Steel Chassis/Surface Mount**

## SCHW3200HB-SIP

32" High Brightness LCD monitor LED backlight, 1920 x 1080, 1000 nits, with 2mm AR glass, VGA and DVI input

### FEATURES

- 32" Bright Active Matrix TFT Display, 1000 Nits (cd/m<sup>2</sup>)
- 1920 x 1080 High Resolution
- NEMA 4X (IP66) 304 Stainless Steel Gasket Sealed Enclosure
- Input Interface VGA + DVI-D
- Included all water proof connectors and 6ft long water proof cables.
- LED backlight Energy Efficient, Low Power Consumption
- High Environmental Performance and Reliability
- Anti-Reflective Protective Glass
- Wide Operational Temperature Range, 0°C to +50°C (32°F to +122°F)
- RoHS Compliant
- VESA mount compliant.



NEMA 4X



VESA Mount



High Contrast



Low Power



Wide Viewing  
Angle

### OPTIONS

- Optional for integrated computer Atom D2550 1.86 Hz, 32GB Wide temp SSD and 4GB Memory (DVI x 1 + RS232 x 1 + USB x 2 + POWER x 1 + LAN x 1)
- Optional Custom fitting for purging the monitor's enclosure
- Optional for 9-36V DC input
- Optional 5 Wired Resistive touch/ IR/ PCap Touch Screen (USB Default/ RS232 per request controller)
- Optional High Brightness 1000nits For Semi outdoor application
- Optional for Auto Dimming Sensor
- Optional for IR Remote Control with Front Sensor.
- Optional Heater for lower temperatures -30C (-22F)
- Optional Integrated VGA/ DVI Extender
- Transmission length up to 1,000ft over CAT5e cable for VGA input
- Transmission length up to 300ft over CAT5e cable for DVI input

### Rugged Completely Sealed IP66/NEMA4X Stainless Steel Chassis/Surface Mount LCD Monitor



**Water Proof Solution,  
Full IP NEMA4 Rating  
front and back**

**Stainless and  
Aluminum Housing  
Chassis Design**

**AR Glass  
Protective Glass at  
front**

**Optional High  
Brightness and  
Touch screen**

**\* IP65 Water and Dust proof  
connection for a higher protection**

**\* All Connectors are facing backward**



i-Tech Company LLC  
TOLL FREE: (888) 483-2418  
• EMAIL: [info@itechlcd.com](mailto:info@itechlcd.com)  
• WEB: [www.iTechLCD.com](http://www.iTechLCD.com)



USA Based Company. Most of our Industrial LCD Monitor are assembled, tested, shipped from our CA headquarter, giving us the ability to provide best service to your needs.

## SPECIFICATION

LCD Display	
Size / Panel Type	32" TFT LCD Panel
Resolution	1920 x 1080
Brightness (cd/m <sup>2</sup> )	1000 cd/m <sup>2</sup>
Contrast Ratio	1450 : 1
Response Time	5 ms
Backlight	LED Backlight Unit
Colors	1.06Billion colors
Viewing Angles	178°/178°
Surface Hardness	7~8H, AR Glass
Touch Screen (Optional)	
Touch Screen Type	IP65 Front bezel if add IR Touch (Optional)
Surface Hardness	7~8H
Environment	
Operating Temperature	0°C~+50°C
Storage Temperature	-20°C~+60°C
Humidity	5%~95% RH(Non-Condensing)
Water-Proof Rating	IP66/NEMA4, 6 Side Water-Proof

System	
OSD	Menu, Auto, On/Off, Up, Down
I/O Interface	VGA x 1, DVI x 1, Power in x 1
Power Input	AC100~240V
Power Consumption	130W
Certification	FCC/CE/RoHS Compliance
Mounting	VESA 400 x 200mm
Dimension/Weight	811mm (W) x 506mm (H) x 85.4mm (D)/31kgs

## ACCESSORIES

Water proof VGA cables 6ft long x 1
Water proof DVI cables 6ft long x 1
External Power Adapter x 1

## PHOTO GALLERY



## MECHANICAL DRAWINGS

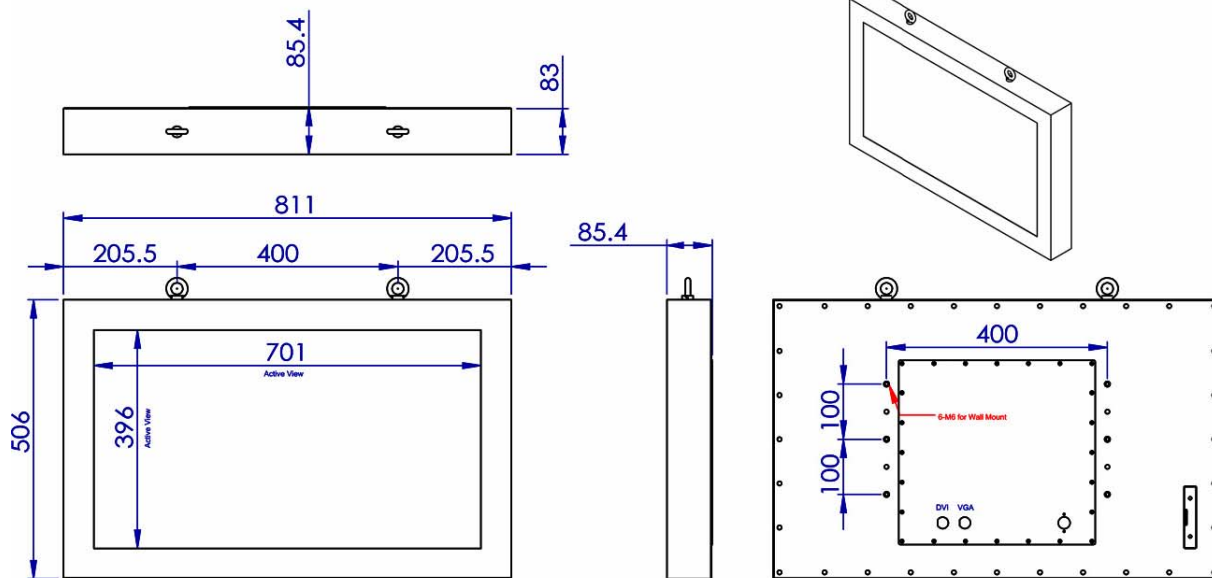

i-Tech Company LLC  
TOLL FREE: (888) 483-2418  
• EMAIL: [info@itechlcd.com](mailto:info@itechlcd.com)  
• WEB: [www.iTechLCD.com](http://www.iTechLCD.com)



USA Based Company. Most of our Industrial LCD Monitor are assembled, tested, shipped from our CA headquarter, giving us the ability to provide best service to your needs.