



Rugged Completely Sealed IP66/NEMA4X Stainless Steel Chassis/Surface Mount Panel PC

SCHW5500-SIP-PC

55" Panel PC LCD monitor LED backlight, 1920 x 1080, 450 nits, with 2mm AR glass and DVI with Intel® Atom D2550 Processor and NM10 onboard



NEMA 4X



VESA Mount



High Contrast



Low Power



Wide Viewing
Angle



Built-in
PC

FEATURES

- 55" Bright Active Matrix TFT Display, 450 Nits (cd/m²)
- 1920 x 1080 High Resolution
- Built-in Intel Atom D2550 Dual Core 1.86Ghz CPU, Fanless Design, 32GB Wide temp SSD and 4GB Memory (DVI x 1 + RS232 x 1 + USB x 2 + POWER x 1 + LAN x 1)
- NEMA 4X (IP66) 304 Stainless Steel Gasket Sealed Enclosure
- DVI-D only for external video input
- Included all water proof connectors and 6ft long water proof cables.
- LED backlight Energy Efficient, Low Power Consumption
- High Environmental Performance and Reliability
- Anti-Reflective Protective Glass
- Wide Operational Temperature Range, 0°C to +50°C (32°F to +122°F)
- RoHS Compliant
- VESA mount compliant.

OPTIONS

- Optional Custom fitting for purging the monitor's enclosure
- Optional for 9-36V DC input
- Optional 5 Wired Resistive touch/ IR/ PCap Touch Screen (USB Default/ RS232 per request controller)
- Optional High Brightness 1000nits For Semi outdoor application
- Optional for Auto Dimming Sensor
- Optional for IR Remote Control with Front Sensor.
- Optional Heater for lower temperatures -30C (-22F)
- Optional Integrated VGA/ DVI Extender
 - Transmission length up to 1,000ft over CAT5e cable for VGA input
 - Transmission length up to 300ft over CAT5e cable for DVI input

Rugged Completely Sealed IP66/NEMA4X Stainless Steel Chassis/Surface Mount LCD Monitor



Water Proof Solution,
Full IP NEMA4 Rating
front and back

Stainless and
Aluminum Housing
Chassis Design

AR Glass
Protective Glass at
front

Optional High
Brightness and
Touch screen

* IP65 Water and Dust proof
connection for a higher protection

* All Connectors are facing backward



i-Tech Company LLC
TOLL FREE: (888) 483-2418
• EMAIL: info@itechlcd.com
• WEB: www.iTechLCD.com



USA Based Company. Most of our Industrial LCD Monitor are assembled, tested, shipped from our CA headquarter, giving us the ability to provide best service to your needs.

SPECIFICATION

LCD Display	
Size / Panel Type	55" TFT LCD Panel
Resolution	1920 x 1080
Brightness (cd/m ²)	450 cd/m ²
Contrast Ratio	4000 : 1
Response Time	6.5 ms
Backlight	LED backlight unit
Colors	1073.7M colors
Viewing Angles	178°/178°
Surface Hardness	7~8H, AR Glass
Touch Screen (Optional)	
Touch Screen Type	IP65 Front bezel if add IR Touch (Optional)
Surface Hardness	7~8H (AR Glass)
Environment	
Operating Temperature	0°C~+50°C
Storage Temperature	-20°C~+60°C
Humidity	5%~95% RH(Non-Condensing)
Water-Proof Rating	IP66/NEMA4, 6 Side Water-Proof

System	
CPU / Memory	Intel Atom D2550 Dual Core 1.86Ghz / 4GB DDR3
OSD	Menu, Auto, On/Off, Up, Down
I/O Interface	DVI x 1 + RS232 x 1 + USB x 2 + POWER x 1 + LAN x 1
Power Input	AC100~240V
Power Consumption	230W
Certification	FCC/CE/RoHS Compliance
Mounting	400 x 200mm (VESA); 400 x 340mm
Dimension/Weight	1313mm (W) x 784mm (H) x 75mm (D)/62kgs

ACCESSORIES

Water proof DVI cable 6ft long x 1
Water proof LAN cable 6ft long x 1
Water proof Power cable 6ft long x 1
RS232 Connector 6ft long x 1
USB Connector 6ft long x 2

PHOTO GALLERY



MECHANICAL DRAWINGS

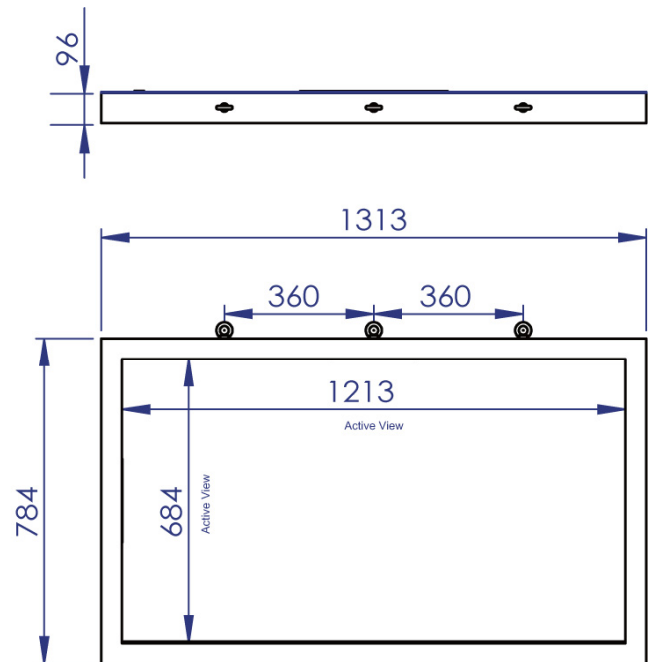
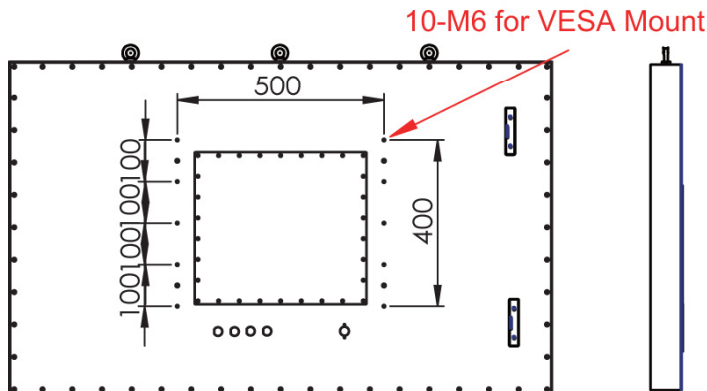

Unit:mm



i-Tech Company LLC
TOLL FREE: (888) 483-2418
• EMAIL: info@itechlcd.com
• WEB: www.iTechLCD.com



USA Based Company. Most of our Industrial LCD Monitor are assembled, tested, shipped from our CA headquarter, giving us the ability to provide best service to your needs.