



1000 nits

Rugged Completely Sealed IP66/NEMA4X
Stainless Steel Chassis/Surface Mount Panel PC

Model: SCHW5500HB-SIP-PC5

55" High Brightness Panel PC LCD monitor LED backlight, 1920 x 1080, 1000 nits, with 2mm AR glass and DVI input, Integrated with i5 processor QM77 2.7 GHz

FEATURES

- 55" Bright Active Matrix TFT Display, 1000 Nits (cd/m²)
- 1920 x 1080 High Resolution
- Integrated with i5 processor QM77 2.7 GHz, 32GB SSD/0~70C, 4GB Memory, Win 7 pro 32bit OS, DVI(for video signal input), LAN, RS232, USB * 2, Power x 1 waterproof connectors & cables (6ft)
- NEMA 4X (IP66) 304 Stainless Steel Gasket Sealed Enclosure
- DVI-D only for external video input
- Included all water proof connectors and 6ft long water proof cables.
- LED backlight Energy Efficient, Low Power Consumption
- High Environmental Performance and Reliability
- Anti-Reflective Protective Glass
- Wide Operational Temperature Range, 0°C to +50°C (32°F to +122°F)
- RoHS Compliant
- VESA mount compliant.



NEMA 4X



VESA Mount



High Contrast



Low Power



Wide Viewing Angle



Built-in PC

OPTIONS

- Optional Custom fitting for purging the monitor's enclosure
- Optional for 9-36V DC input
- Optional 5 Wired Resistive touch/ IR/ PCap Touch Screen (USB Default/ RS232 per request controller)
- Optional High Brightness 1000nits For Semi outdoor application
- Optional for Auto Dimming Sensor
- Optional for IR Remote Control with Front Sensor.
- Optional Heater for lower temperatures -30C (-22F)
- Optional Integrated VGA/ DVI Extender
- Transmission length up to 1,000ft over CAT5e cable for VGA input
- Transmission length up to 300ft over CAT5e cable for DVI input

Rugged Completely Sealed IP66/NEMA4X Stainless Steel Chassis/Surface Mount LCD Monitor



Water Proof Solution, Full IP NEMA4 Rating front and back

Stainless and Aluminum Housing Chassis Design

AR Glass Protective Glass at front

Optional High Brightness and Touch screen

* IP65 Water and Dust proof connection for a higher protection

* All Connectors are facing backward



i-Tech Company LLC
 TOLL FREE: (888) 483-2418
 • EMAIL: info@itechlcd.com
 • WEB: www.iTechLCD.com



USA Based Company. Most of our Industrial LCD Monitor are assembled, tested, shipped from our CA headquarter, giving us the ability to provide best service to your needs.

SPECIFICATION

LCD Display	
Size / Panel Type	55" TFT LCD Panel
Resolution	1920 x 1080
Brightness (cd/m ²)	1000 cd/m ²
Contrast Ratio	4000 : 1
Response Time	6.5 ms
Backlight	LED backlight unit
Colors	1073.7M colors
Viewing Angles	178°/178°
Surface Hardness	7~8H, AR Glass
Touch Screen (Optional)	
Touch Screen Type	IP65 Front bezel if add IR Touch (Optional)
Surface Hardness	7~8H (AR Glass)
Environment	
Operating Temperature	0°C~+50°C
Storage Temperature	-20°C~+60°C
Humidity	5%~95% RH(Non-Condensing)
Water-Proof Rating	IP66/NEMA4, 6 Side Water-Proof

System	
CPU / Memory	i5 processor QM77 2.7 GHz, 32GB SSD/0~70C,4GB Memory
OSD	Menu, Auto, On/Off, Up, Down
I/O Interface	DVI x 1 + RS232 x 1 + USB x 2 + POWER x 1 + LAN x 1
Power Input	AC100~240V
Power Consumption	230W
Certification	FCC/CE/RoHS Compliance
Mounting	400 x 200mm (VESA); 400 x 340mm
Dimension/Weight	1313mm (W) x 784mm (H) x 75mm (D)/62kgs

ACCESSORIES

Water proof DVI cable 6ft long x 1
Water proof LAN cable 6ft long x 1
Water proof Power cable 6ft long x 1
RS232 Connector 6ft long x 1
USB Connector 6ft long x 2

PHOTO GALLERY



MECHANICAL DRAWINGS

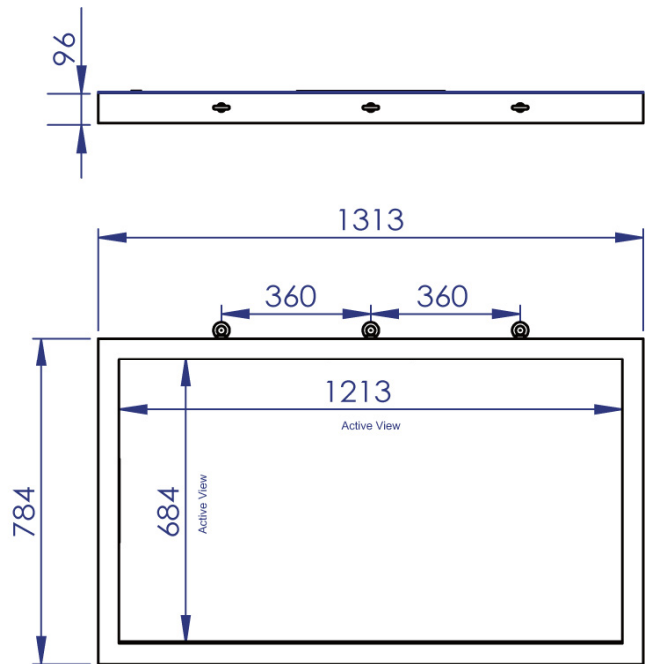
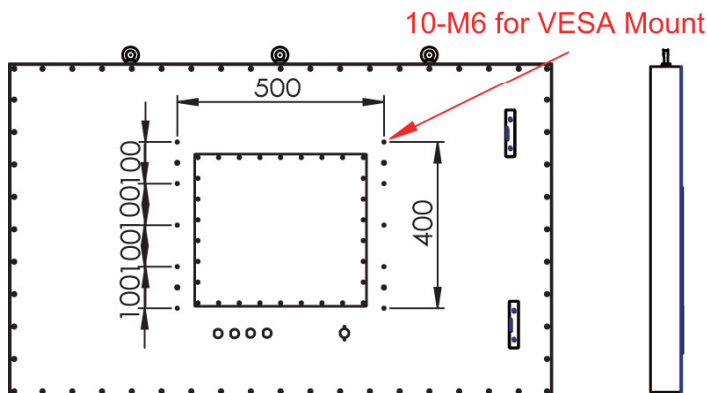

Unit:mm



i-Tech Company LLC
 TOLL FREE: (888) 483-2418
 • EMAIL: info@itechlcd.com
 • WEB: www.iTechLCD.com



USA Based Company. Most of our Industrial LCD Monitor are assembled, tested, shipped from our CA headquarter, giving us the ability to provide best service to your needs.