

Rugged Completely Sealed IP66/NEMA4X
Stainless Steel Chassis/Surface Mount

SCHW6500HB-SIP-IR

65" High Brightness LCD monitor LED backlight, 1920 x 1080, 1000 nits, with 2mm AR glass, VGA and DVI input, with IR touch Screen and USB Controller



NEMA 4X



VESA Mount



High Contrast



Low Power



Wide Viewing
Angle

FEATURES

- 65" Bright Active Matrix TFT Display, 1000 Nits (cd/m²)
- 1920 x 1080 High Resolution
- NEMA 4X (IP66) 304 Stainless Steel Gasket Sealed Enclosure
- Input Interface VGA + DVI-D
- Included all water proof connectors and 6ft long water proof cables.
- LED backlight Energy Efficient, Low Power Consumption
- High Environmental Performance and Reliability
- Anti-Reflective Protective Glass
- Wide Operational Temperature Range, 0°C to +50°C (32°F to +122°F)
- RoHS Compliant
- VESA mount compliant.

OPTIONS

- Optional custom fitting for integrated computer Atom D2550 1.86 Hz, 32GB Wide temp SSD and 4GB Memory (DVI x 1 + RS232 x 1 + USB x 2 + POWER x 1 + LAN x 1
- Optional Custom fitting for purging the monitor's enclosure
- Optional for 9-36V DC input
- Optional 5 Wired Resistive touch/ IR/ PCap Touch Screen (USB Default/ RS232 per request controller)
- Optional High Brightness 1000nits For Semi outdoor application
- Optional for Auto Dimming Sensor
- Optional for IR Remote Control with Front Sensor.
- Optional Heater for lower temperatures -30C (-22F)
- Optional Integrated VGA/ DVI Extender
- Transmission length up to 1,000ft over CAT5e cable for VGA input
- Transmission length up to 300ft over CAT5e cable for DVI input

Rugged Completely Sealed IP66/NEMA4X Stainless Steel Chassis/Surface Mount LCD Monitor

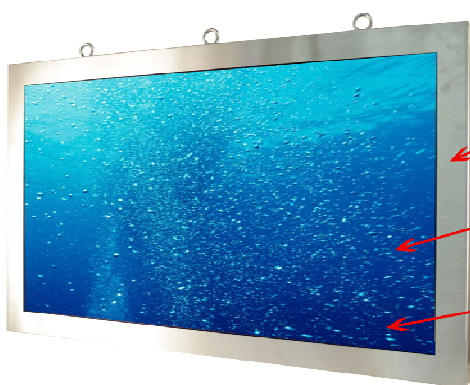

Water Proof Solution,
Full IP NEMA4 Rating
front and back

Stainless and
Aluminum Housing
Chassis Design

AR Glass
Protective Glass at
front

Optional High
Brightness and
Touch screen

* IP65 Water and Dust proof
connection for a higher protection

* All Connectors are facing backward



i-Tech Company LLC
TOLL FREE: (888) 483-2418
• EMAIL: info@itechlcd.com
• WEB: www.iTechLCD.com



USA Based Company. Most of our Industrial LCD Monitor are assembled, tested, shipped from our CA headquarter, giving us the ability to provide best service to your needs.

SPECIFICATION

Panel	Cell Type / Glass Surface	TFT LCD / Black Anti-Glare, low reflection coating	
	Aspect Ratio / Size	Wide / 65" viewable diagonal area	
	Active Area / Pixel Pitch	1428.48(H) x 803.52(V) mm / 0.744(H) x 0.744(V) mm	
	Native Resolution / Colors	1920(H) x 1080(V) / 16.7Million	
	Brightness / Contrast	1000 cd/m ² (typ) / 3000 : 1	
	Response Time	≤ 8 ms	
	Viewing Angle (typical)	H. 178o (- 89o ~ + 89o) , V. 178o(- 89o ~ + 89o)	
	Light Source	LED backlight, Long life, 35,000 hrs (typ)	
Input Sources	PC System	Signal	Analog RGB (0.7/1.0 V _{p-p} , 75 ohms)
		Sync	Separate Sync, Composite Sync, Sync On Green
		Frequency	F _h : 30 - 82Khz , F _v : 50 -75Hz
	Audio System	2W speaker x 2	
Input Terminals	1 x VGA (15 Pin Female D-Sub) , 1 x PC Audio (Stereo Headphone Jack) , 1 x DC Power Plug		
Convenient Features	Auto Calibration , Back Light Adjustment , Plug&Play (VESA DDC/CI, DDC 2B)		
	OSD Multi-Languages , Wall Mount Ready (VESA 75 x 75 mm)		
Power	Internal power supply with universal / Auto-Sensing, AC 90 to 260V, 50 / 60 Hz		
Power Consumption	Operation / Power Saving	630 watt , < 5 watt (Support DPMS)	
Operating Condition	Temperature / Humidity	0°C ~ 50°C (32°F ~ 122°F) , 10% ~ 90% (no condensation)	
Storage Condition	Temperature / Humidity	- 20°C ~ 60°C (- 4°F ~ 140°F) , 10% ~ 90% (no condensation)	
Certification	FCC , CE		
Dimensions	Physical	W x H x D = TBD	
	Carton	W x H x D = TBD	
Weight	N.W. / G.W.	65 Kgs / 69 Kgs	
Container Loaded	20ft / 40ft / 40ft HQ	TBD (Sets , By pallet)	

Options	Touch	Video / TV	Enhanced Panel	Others
	Resistive touch	SV + AV	Panel with LED backlight	Digital Signage(Stand alone)
	Capacitive touch	SV + AV + AV Looping	High brightness panel	Networking Digital Signage
	SAW touch	SV + AV + TV	Wide Temperature	Motion Sensor
	Infrared touch		Sunlight Readable	Light Sensor
	Protected glass			Auto-Dimming

ACCESSORIES

Water proof VGA cables 6ft long x 1
Water proof DVI cables 6ft long x 1
External Power Adapter x 1

PHOTO GALLERY



MECHANICAL DRAWINGS

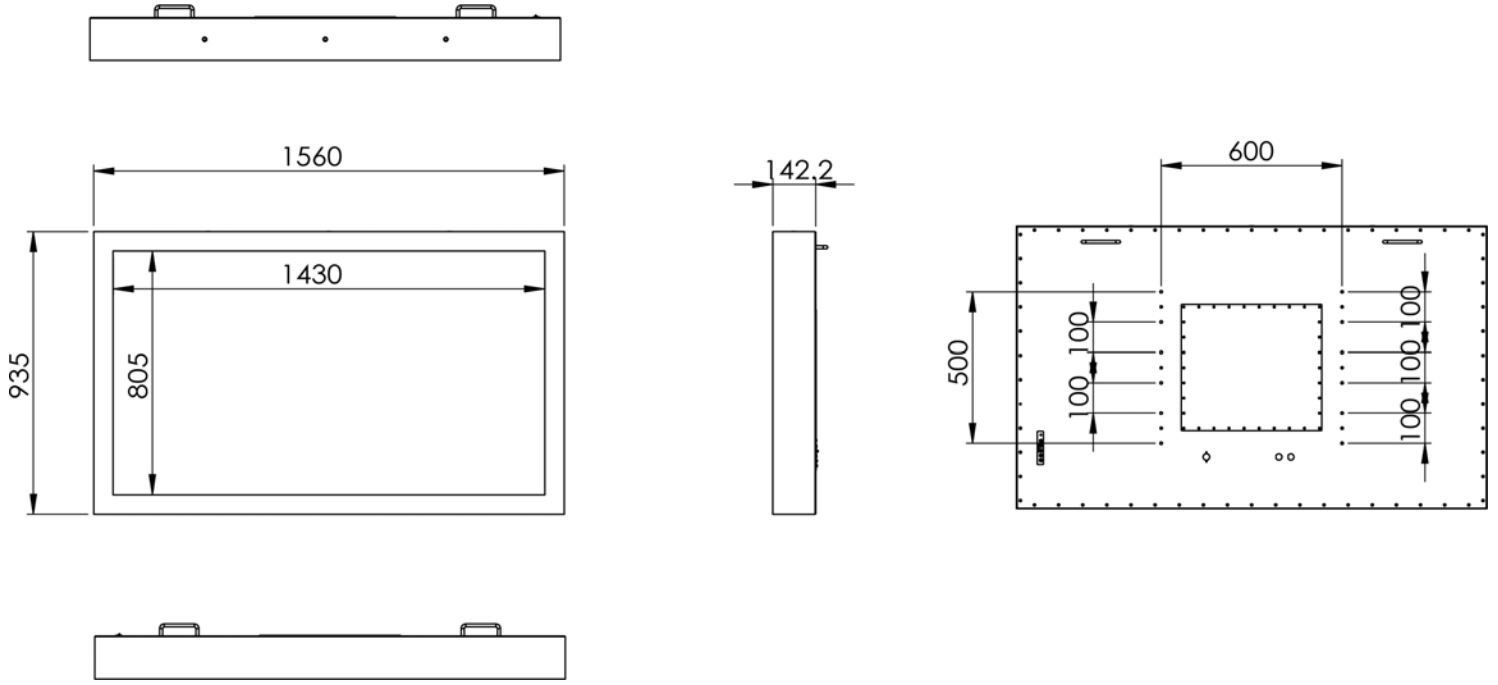

i-Tech Company LLC
TOLL FREE: (888) 483-2418
• EMAIL: info@itechlcd.com
• WEB: www.iTechLCD.com



USA Based Company. Most of our Industrial LCD Monitor are assembled, tested, shipped from our CA headquarter, giving us the ability to provide best service to your needs.