

# SL-89

## Rubber Keyboard in Aluminum Backplate

The SL-89 is a thin keyboard that features adjustable green backlighting that is also available in a night vision (NVIS) compatible configuration. It has integrated mounting holes and a right-angle USB cable that is 14.5" (0.4 m) in length when coiled. This keyboard is excellent for military applications. (Swedish layout shown in photo)



### Technical Specifications

Certifications	CE UL60950, FCC Part 15 Class B
Shock	3 x 11 ms pulses of 50g on each of 3 axes
Cable	Right-Angle USB: 14.5" (0.4 m) coiled
Key Switch	MATERIAL: Industrial Silicone Rubber LIFE: Greater than 10 Million Cycles TRAVEL: 0.055 in. (1.4mm) A ACTUATION FORCE: 6.35 oz +/- 1.06 oz (180g +/- 30g) FEEDBACK: Tactile with Mechanical Snap
Vibration	POWER SPECTRAL DENSITY: .04g/HZ FREQUENCY RANGE: 20Hz-2Khz DURATION OF TEST PER AXIS: 3 hours
Power	USB: 200 mA@5V (from CPU port)
Temperature Range	STORAGE: -40C to +90C (-40F to +194F) OPERATING: -40C to +70C (-40F to +158F)
Weight	2.0 lbs +/- 0.10 lbs (0.91 kg +/- 0.05 kg)
Warranty	1 Year Limited
Humidity	100% Humidity Resistant
Dimensions	9.88" x 7.84" x 0.62" (w-h-d) 251.0mm x 199.1mm x 15.7mm

### Features and Benefits

- 12 Function Keys
- Aluminum Backplate

# SL-89

DATE	CHANGES	INTL	REV
03.12.09	Original	JB	1.00

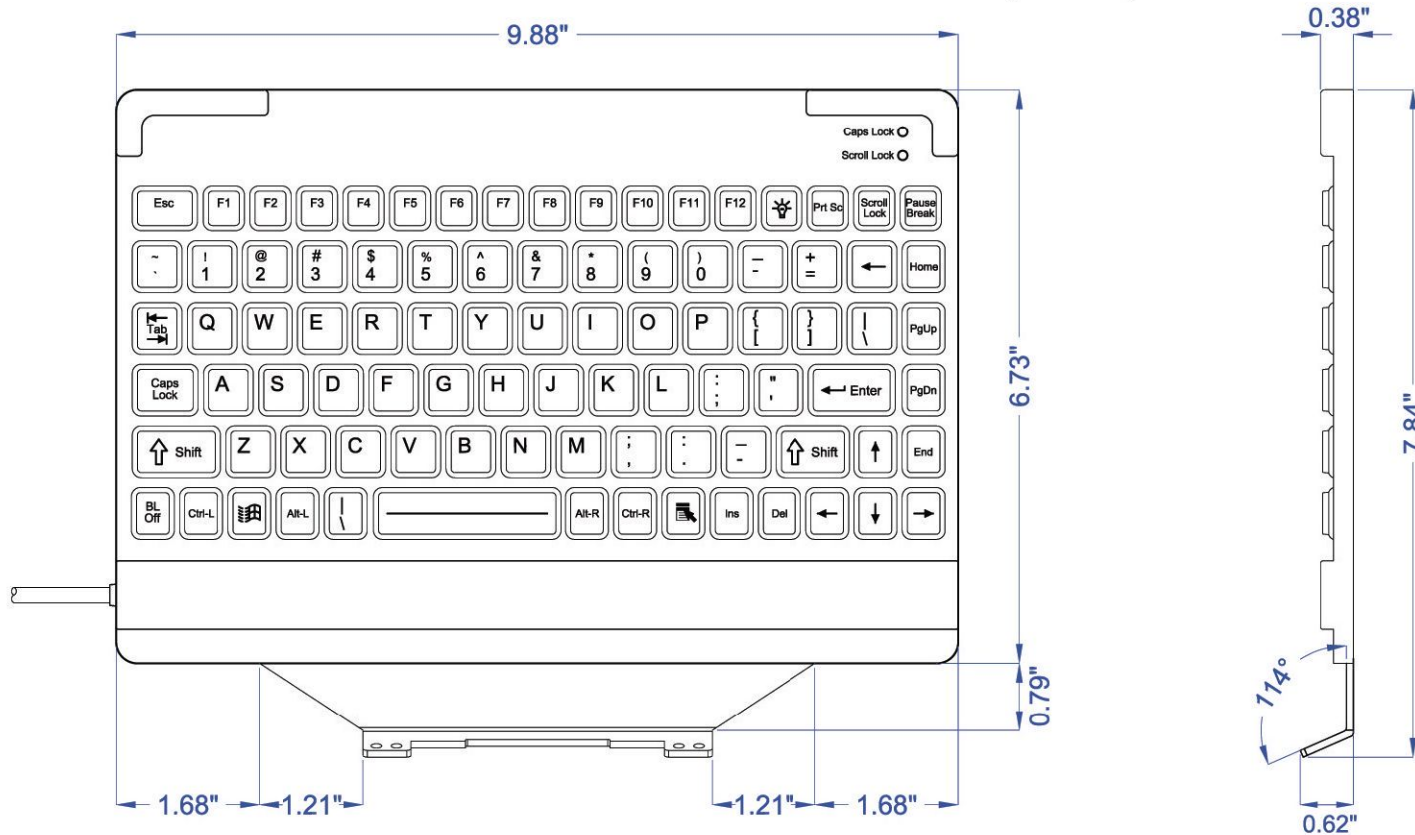

## KEY SWITCH

**MATERIAL:** Industrial Silicone Rubber  
**LIFE:** Greater Than 10 Million Cycles  
**TRAVEL:** 0.055 in.  
**ACTUATION FORCE:** 6.35 oz. +/- 1.06oz (180g +/- 30g)  
**FEEDBACK:** Tactile with Mechanical Snap

## POWER

USB: 200mA@5V (from CPU port)

## TEMPERATURE RANGE

**STORAGE:** -40°F to +194°F (-40°C to +90°C)  
**OPERATING:** -40°F to +158°F (-40°C to +70°C)

## HUMIDITY

100% Humidity Resistant

## VIBRATION

**POWER SPECTRAL DENSITY:** .04g<sup>2</sup>/HZ  
**FREQUENCY RANGE:** 20Hz-2Khz  
**DURATION OF TEST PER AXIS:** 3 hours

## SHOCK

3 X 11 ms pulses of 50g on each of 3 axis

## WEIGHT

2.00 lbs +/- 0.10 lbs (0.91 kg +/- 0.05 kg)

PROPRIETARY AND CONFIDENTIAL

SCALE: 1:2.25

Part Number: SL-89	Drawing Number: MKT0183	Sheet: 1 OF 2
Drawing Title: SL-89-MKT	Revision: 1.00	Date: 03.12.09
		JWB

# SL-89 HINGE MOUNTING HOLES DETAIL

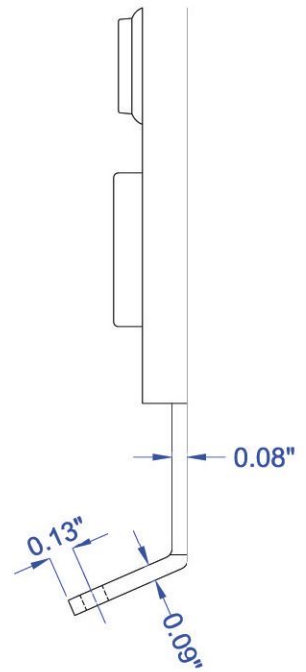
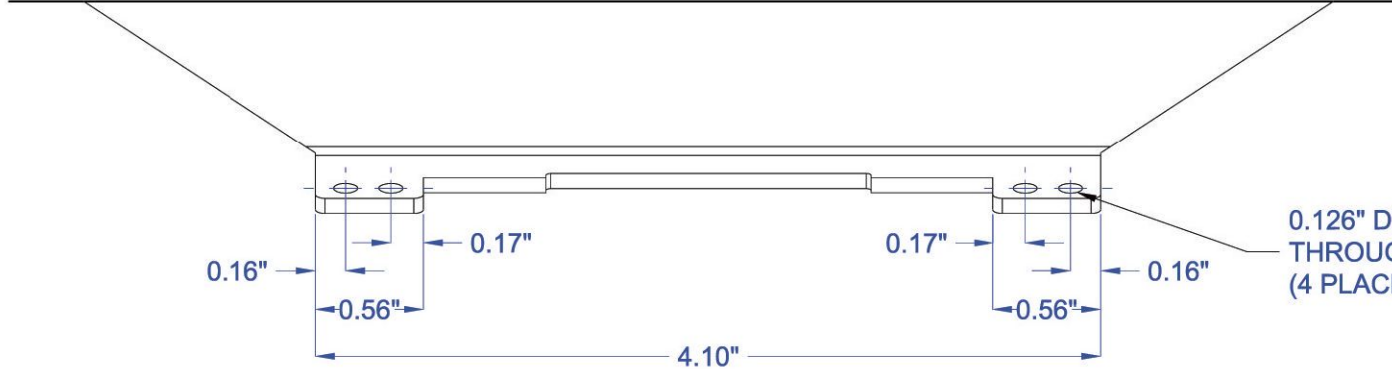
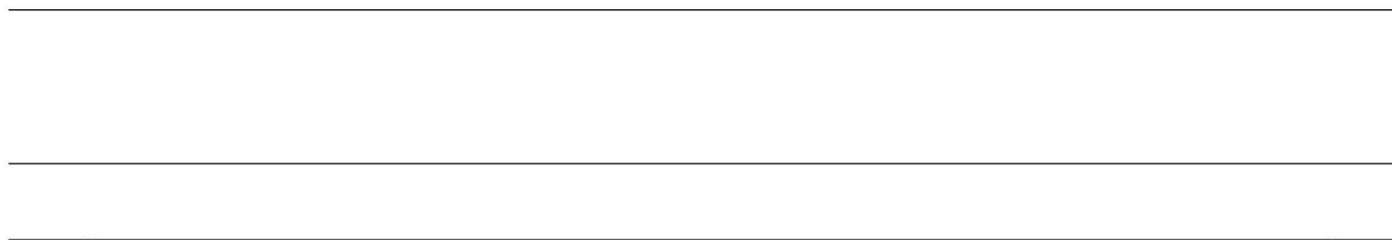
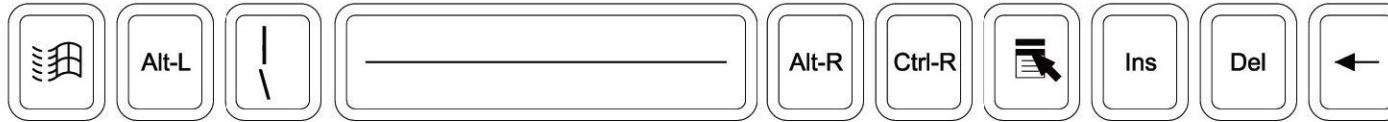

PROPRIETARY AND CONFIDENTIAL

SCALE: 1:1

	Part Number: SL-89	Drawing Number: MKT0183	Sheet: 2 OF 2	
	Drawing Title: SL-89-MKT	Revision: 1.00	Date: 03.12.09	JWB



Distributed by:  
 i-Tech Company LLC  
 TOLL FREE: (888) 483-2418 • EMAIL: [info@iTechLCD.com](mailto:info@iTechLCD.com) • WEB: [www.iTechLCD.com](http://www.iTechLCD.com)