

SLK-77-M

Compact Backlit Industrial Keyboard



The compact SLK-77-M keyboard is packed with functionality. It features a full QWERTY keyboard layout, 12 function keys, integrated mounting holes and red LED backlighting in a rugged ABS polycarbonate case measuring 9.31" x 3.88" (width-height). The SLK-77-M is designed to meet NEMA 4X specifications, with a completely sealed industrial silicone rubber keypad that can withstand the dirt, dust, water and corrosives that often exist in harsh environments. It is an excellent keyboard for material handling, mobile and industrial applications.

Technical Specifications

Certifications	NEMA 4X, CE UL60950, FCC PART 15 CLASS B
Shock	3 x 11 ms pulses of 50g on each of 3 axes
Cable	LENGTH: 3' straight (0.91 m) DESIGN: Single Cable USB
Key Switch	MATERIAL: Industrial Silicone Rubber LIFE: Greater than 10 Million Cycles TRAVEL: 0.055 in. (1.4mm) ACTUATION FORCE: 4.76 oz. +/- 1.06 oz. (135g +/- 30g) FEEDBACK: Tactile with Mechanical Snap
Vibration	POWER SPECTRAL DENSITY: .04g/HZ FREQUENCY RANGE: 20Hz - 2Khz DURATION OF TEST PER AXIS: 3 hours
Power	USB: 200mA@5V (from CPU port)
Compatability	USB: All Windows and Macintosh OS
Temperature Range	STORAGE: -40C to +90C (-40F to +194F) OPERATING: -40C to +70C (-40F to +158F)
Weight	1.00 lbs +/- 0.10 lbs (0.45 kg +/- 0.05 kg)
Warranty	1 year limited warranty
Humidity	100% Humidity Resistant
Dimensions	9.31" x 3.88" x 1.61" (w-h-d) 236.5mm x 98.6mm x 40.9mm
Model Numbers	SLK-77-M-USB

Features and Benefits

- Industrial Silicone Rubber Keypad
- Red Backlit Keys
- Ultra-Small Footprint Design
- USB configurations available

SLK-77-M

DATE	CHANGES	INTL	REV
07.22.08	Original	JB	1.0
06.24.09	Updated Nomenclature and Dimension Accuracy	JB	2.0

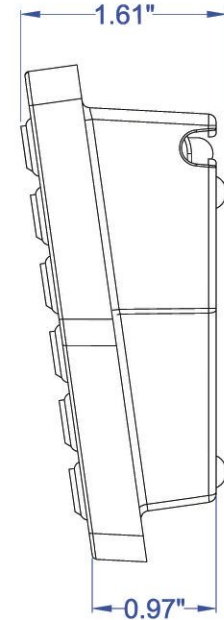
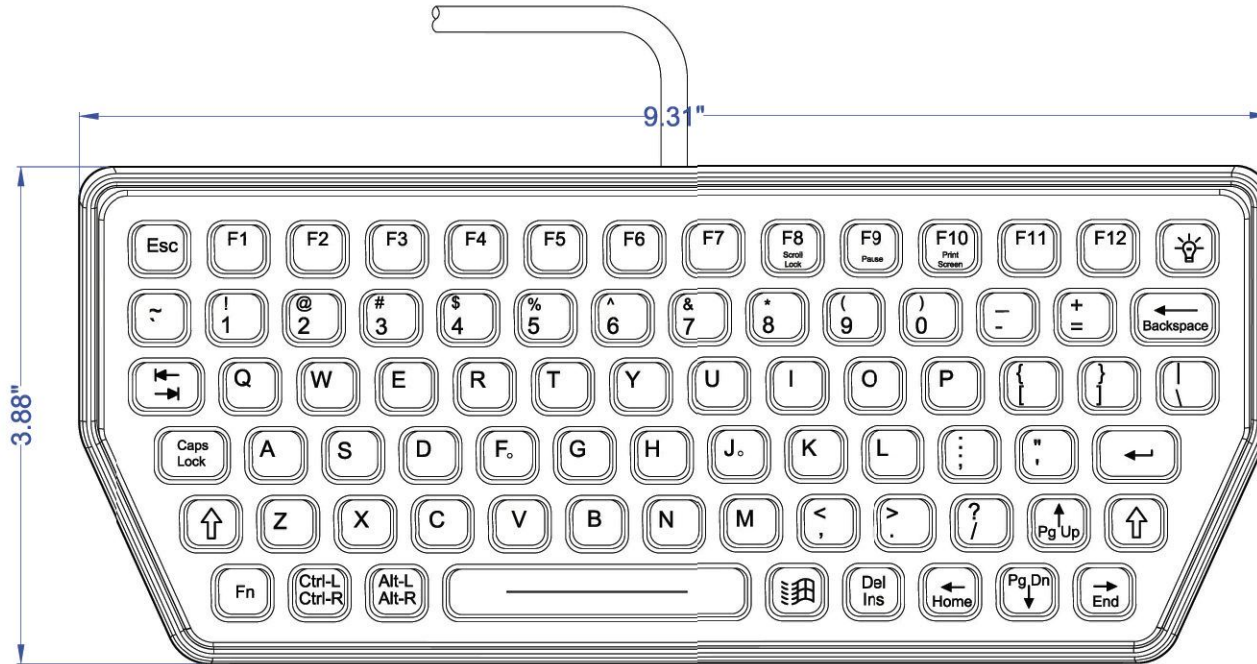

KEY SWITCH

MATERIAL: Industrial Silicone Rubber
LIFE: Greater Than 10 Million Cycles
TRAVEL: 0.055 in.
ACTUATION FORCE: 4.76 oz. +/- 1.06oz (135g +/- 30g)
FEEDBACK: Tactile with Mechanical Snap

POWER

USB: 200mA@5V (from CPU port)

TEMPERATURE RANGE

STORAGE: -40°F to +194°F (-40°C to +90°C)
OPERATING: -40°F to +158°F (-40°C to +70°C)

HUMIDITY

100% Humidity Resistant

VIBRATION

POWER SPECTRAL DENSITY: .04g²/HZ
FREQUENCY RANGE: 20Hz-2Khz
DURATION OF TEST PER AXIS: 3 hours

SHOCK

3 X 11 ms pulses of 50g on each of 3 axis

WEIGHT

1.00 lbs +/- 0.10 lbs (0.45 kg +/- 0.05 kg)

PROPRIETARY AND CONFIDENTIAL

SCALE: 1:1.5

Part Number: SLK-77-M	Drawing Number: MKT0126	Sheet: 1 OF 2
Drawing Title: SLK-77-M-MKT	Revision: 2.0	Date: 06.24.09 JWB

SLK-77-M BACK / MOUNTING

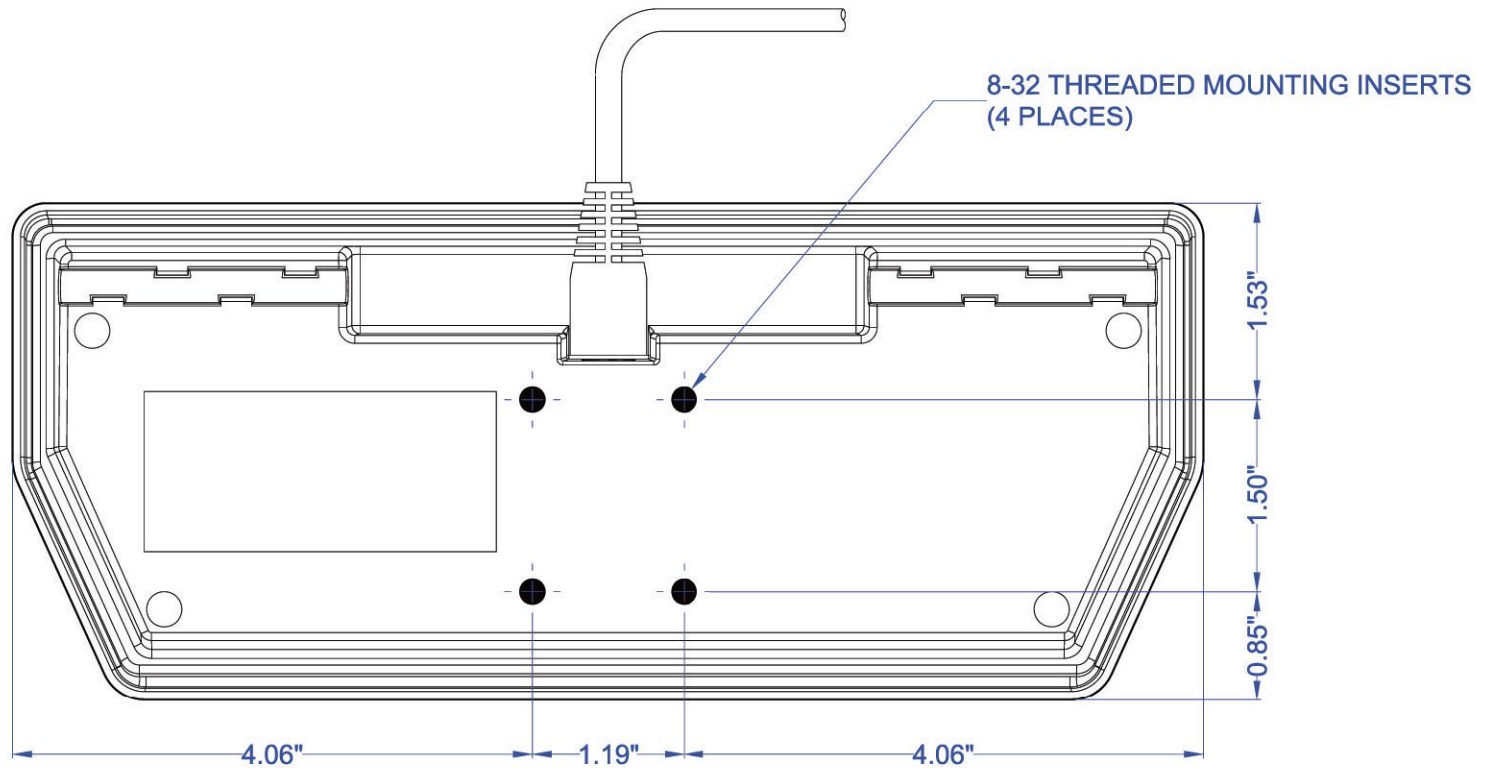

ENCLOSURE CASE: ABS/Polycarbonate

PROPRIETARY AND CONFIDENTIAL

SCALE: 1:1.5

Part Number: SLK-77-M	Drawing Number: MKT0126	Sheet: 2 OF 2	
Drawing Title: SLK-77-M-MKT	Revision: 2.0	Date: 06.24.09	JWB



Distributed by:
 i-Tech Company LLC
 TOLL FREE: (888) 483-2418 • EMAIL: info@iTechLCD.com • WEB: www.iTechLCD.com