

Industrial Fanless PANEL PC

Panel mount Resistive Front IP66
 Fanless 15" 1024x768 450 nits, 8th gen. Whisky Lake Core
 i5-8365UE, 1.6GHz, 4GB DDR4, 2.5" 500G HDD Resistive front flat
 2 Years Warranty



Model: WPC1500-i5-FTR

FEATURES:

- Intel 8th Generation Core i7/i5/i3 CPU
- 15" 1024x768 LCD 450nits
- Res or P-Cap Touch with Front IP66 Design
- Front Panel Mount Housing
- Vpro Support by CPU
- CE, FCC, VCCI Class B Passed
- Optional WLAN with External Antenna



SPECIFICATIONS:

Main System	CPU	Intel 8th Gen Whiskey Lake-U Core™ i7/i5/i3 MCP Processor, 15W
	Graphic	Intel UHD Graphics 620
	Memory	Two 2400MHz DDR4 SODIMM socket support Dual Channel, up to 32GB
	OS Support	Win 10 (64 bit)
Display	Size	15", 4:3
	Resolution (pixel)	1024 x 768 (XGA)
	Number of Colors	16.2M colors
	View Angle (H/V)	160(H) / 160(V)
	Brightness(cd/m ² , nit)	450 nits
	Contrast Ratio	800:1 (Typ)
Touch Panel	Type	Full flat resistive touch panel
	Light Transmission	80 ± 5%
	Hardness	>=3H
	Lifetime	35M times
Storage & Expansion	Storage	2.5" SATA HDD drive bay x 1 (with anti-vibration mechanism) M.2 (KEY M, 2242/2260/2280) SSD X 1
	Expansion	M.2 (Key E, 2230) for Wireless x 1, M.2 (Key B, 3042) with USB2.0 and SIM for 4G x 1
I/O Ports	USB	USB 3.1 x 4
	COM	2 X RS-232, 1 X RS-232/422/485
	LAN	2 x RJ-45
	Audio / Video	3.5mm phone jack connector x 2 (Line-out, Mic-in)/HDMI x 1, DP x 1
	Control Keys	Rear bottom: Power on /off
Power	Power input	DC19~28V input
	Power adapter	TBD (19VDC Output PSU with PSE)
Environmental	Temperature	Operating Temperature: 0~50°C (19V DC, air flow cooling) Storage Temperature: -20~65°C
	Humidity	Operating & Storage: 10 ~ 90%, non-condensing
	Water/Dust resistance	IP66 at front
Mechanical Characteristics	Housing	Front bezel is Aluminum, others are SECC with black coating
	Dimensions (Net: mm)	398 (H) x 330 (V) x 86 (T)
	Weights (Net: kg)	TBD kg
	Mounting	Panel mount, Optional Open frame / Chassis, VESA (75x75)
Certification	CE/ FCC/ VCCI Class B	

MECHANICAL DRAWING:

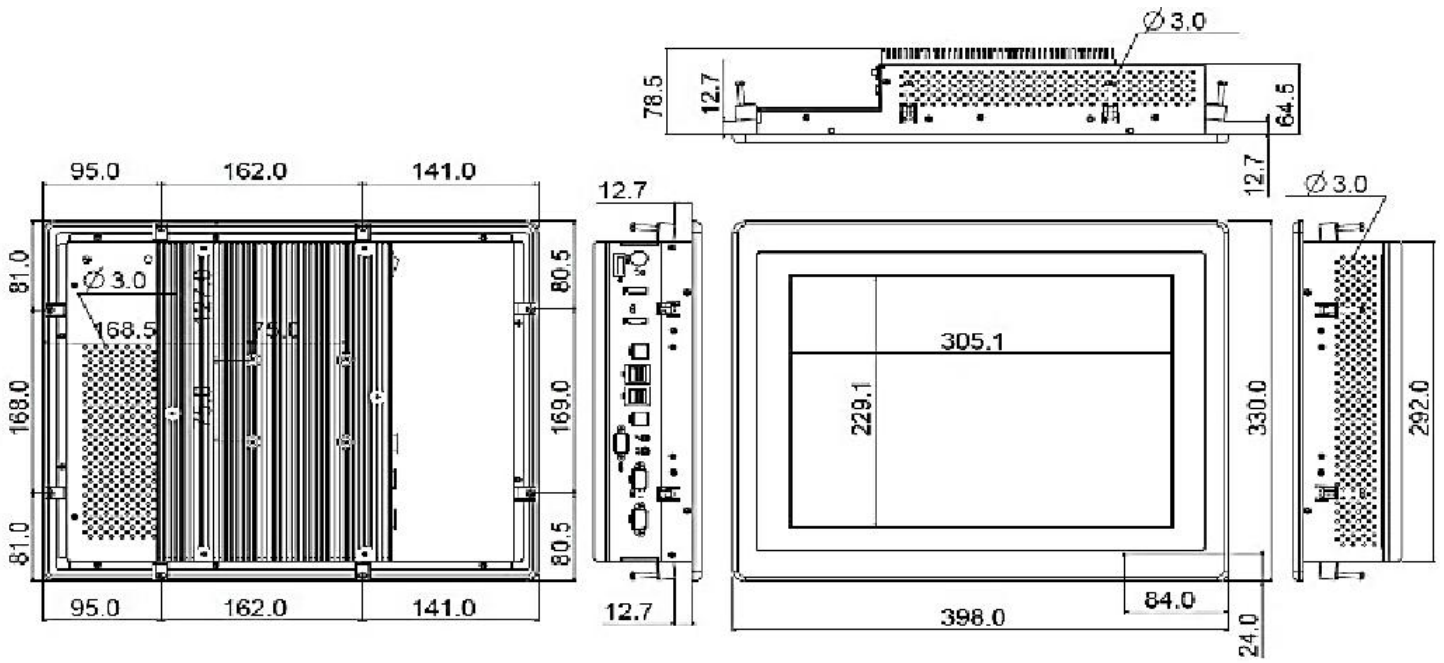

Major Options	
Add On Parts	1. Wireless and BT kit 2. 2.5" SSD or M.2 SSD 3. Stainless steel front bezel 4. Silver front bezel 5. TPM 2.0
Add On Cable	1. DC input power plug