

Fanless Full IP65/NEMA4 Panel PC Stainless Chassis

Model: WCHPC1500C3IP-AT

15" Fanless Full IP65/NEMA4 Panel PC (Intel® ATOM N270 Platform)

Mechanical Design

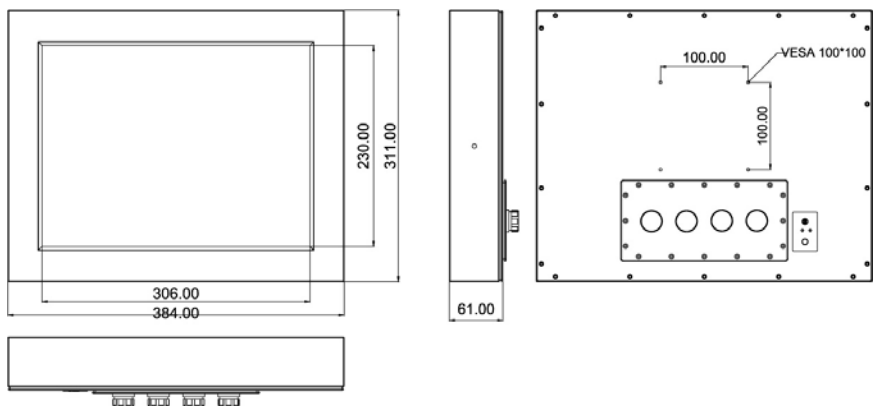

Standard:
brushed stainless



Optional:
black, high polish,
vanished coating

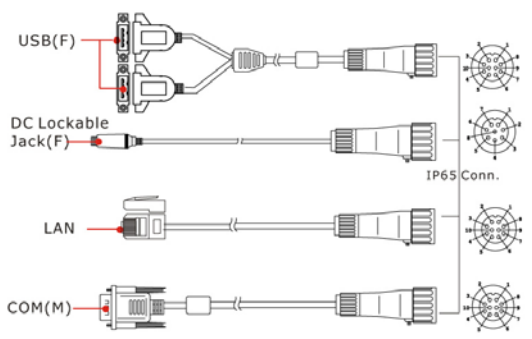

IP65 connector / cable

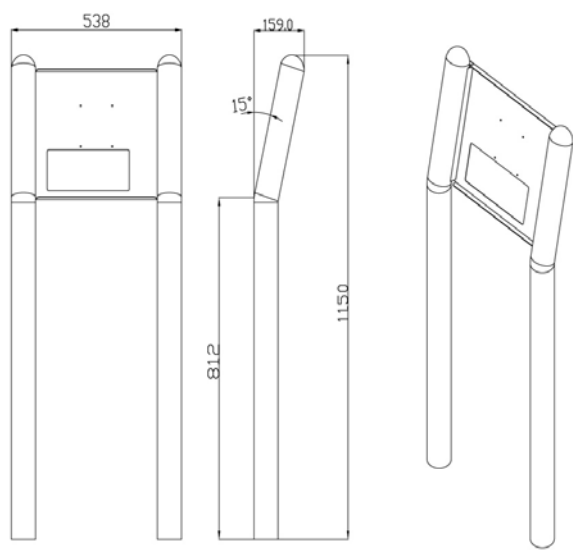

Mounting Stand
(optional)



* Note: this is a simplified drawing and some components are not marked in detail. Please contact our sales representative if you need further product information.



Fanless Full IP65/NEMA4 Panel PC Stainless Chassis



Specifications

TFT Characteristics	
Resolutions	1024 x 768
Brightness	250 cd/m (typ.)
Contrast Ratio	700 : 1 (typ.)
Viewing Angles	-70~70(H);-65~60(V)
Max Colors	16.2M

SBC Specifications:	
Processor	Intel Atom N270 1.6 GHz
BIOS	AMI 4Mbit Flash
System Chipset	Intel 945GSE / ICH7M
Memory Slot	1 x SO-DIMM, Max 2GB DDR2 400/533
Graphic Chipset	Intel 945GSE Integrated (224MB shared)
IDE	1 x 44pin IDE (UDMA 33/66/100)
KB/Mouse	1 x PS/2
Ethernet	1 x RJ45(Gigabit LAN)
Audio	Built in AC97 codec
USB	6 x USB2.0 (4 x USB internal)
Serial	2 x RS232 (1 x RS232 internal)
Expansion Slot	1 x Mini PCI (internal)
SSD Interface	1 x Type I/II CF socket (Internal)
Power Input	DC-IN (Lockable, Power Jack)
Certification	CE, FCC, RoHS
A customized housing is needed if you would like to have the PCI expansion.	

Note: All Specifications are subject to change without prior notice!

Power Specifications:	
Power Input	12V DC IN (Lockable Power Jack)
Power Consumption	20W (typ.)(Max.backlight & high CPU load)

Accessories:	
External Power Supply 90W w/power cord	

Environment Considerations :	
Operating Temperature	0 deg.C to 45deg.C
Operating Humidity	30% to 90% (non condensing)

Input/ Output Connectors :	
Ethernet LAN	1 X RJ45-10/100 Mbps
COM	1 X RS232
USB	2 x USB Type-A Receptacle
Power	1 X 12VDC

Order Options :			
SBC	PANEL PC		
RAM	512 MB DDR(Optional) 1 GB DDR(Optional)	Mechanical	Stainless Chassis
Storage	2.5"80 GB HDD* 1 GB Compact Flash(Optional)	Touch	5 Wires Resistive(Optional)
* Default		OS	Windows XPE(Optional) Windows XP (Optional) Linux(Optional)
Mounting Stand			

