

10.4" Marine Panel PC



Model no.:
WMARC1040M2-AT

Mechanical and Environmental

Mechanical Mounting : Panel (Flush) mount with IP65*, VESA Bracket mounting
 Operating Temperature : -10 to 55 deg.C(-20 to 60 deg.C for optional heating)
 Operating Humidity : 5% to 95% (non condensing)
 Anti-Vibration : 5Hz~500Hz / IGrms/3 Axis
 Anti-Shock : 15G, 11ms duration
 *SAW touch for IP54

SBC Specifications

Processor : Intel Atom N270 1.6 GHz
 BIOS : AMI 4Mbit
 System Chipset : Intel 945GSE/ICH7M
 Memory Slot : 1 x240-pin DDR2 DIM, max 2GB
 Graphic Chipset : Intel 945GSE integrated (224MB shared)
 IDE : 1 x IDE (UDMA33/66/100)
 Compact Flash : 1 x Type I/II CF Socket (Optional)
 KB / Mouse Connector : 2 x PS/2
 Ethernet : Dual Realtek RTL8111B Gigabyte Ethernet
 VGA : 1 x VGA Connector
 Audio : Built-in Audio + AC97 Codec
 USB Ports : 8 x USB (4x USB on backside I/O)
 Serial Ports : 3 x RS232, (1 is optional), 1 x RS232/422/485
 Hard Drive : 2.5" 80GB
 Expansion slot : 1 x PCI, 1 x Mini PCI

Input/Output Connectors

Ethernet LAN : 2 x RJ45-10/100/1000 Mbps
 Keyboard / Mouse : 2 x PS/2
 COM : 2 x RS232, 1 x RS232/422/485 9P DSUB(male)
 USB : 4 x USB Type-A receptable
 RGB Out : 1 x VGA (female)
 Audio : 1 x Audio Jack (Line-out, Line-in, Micro In)
 DC Power : 1 x DC Terminal block

Available Options

Touch Screen Options : SAW, 5 Wire Resistive
 AR Safety Glass Option : 3mm Anti-reflective protection glass
 Transflective Options : Yes (Enhance Visibility)
 Bracket and Stand Options : Yes (One robust bracket can adjust from -10 to 30 deg.)

Certifications and Approvals

- CE, FCC

Power Specification

Power Supply Options : 9 to 36 V DC to DC power supply w/ Terminals Block (Default)
 Power Consumption : 65 W typical, normal operation

TFT Characteristics

Pixel Number : 800 x 600
 Pixel Pitch(R&B) : 0.240 (H) x 0.240 (V) mm
 Contrast Ratio : 500:1(typ.)
 Light Intensity : 400 cd/m2 (typ.)
 Viewable Angle : -70~70 (H);-60~50 (V)
 Active Display Area : 211.2 (H) x 158.4 (V) mm
 Max Colors : 16.7M (8bit/colors)

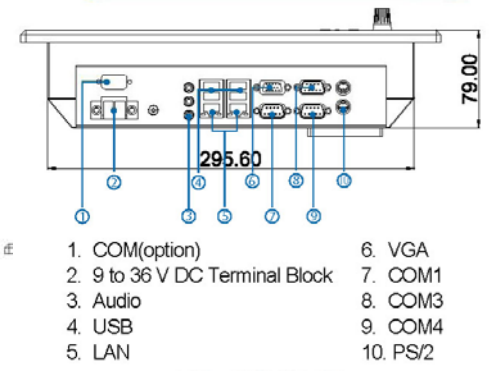
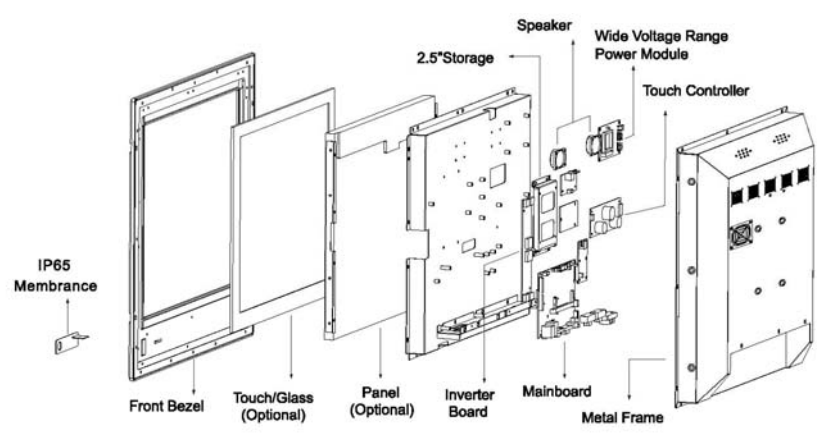

Modularized Construction

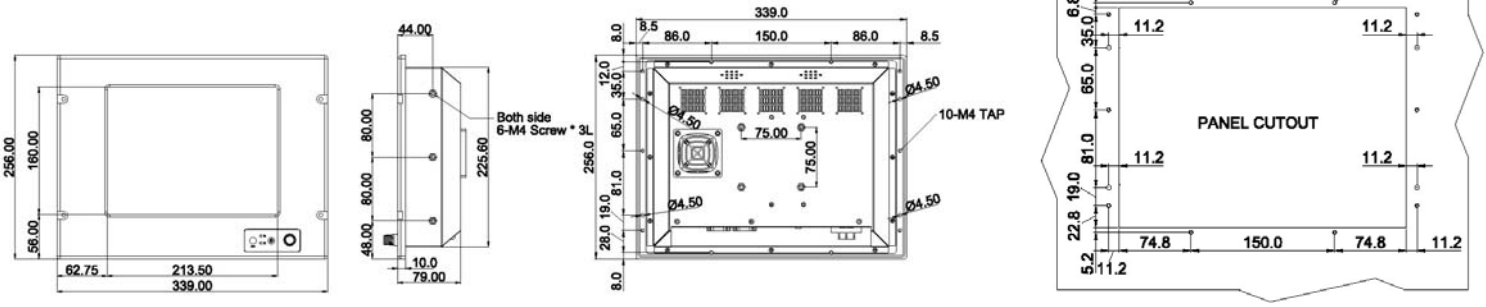

All Dimensions are ±0.5mm

10.4" Marine Panel PC

Mechanical Design with Robust Bracket (Options)

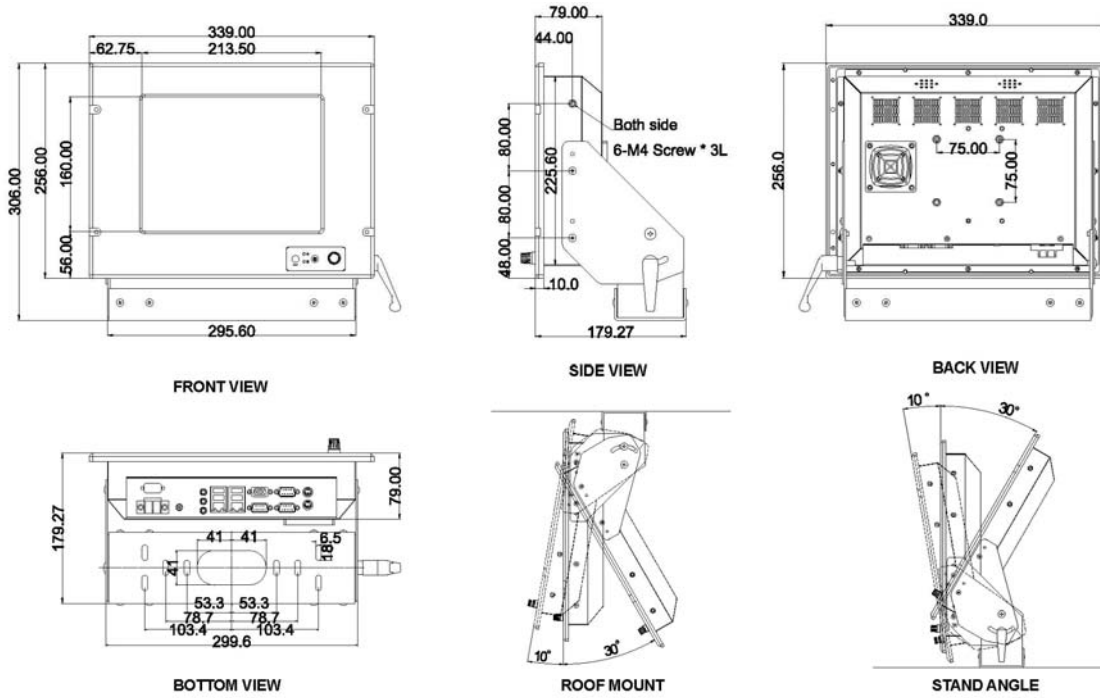

Roof Mount

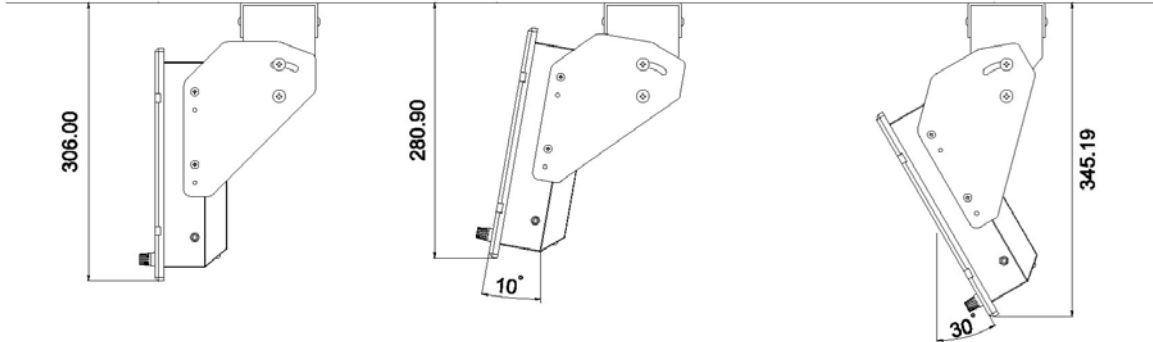

Stand Angle

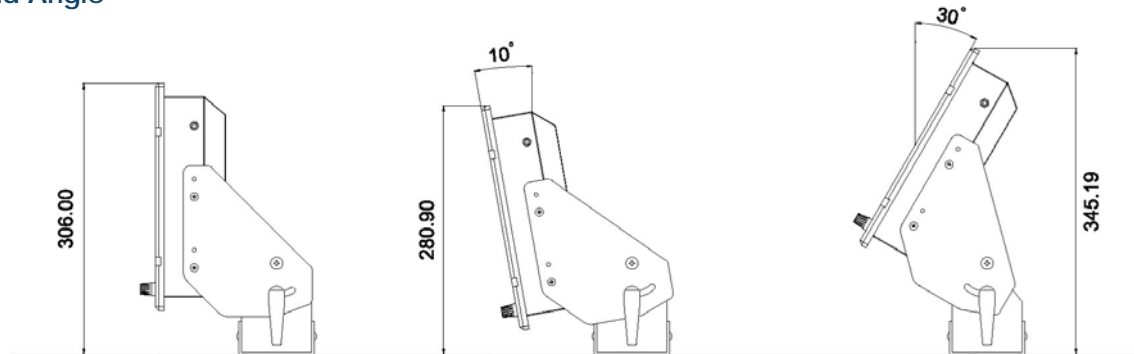

★ Note: this is a simplified drawing and some components are not marked in detail. Please contact our sales representative if you need further product information.

Certification and Approvals : CE, FCC

All Dimensions are $\pm 0.5\text{mm}$



i-Tech Company LLC
 TOLL FREE: (888) 483-2418 • EMAIL: info@itechlcd.com • WEB: www.iTechLCD.com