

FULL IP67 PANEL PC

15" Rugged Full IP67 Panel PC, 1024x768, 300nits
Intel i5-7200U 2.5 GHz w/ Aluminum Die-Casting Housing,
VESA mount and Resistive Touch

Model: WRDPC1500-i5-TR



FEATURES:

- 7 Generation Intel® Core™ i5-7200U (kaby Lake) 2.5GHz (turbo to 3.1GHz)
- High Quality 15" Panel, 1024 x 768 resolution, 300 nits (Optional for 1000 nits)
- IP67 Dust/ Water proof design with VESA mount
- Aluminum Die-Casting Housing with Anti-Corrosion Treatments
- Build in ambient Light sensor
- Wide Range 9 to 36V DC Input with isolation
- Optional 6-60V DC Input, and Optional for Ignition On/Off delay
- 5 Wire Resistive Touch / Anti-Reflective Protection Glass (Optional)
- Optional HB/Sunlight Readable up to 1000 nits

SPECIFICATIONS

DISPLAY			
Resolution	1024x768	Size	15.0 inches
Contrast Ratio	2000:1	Panel Brightness	300 nits
View Angles	88,88,88,88		
Touch / Glass	Resistive Touch Screen Bonding With Panel Protection Glass Without touch function (Optional)	Optional function	High brightness Panel for sunlight readable (Optional)
SYSTEM SPECIFICATIONS			
Processor	Intel® Core™ i57200U (3M Cache, up to 3.10 GHz) Intel® Core™ i57300U (3M Cache, up to 3.50 GHz)	Memory	1 x SODIMM, DDR3L 1600 MHz, 4GB 8GB (Optional), 16GB (Optional)
Storage	1 x mSATA SSD 64GB. mSATA SSD up to 512GB. (Optional)	Ethernet controller	Intel® Ethernet Controller I211AT + Intel® Ethernet Connection I219LM
Security	TPM 2.0	Operating System	Windows 10 IoT Enterprise (Optional) Linux Ubuntu 18.04 (Optional)
WLAN	802.11 a/b/g/n/ac (Optional)	BT	BT Support (Optional)
ENVIRONMENT			
Operating Humidity	10% to 95% RH	Operating Temperature	-15°C ~ 55°C
Storage Temperature	-30°C ~ 70°C	Shock	30g for 18ms, 300m/s ²
Vibration	1.60/1.96/2.18 g rms for XYZ / 5500Hz	IP rating	IP67
CERTIFICATION			
Certification	CE, FCC Class B MIL810F/ IEC60068227 For Vibration /Shock		
IO PORTS			
USB Port	1 x M12 waterproof connector for 2 x USB2.0	Serial Port	1 x M12 waterproof connector for RS232
Indicator	1 x LED Indicator for power 1 x LED Indicator for storage	LAN	1 x waterproof Giga LAN RJ45 connector

***Specifications subject to change without notice, not responsible for typographical errors.**

MECHANICAL			
Dimension	398 x 308 x 58 mm	Mounting	VESA Mount / Yoke Mount
Enclosure	Aluminum Housing	Cooling System	Fanless Design
CONTROL			
Button	1 x Power Button 1 x Reset Button 1 x Lock / Unlock front key function button 1 x Auto Dimming / Manually button 1 x Day / Night Mode button 1 x Brightness Up button 1 x Brightness Down button 1 x LED indicator brightness adjustment button 1 x Light sensor		
ACCESSORIES			
Accessory	External open wire Power cable with waterproof connector External USB cable with waterproof connector External COM cable with waterproof connector External LAN cable with waterproof connector Waterproof caps RJ45 female-female converter Driver CD & Manual VESA screws	Optional Accessory	Yoke mount stand (Optional) 100~240V AC to DC Adapter with power cord (Optional)

MECHANICAL DRAWINGS UNIT: MM

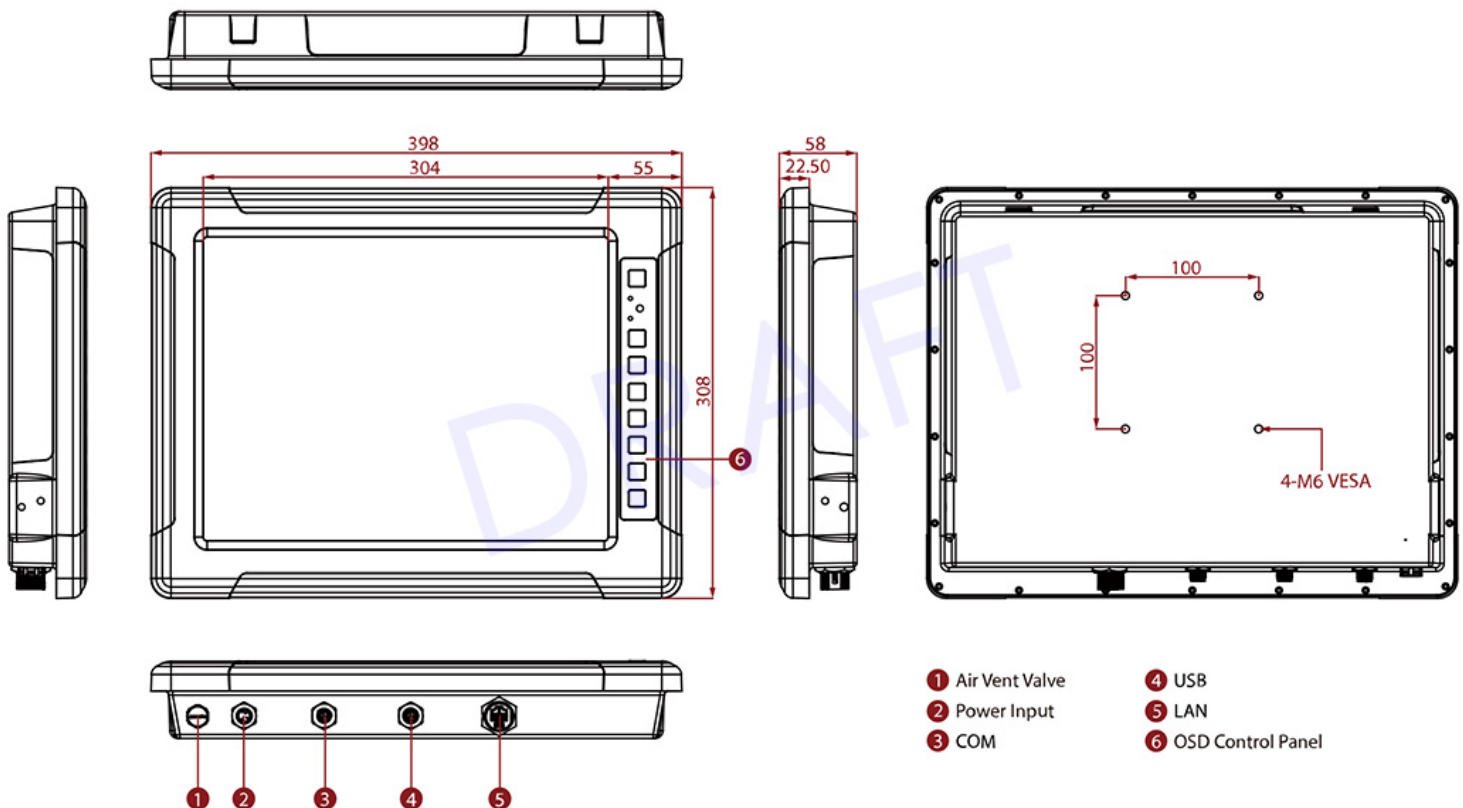

This is subject to change without Notice. Final Drawings Will be Provided for Approval after Order.