

Medical Panel PC

Wireless LAN

Web Camera

Fanless Medical Grade All-in-one 21.5" / 5wire resistive / Full Flat / Full HD 1920 x 1080/ 250 nits, Intel Panel PC, Intel Core i5-3210M 1.7GHz (Dual Core, 3MB cache), 4GB Memory, 320 GB HD, CF, Resistive Touch, FCC-B, cUL, CE, VCCI Medical 60601-1 3rd edition (EN 60601-1:2006, ANSI/AAMI ES60601-1:2005, CAN/CSA C22.2 No. 60601-1:08)

(Model: WMPC-2150i5)



Features:

- 21.5" Intel Core i Fanless Medical Panel PC
- 21.5" FHD 1920x1080 LED Panel
- Intel 3rd gen. IVY bridge Core i7/i5 CPU
- Front flat resistive touch screen
- Medical UL60601-1 3rd edition certification
- Anti-bacteria (MRSA) plastic housing
- Optional PCI/PCIe expansion slot
- Seamless in front & ultra slim 65mm only
- Easy wipe surface with no internal corner
- IP65 at front side, IPx1 for whole system
- Friendly design of Function hot-deys
- Optional 4KV LAN/COM/USB isolation I/O
- Optional built-in battery pack
- Optional P-CAP (4-fingers) touch

System

CPU	FCBGA1023 3rd Generation Intel® Core i5 processor (17W max.)
Chipset	Intel BD82HM65 PCH
Graphics	Intel HD Graphics HD 4000
Memory	Two 1066/1333/1600 MHz DDR3 SODIMM socket support dual Channel, non-ECC, up to 16GB
Serial ATA	SATA 3, 600 MB/s transfer rate x 2
USB	•External USB 2.0 x 4 (Type A) •Internal 3.3V Socket x 3, 5V Pin Head x 2
COM	x 6 (RS232, 422, 485 x 1 / RS232 x 5)
Audio	Realtek ALC262 audio codec, 2+2 watts amplifier
LAN	Marvell 88E8071 Gigabit Ethernet x 2
Speaker	1.5W x 2
WDT	Generates system reset; 256 segments, 0, 1, 2...255 sec/min AMI BIOS, 4M EEPROM •Brand: AMI BIOS
BIOS	•Flash ROM size: 64M bit •Support RTC wakeup /Wake on LAN /Power on after power failure/PnP/ACPI/RTC

LCD Panel

Size	21.5" wide 16:9
Resolution	Full HD 1920 x 1080
Brightness	250 nits
Contrast	1000:1
Color numbers	16.7M (6-bit x 3 + Hi FRC)
Viewing angle	170 (H) / 160 (V)
Response time	5 ms (Typ)
Backlight	LED, 30,000 hours life time

Touch Panel

Type	Front full flat touch panel
Technology	5-wire resistive touch (default)
Transparency	> 78% (at 550 nm wavelength)
Hardness	3H
Durability	Knock 35 million times

Storage & Expansion

HDD	2.5" SATA HDD drive bay x 1 + anti-vibration kit, 320GB / 500GB
-----	---

Expansion slot

- PCI-E x 16 expansion slot x 1 (60W max, can't co-exist with isolated module) or PCI 2.2 x 1 (by different configuration)
- Card size: 68mm (W) x 220mm (D) x 18mm(H)
- Mini PCIe x 2 (52 pin card-edge type)

I/O & Control Keys

USB	USB 2.0 x 4
COM	DB-9 x 2 (RS232, RS232/422/485<w/ auto flow control>)
LAN	RJ-45 x 2, Gigabit
Video-out	DVI-I x 1
Audio	Line-out, Microphone-in (3.5 mm phone-jack)
Power input	DC-in x 1, 7V~32V •Front side, projected capacitive type
Control keys	•Power on/off, Brightness, Audio volume, Backlight on/off, Touch on/off

Power

Power adaptor	External, 100 watts, 90~264V AC in, 12V DC out, medical grade, 1.2m DC cable
Power consumption	42.624 watts (MAX. loading without adapter) •Lithium-Ion, 28Wh, for 25 minutes operating (approx.), 2S2P •Charge time: 2 hours (system off), 3.5 hours (system on)

Internal battery (optional)

Mechanical and Environmental

Housing	Front: Full flat design / Touch (standard), Glass (optional), Rear: Plastic + I/O cover w/ antibacterial treatment □
Color	Housing: White, Control key icons: Grey (Panton no. Cool grey 8C)
IP Rating	IP65 – front side
Cooling	Fanless w/ back cover aluminum thermal plate
Mounting	VESA 75 x 75 / 100 x 100 mm
Kensington lock	Yes, bottom x 1
Dimension	540 x 375 x 78 mm (W x H x D, w/o stand)
Weight (net)	7.0 Kg (approximate, w/o power adaptor)
Temperature	. Operating : 0°C~40°C (chamber) . Storage : -20°C~60°C
Humidity	Operating & storage – 10%~90%, non-condensing .FCC-B, cUL, CE, VCCI
Regulatory	.Medical 60601-1 3rd edition (EN 60601-1:2006, ANSI/AAMI, ES60601-1:2005, CAN/CSA C22.2 No. 60601-1:08)



I/O Connectors:

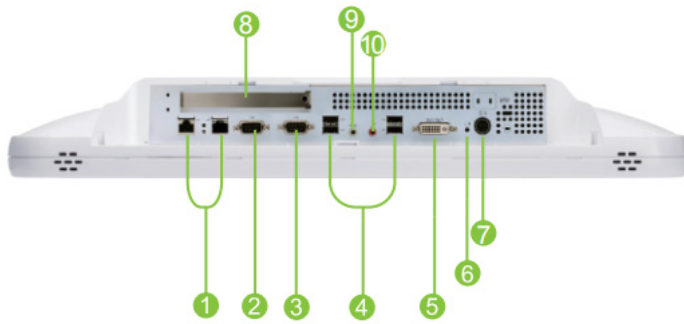

- | | |
|-----------------|-----------------------|
| ① LAN x 2 | ⑥ Reset |
| ② RS232/422/485 | ⑦ DC-in |
| ③ RS232 | ⑧ PCI-E/PCI expansion |
| ④ USB x 4 | ⑨ Line-out |
| ⑤ DVI-I | ⑩ Microphone-in |

Mechanical Drawings:

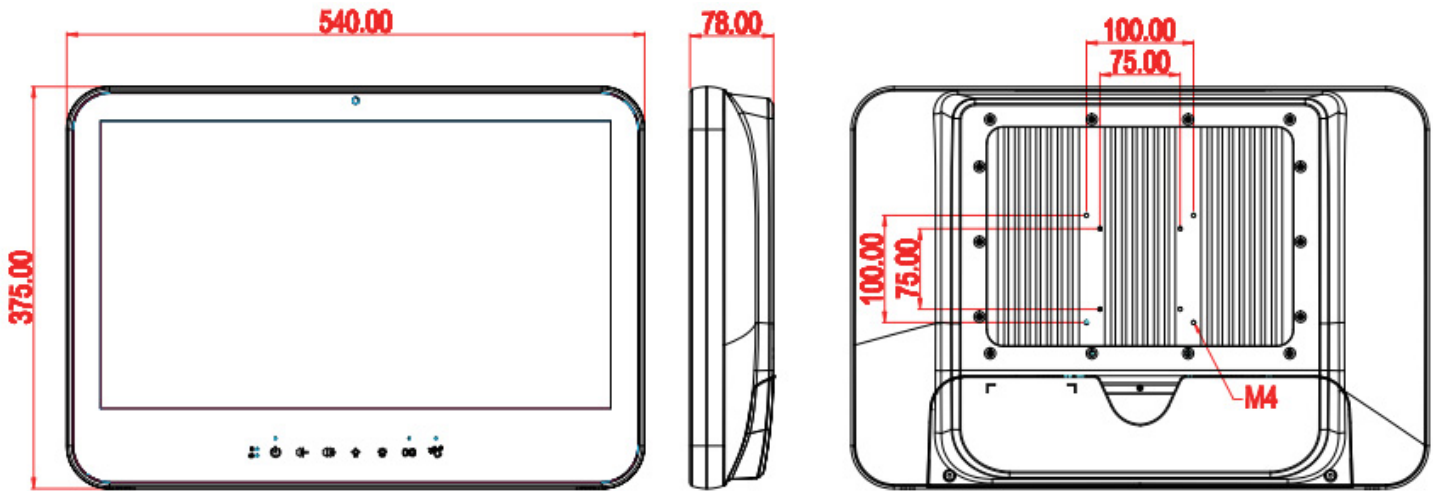

Packaging / Options / Customization

Packaging

System, power adaptor, AC power cord, DVD (drivers & manual)

Options

- WLAN 802.11 a/b/g/n mini PCIe module with internal antenna x 2
- 802.11a/b/g/n dual-band 2T2R with Bluetooth
- Webcam (3.2M pixel, USB)
- 28W battery pack
- RFID (13.56Hz) (5V USB)
- PCI-E x16 or PCI riser card
- Power adaptor w/ 2.4m or 3.6m DC cable
- PoE card (PCI-E x 4)
- Equipotential terminal pin
- Anti-bacteria desktop stand (metal, white)
- Microphone on I/O cover
- AG Film
- Projected capacitive multi-touch

Customization

- 4KV Isolation Card x 1
(Isolation COM x 2, Isolation LAN x 1, Isolation USB x 1)
- Add extra two COM ports
- Tempered glass
- TPM 1.2 module
- 2D Barcode scanner
- High Speed USB 3.0 x 2

