

# Industrial Fanless PANEL PC

Fanless 10.4" LCD Industrial Panel Resistive-type Touch Screen PC Resolution  
800 x 600, 230 nits Fanless Panel PC Intel Celeron J1900 2.0 GHz quad-core  
processor 10W w/ Atom D525-1.8GHz CPU w/ 500 GB HDD w/ 2G RAM w/ PCAP Touch Panel  
CE, FCC, VCCI Class B Certified



**Model: WPC1000V2-PCAP-B-V2**

## FEATURES:

- Intel Bay Trail Fanless & Slim Panel PC
- 10" 800x600 (SVGA) LCD 230nits
- Low power and true fanless thermal solution
- Panel Mounted w/Full Flat Resis. or P-Cap Touch
- CE, FCC, VCCI Class B Certified
- Full Flat Design Easy Clean & IP66 Front
- Wide Range DC Input
- Optional WLAN with External Antenna

## SPECIFICATIONS:

<b>Main System</b>	CPU	Intel Celeron J1900 2.0 GHz quad-core processor 10W
	Graphic	Intel® integrated HD Graphics
	Memory	two DDR3L SODIMM socket support up to 8GB
	OS Support	Win 7pro, Win 8, Win 8.1 industrial, Win 10
<b>Display</b>	Size	10", 4:3
	Resolution (pixel)	800 x 600 (SVGA)
	Number of Colors	262K, LVDS 6-bits
	View Angle (H/V)	130(H) / 110(V)
	Brightness(cd/m <sup>2</sup> , nit)	230 nits
Contrast Ratio	400:1 (Typ)	
<b>Touch Panel</b>	Type	Projected capacitive touch panel
	Light Transmission	90 ± 3%
	Hardness	7H
	Lifetime	100M times
<b>Storage &amp; Expansion</b>	Storage	2.5" SATA HDD up to 320 / 500GB w/Anti-Vibration Kit
	Expansion	Mini PCIe x 2
<b>I/O Ports</b>	USB	USB 3.0 x 1, USB 2.0 x 3
	COM	2 X RS-232, 1 X RS-232/422/485
	LAN	2 x RJ-45
	Audio / Video	3.5mm phone jack connector x 2 ( Line-out, Mic-in) / DVI-I x 1
	Control Keys	Rear bottom: Power on /off
<b>Power</b>	Power input	DC-in x 1 , 7 ~ 32V
	Power adapter	AC 90 ~ 264V / 47 ~ 63 Hz / DC output 12V
<b>Environmental</b>	Temperature	Operating Temperature: 0~50°C (12V DC , air flow cooling) Storage Temperature: -20~60°C
	Humidity	Operating & Storage: 10 ~ 90%, non-condensing
	Water/Dust resistance	IP66 at front
<b>Mechanical Characteristics</b>	Housing	Front bezel is Aluminum, others are SECC with black coating
	Dimensions (Net: mm)	313 (H) x 240 (V) x 48.5 (T)
	Weights (Net: kg))	3.5 kg
	Mounting	Panel mount, Optional Open frame / Chassis, VESA (75x75)
<b>Certification</b>	CE/ FCC/ VCCI Class B	

**MECHANICAL DRAWING:**

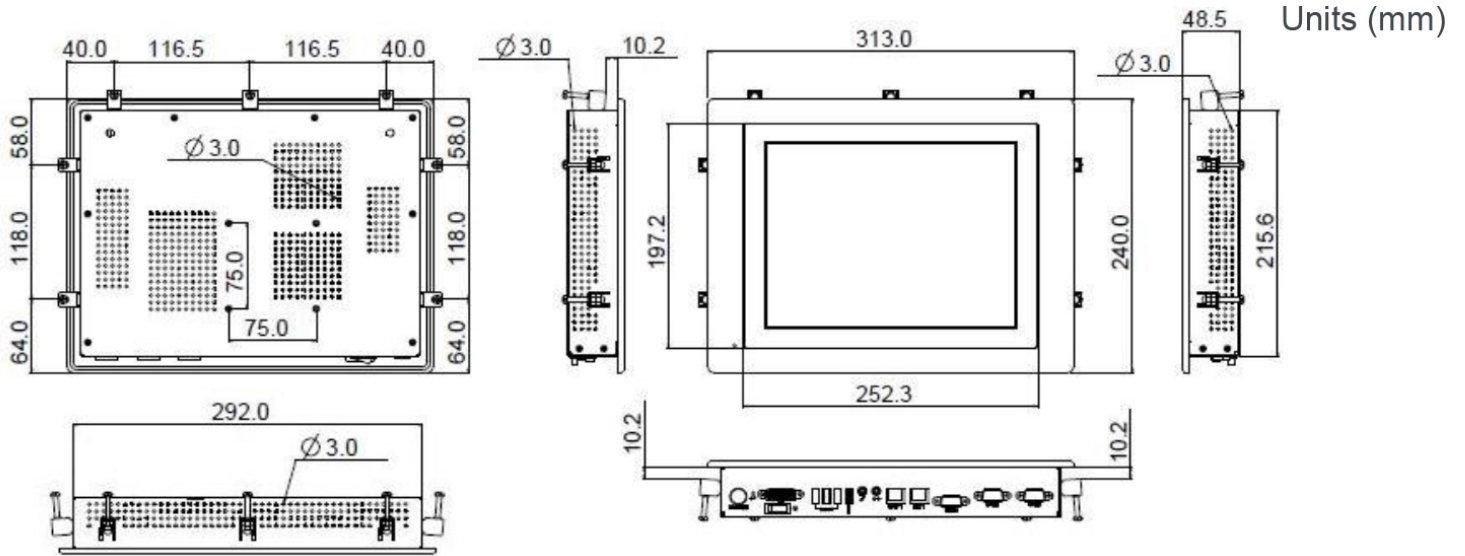

<b>Major Options</b>	
Add On Parts	1. Wireless or Wireless + BT kit , 2. Stainless front bezel, 3. Silver front bezel, 4. TPM 2.0, 5. Chassis type housing, 6. 2.5" SSD, 7. P-cap touch (BKPT)
Add On Cable	1. DC input power plug (black, 1.22m length)
Customized	1. Open frame housing, 2. Sunlight readable optical bonding, 3. LCD auto dimming, 4. LCD super dimming (Low brightness), 5. Storage door Solution

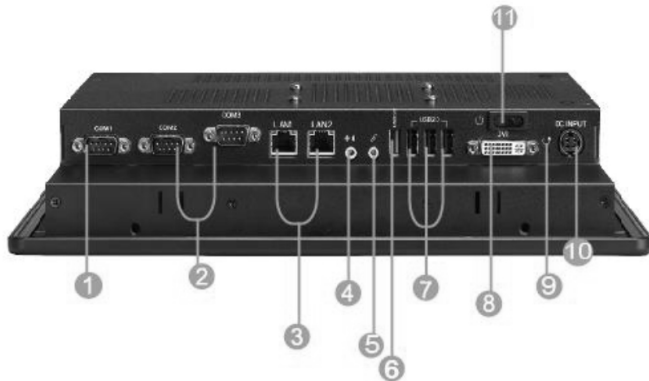

- ① RS232/422/485
- ② RS232 x 2
- ③ LAN x 2
- ④ Line out
- ⑤ Microphone-in
- ⑥ USB 3.0
- ⑦ USB 2.0 x 3
- ⑧ DVI-I output
- ⑨ Reset
- ⑩ DC-in
- ⑪ Power on/off



Stainless Steel Front Bezel (Option)