

World Leader • In-Rack • Audio & Video Monitoring

WOHLER AMP1A-LP4S

Compact, High Quality Analog Self-Powered Speaker System - 4 Stereo Channels

January 15, 2004



Typical AMP1 Frequency Curve (1/6 octave)

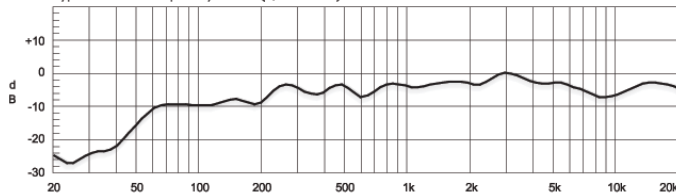

Features:

- Full Fidelity Audio Monitoring in only 1U of rack space
- 8 Balanced Analog Inputs (4 Stereo, Select 1)
- Balanced Analog Output of Selected Stereo Source
- Powerful 98dB SPL at 2 feet (0.6m)
- Two 10 Segment Tri-Color Level Meters Displaying VU or PPM
- Premium Quality Drivers & Power Amplifiers
- Extended Frequency Response and Low Distortion
- Focused Sound, Reduces Adjacent Bay Crosstalk
- Audible Indication of Phase/Polarity Problems
- Innovative LED Display of Phase/Polarity Relationships
- Thorough Magnetic Shielding for Placement next to Video Monitors
- Headphone Jack, Mutes Speakers
- Blowout Proof Speakers
- Quick and Simple Installation

The AMP1A-LP4S provides self-powered, full-fidelity stereo audio monitoring in the smallest rack space possible. A front panel switch allows the operator to select one stereo source for monitoring & output from up to 4 stereo analog inputs (8 channels). The AMP1A-LP4S features two 10 segment LED level meters showing VU or PPM for accurate level-metering. This unit contains four high performance transducers driven by three power amplifiers: one amplifier/driver combination handles midrange and high frequency information in stereo, while the second handles summed low frequency information below the 500 Hz crossover point..

The unique design provides optimally focused sound for operators in an Ultra Near Field (1 to 3 ft.) working environment and offers performance comparable to that of many separate monitor pairs, yet does so without the installation hassles, awkward speaker placements and "added-on" look. This provides for a higher SPL for the operator while reducing overall ambient sound and adjacent bay crosstalk.

Extended HF response reveals potential problems with audio whine or hiss and electronic rather than acoustic cancellation of bass frequencies provides positive audible detection of out-of-phase (reversed polarity) audio feeds. A headphone jack is provided on the front panel, usage automatically mutes the speakers. The front panel features an innovative LED Display of Phase/Polarity Relationships. Output limiter circuits are incorporated to protect the speakers, and extensive magnetic shielding allows placement immediately adjacent to video monitors with no color impurities.

The AMP1A-LP4S is ideally suited for use in VTR bays, mobile production vehicles, teleconferencing installations, multimedia systems, satellite link and cable TV facilities, and on-air radio studios. Built and rigorously tested in the USA, the AMP1A-LP4S is backed by a strong warranty and a "Satisfaction Guaranteed" return policy.

**I-TECH
COMPANY**
www.i-techcompany.com
Toll Free: 1-888-483-2418
USA: 1-510-429-9288
Fax: 1-510-372-2736

Audio Monitoring

Level Metering

Alarm Systems

Video Monitoring

Wohler

WOHLER AMP1A-LP4S

Compact, High Quality Analog Self-Powered Speaker System - 4 Stereo Channels

Rear Panel:

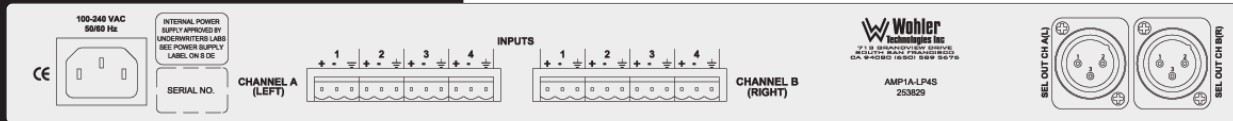

System Diagram:

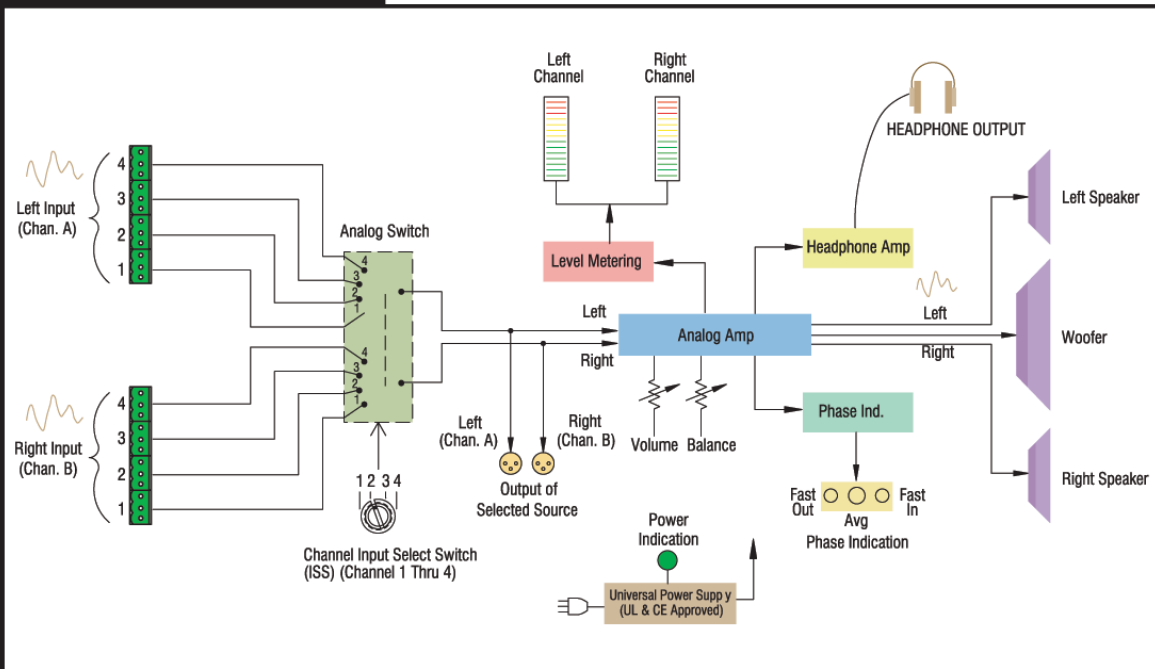

Specifications:

Input	4 stereo balanced analog - phoenix terminals
Output	balanced analog output of selected pair - XLR
Level meters	2 x 10 segment bargraphs
Level meter scale	+3 to -20 dB
Level meter threshold	-6, 0, +4, +8 dBv: DIP switch selectable
Level meter dynamics	VU or PPM: DIP switch selectable
Midscale resolution	1 dB
Analog input impedance	>40 kOhms balanced
Peak acoustic output @ 2 feet	98dB SPL
Frequency response (1/6 octave)	.80Hz - 20kHz (± 5 dB) (-10dB @ 50Hz, 22kHz)
Power output	RMS each side (2 Ohms) - 5W, 7W peak RMS dual WOOFER (4 Ohms) - 11W, 16W peak
Electrical distortion	<0.15% at any level below limit threshold
Acoustic distortion	.8% or less worst case frequencies above 180Hz including cabinet resonance, typically <2%
Hum and noise	better than -68dB below full output
Magnetic shielding	<0.5 gauss any adjacent surface
Power consumption (AVG. MAX.)	.30W
Dimensions (HxWxD)	1.75 x 19 x 12" (44.5 x 483 x 305mm)
Weight (approx.)	.95lbs (4.3kg)
Power supply	100 to 240VAC, 50/60Hz universal input CE and UL approved

All specifications are subject to improvement

