

World Leader • In-Rack • Audio & Video Monitoring

# WOHLER AMP1A-VTR

Compact, High Quality, 4 Channel Analog Self-Powered Speaker System



January 16, 2004

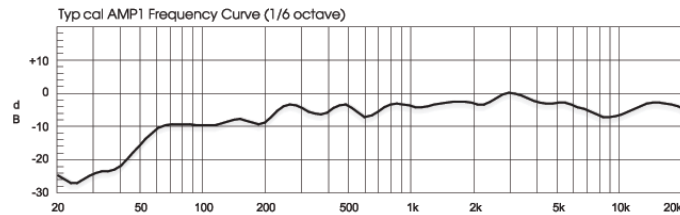

## Features:

- Full Fidelity Audio Monitoring in only 1U of rack space
- Independent Selection of 2 from 4 Mono Sources to Left and Right Outputs
- Balanced Analog Output of 2 Selected Sources
- Powerful 98dB SPL at 2 feet (0.6m)
- Four 26 Segment Tri-Color Level Meters Displaying Simultaneous VU & PPM
- Premium Quality Drivers & Power Amplifiers
- Extended Frequency Response and Low Distortion
- Focused Sound, Reduces Adjacent Bay Crosstalk
- Audible Indication of Phase/Polarity Problems
- Innovative LED Display of Phase/Polarity Relationships
- Thorough Magnetic Shielding for Placement next to Video Monitors
- Headphone Jack, Mutes Speakers
- Blowout Proof Speakers
- Quick and Simple Installation

The AMP1A-VTR provides self-powered, full-fidelity stereo audio monitoring in the smallest rack space possible. Front panel controls allow the operator to select one of four analog channels to the left and one of four to the right for aural monitoring & balanced analog output of the selected channel pair. The AMP1A-VTR features four 26 segment LED level meters showing simultaneous VU & PPM for accurate level-metering of all four input sources. This unit contains four high performance transducers driven by three power amplifiers: one amplifier/driver combination handles midrange and high frequency information in stereo, while the second handles summed low frequency information below the 500 Hz crossover point.

The unique design provides optimally focused sound for operators in an Ultra Near Field (1 to 3 ft.) working environment and offers performance comparable to that of many separate monitor pairs, yet does so without the installation hassles, awkward speaker placements and "added-on" look. This provides for a higher SPL for the operator while reducing overall ambient sound and adjacent bay crosstalk.

Extended HF response reveals potential problems with audio whine or hiss and electronic rather than acoustic cancellation of bass frequencies provides positive audible detection of out-of-phase (reversed polarity) audio feeds. A headphone jack is provided on the front panel, usage automatically mutes the speakers. The front panel features an innovative LED Display of Phase/Polarity Relationships. Output limiter circuits are incorporated to protect the speakers, and extensive magnetic shielding allows placement immediately adjacent to video monitors with no color impurities.

The AMP1A-VTR is ideally suited for use in VTR bays, mobile production vehicles, teleconferencing installations, multimedia systems, satellite link and cable TV facilities, and on-air radio studios. Built and rigorously tested in the USA, the AMP1A-VTR is backed by a strong warranty and a "Satisfaction Guaranteed" return policy.

**I-TECH COMPANY**  
www.i-techcompany.com  
Toll Free: 1-888-483-2418  
USA: 1-510-429-9288  
Fax: 1-510-372-2736

Audio Monitoring

Level Metering

Alarm Systems

Video Monitoring

**Wohler**

# WOHLER AMP1A-VTR

Compact, High Quality, 4 Channel Analog Self-Powered Speaker System

## Rear Panel:

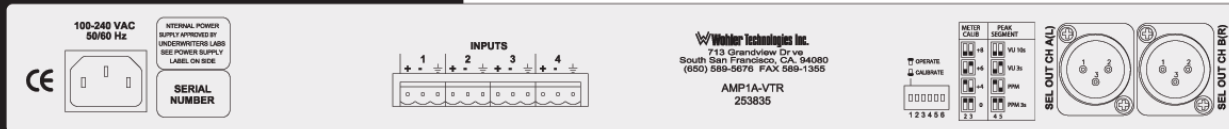

## System Diagram:

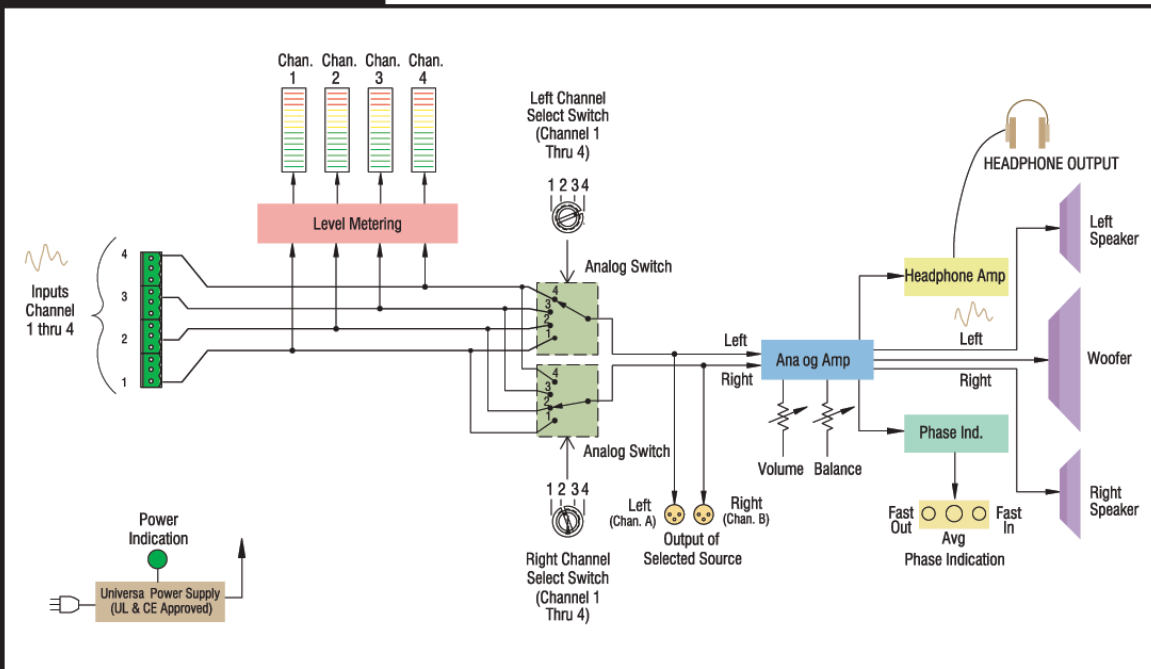

## Specifications:

Input	4 balanced analog inputs - phoenix terminals
Output	balanced analog output of 2 selected channels - XLR
Level meters	4 x 26 segment bargraphs
Level meter scale	+12 to -50 dB
Level meter threshold	.0, +4, +6, +8 dBv: DIP switch selectable
Level meter dynamics	Simultaneous VU & PPM
Midscale resolution	.2dB
Analog input impedance	>40 kOhms balanced
Peak acoustic output @ 2 feet	.98dB SPL
Frequency response (1/6 octave)	.80Hz - 20kHz ( $\pm 5$ dB) (-10dB @ 50Hz, 22kHz)
Power output	RMS each side (2 Ohms) - 5W, 7W peak RMS dual WOOFER (4 Ohms) - 11W, 16W peak
Electrical distortion	<0.15% at any level below limit threshold
Acoustic distortion	.8% or less worst case frequencies above 180Hz including cabinet resonance, typically <2%
Hum and noise	better than -68dB below full output
Magnetic shielding	<0.5 gauss any adjacent surface
Power consumption (AVG. MAX.)	.30W
Dimensions (HxWxD)	1.75 x 19 x 12" (44.5 x 483 x 305mm)
Weight (approx.)	12lbs (5.5kg)
Power supply	100 to 240VAC, 50/60Hz universal input CE and UL approved

All specifications are subject to improvement

