

World Leader • In-Rack • Audio & Video Monitoring
WOHLER AMP2-E8DA

8 Channel Analog, AES/EBU, Dolby® Digital & Dolby® E Audio Monitor



October 14, 2004

Wohler is proud to introduce the AMP2-E8DA, the world's first in-rack audio monitor capable of outputting and/or displaying "Encoded" Multi-channel audio (up to eight channels) from Dolby® E or Dolby® Digital streams.

Close cooperation with Dolby Laboratories has again ensured development of this latest Wohler product that meets the high standards for the monitoring of both Dolby® E distribution and Dolby® Digital emission coding systems.

The AMP2-E8DA features an exceptionally high quality monitoring system offering premium multi-channel audio monitoring as well as professional level metering in a compact two rackspace cabinet. This unit contains three audiophile-quality drivers and three power amplifiers; two speakers and amplifiers reproduce midrange and high frequency information in stereo, while the third amp/driver combination handles summed LF information below the 500 Hz crossover point.

Eight 53 segment high-resolution tri-color LED level meters show simultaneous VU and PPM for superior level-metering. The front panel features an innovative LCD Display of Phase/Polarity Relationships. Output limiter circuits are incorporated to protect the speakers, and extensive magnetic shielding allows placement immediately adjacent to video monitors with no color impurities.

The unique design provides optimally focused sound for operators in an Ultra Near Field (1 to 3 ft.) working environment and offers performance comparable to that of many separate monitor pairs, yet does so without the installation hassles, awkward speaker placements and "added-on" look. This provides for a higher SPL for the operator while reducing overall ambient sound and adjacent bay crosstalk.

Extended HF response reveals potential problems with audio whine or hiss and electronic rather than acoustic cancellation of bass frequencies provides positive audible detection of out-of-phase (reversed polarity) audio feeds.

Built and rigorously tested in the USA, our products are backed by a strong warranty and a "Satisfaction Guaranteed" return policy.

Features:

- Powerful 104dB SPL at 2 feet (0.6m)
- Premium Quality Drivers & Power Amplifiers
- Excellent Frequency Response and Low Distortion
- Audible Indications of Phase/Polarity Problems
- Phase-Correlation Display of Selected Channels
- Eight 53-Segment Tri-Color LED Bargraphs displaying Simultaneous VU and PPM
- Headphone Jack (mutes speakers)
- Thorough Magnetic Shielding for Placement next to Sensitive Equipment
- Front Panel Summing of any Combination of up to 8 Channels to the Left and/or Right Speakers & Selected Analog Outputs

Inputs:

- Analog Audio
- AES/EBU Audio
- Dolby® E or Dolby® Digital Audio

Outputs:

- 8 Analog Outputs from Analog Inputs or Converted from AES/EBU Digital Inputs
- 4 AES/EBU Digital Outputs
- Simultaneous AES/EBU output of decoded Dolby® E/Dolby® Digital
- 8 Channel Analog Output is NOT Available from Dolby® encoded sources

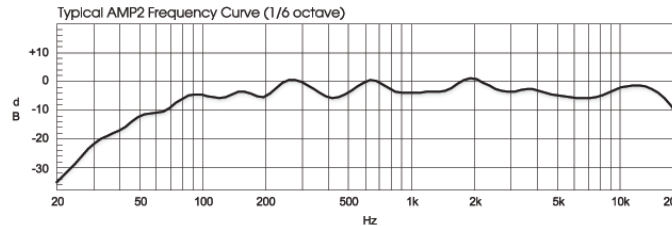

i-TECH COMPANY
 www.i-techcompany.com
 Toll Free: 1-888-483-2418
 USA: 1-510-429-9288
 Fax: 1-510-372-2736



Audio Monitoring | Level Metering | Alarm Systems | Video Monitoring

WOHLER AMP2-E8DA

8 Channel Analog, AES/EBU, Dolby® Digital & Dolby® E Audio Monitor

Rear Panel:

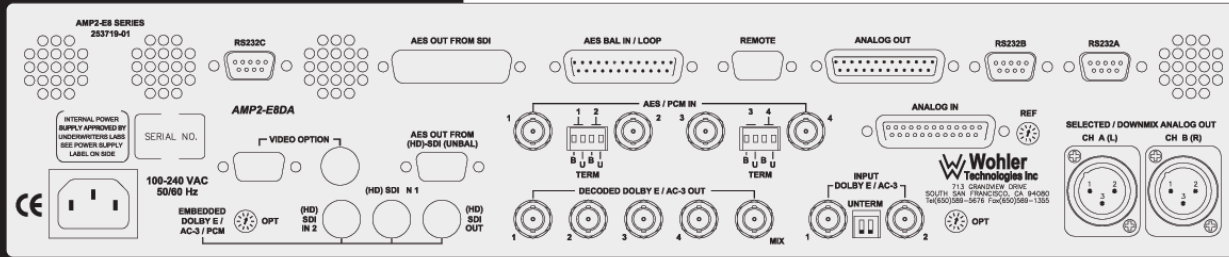

System Diagram:

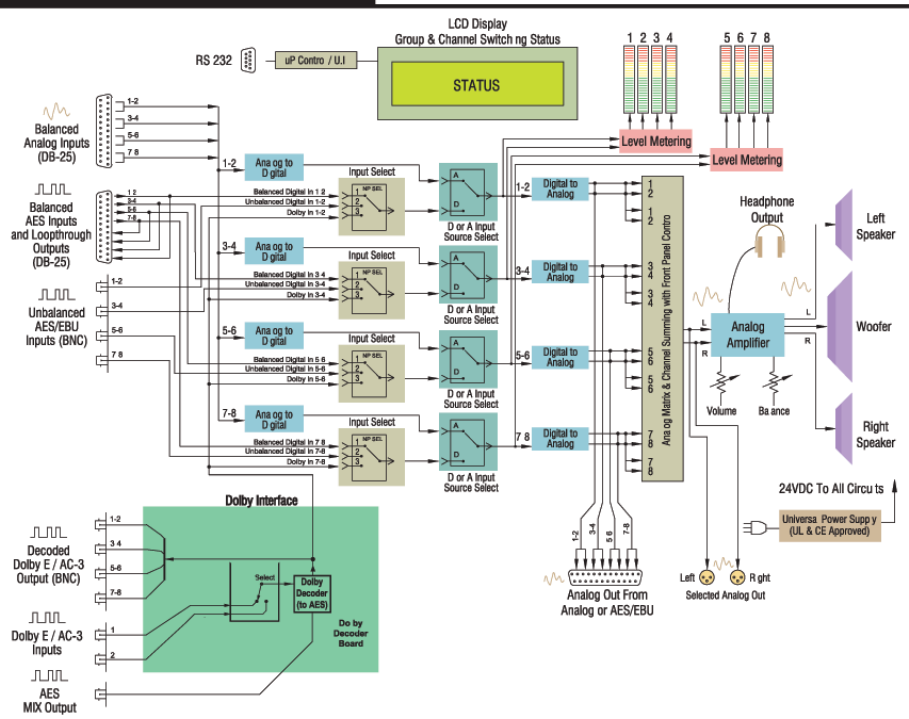

Specifications:

AES/EBU inputs	4 unbalanced AES/EBU inputs (BNC) and 4 balanced AES/EBU inputs (DB-25)
Analog input	8 balanced analog inputs (DB-25)
Analog output	8 balanced analog outputs from AES/EBU or analog (DB-25) and 2 balanced analog outputs from selected channels (XLR)
AES/EBU outputs	4 balanced AES/EBU outputs looped from the 4 balanced AES/EBU inputs (DB-25)
Dolby E/Dolby Digital® or PCM inputs	2 unbalanced inputs (BNC)
Level meters	8 x 53 segment
Level meter scale	0 to -66 dB
Level meter threshold	0, +4, +6 or +8dBv: switch selectable
Level meter dynamics	Simultaneous VU & PPM
Midscale resolution	1dB
Peak acoustic output @ 2 feet	104dB SPL
Power output	RMS each side (4 Ω) - 10W, 14W peak RMS center WOOFER (4 Ω) - 25W, 35W peak
Frequency response (1/6 octave)	20Hz - 16kHz (±5dB) (-10dB @ 40Hz, 20kHz)
Analog input impedance	>40 kΩ balanced
AES/EBU input termination	110 Ω balanced 75 Ω unbalanced
AES/EBU input sampling rate	32-48kHz, auto-detecting
Hum and noise	better than -68dB below full output
Electrical distortion	<0.15% at any level below limit threshold
Acoustic distortion	0.6% or less worst case frequencies above 140Hz including cabinet resonance, typically < 1.5%
Magnetic shielding	<0.8 gauss any adjacent surface
Power consumption (AVG. MAX.)	60W
Dimensions (HxWxD)	3.5 x 19 x 12" (89 x 483 x 305mm)
Weight (approx.)	18lbs (8.2kg)
Power supply	100 to 240VAC, 50/60Hz universal input CE and UL approved

All specifications are subject to improvement
"Dolby" and the double-D symbol are trademarks of Dolby Laboratories.