

World Leader • In-Rack • Audio & Video Monitoring

WOHLER E MON-1/SDI

8 Channel Dolby E, Dolby Digital & PCM Audio Monitor

DOLBY
DIGITAL

Dolby E
PARTNER

January 28, 2004



Features:

- Decodes Dolby E, Dolby Digital and PCM Inputs
- Deembeds Dolby E, Dolby Digital and PCM from an SDI input
- Monitor up to 8 Channels of Audio
- Select from 2 Dolby E, Dolby Digital or PCM Inputs
- Source 1: SDI Input with Reclocked Output
- Front Panel SDI Group & Subgroup Selection
- Source 2: Either Balanced or Unbalanced Dolby E, Dolby Digital or PCM
- Analog Output of Selected Pair or Multichannel Downmix
- Eight High Resolution 53 Segment Level Meters Showing Simultaneous VU & PPM
- Includes an Internal Dolby E & Dolby Digital Decoder
- LCD Displays System Status Information
- Displays Dolby E & Dolby Digital Bit Stream Metadata Information
- Powerful 104dB SPL at 2 feet (0.6m)
- Premium Quality Drivers & Power Amplifiers
- Excellent Frequency Response and Low Distortion
- Focused Sound, Reduces Adjacent Bay Crosstalk
- Audible Indication of Phase/Polarity Problems
- Output Limiter Protected Speakers
- Thorough Magnetic Shielding for Placement next to Video Monitors

Wohler is proud to introduce the E MON-1/SDI, the world's first in-rack audio monitor capable of outputting and/or displaying audio from Dolby E®, Dolby Digital® & PCM streams deembedded from SDI. We worked closely with Dolby Laboratories to ensure development of a product that would meet high standards for the monitoring of both Dolby E® distribution and Dolby Digital® emission coding systems.

The E MON-1/SDI features an exceptionally high quality audio monitoring system offering premium quality multi-channel audio monitoring as well as professional level metering in a compact two rackspace cabinet. This unit contains three audiophile-quality drivers and three power amplifiers; two speakers and amplifiers reproduce midrange and high frequency information in stereo, while the third amp/driver combination handles summed LF information below the 500 Hz crossover point.

Eight 53 segment high-resolution tri-color LED level meters show simultaneous VU and PPM for superior level-metering. Output limiter circuits are incorporated to protect the speakers, and extensive magnetic shielding allows placement immediately adjacent to video monitors with no color impurities.

The unique design provides optimally focused sound for operators in an Ultra Near Field (1 to 3 ft.) working environment and offers performance comparable to that of many separate monitor pairs, yet does so without the installation hassles, awkward speaker placements and "added-on" look. This provides for a higher SPL for the operator while reducing overall ambient sound and adjacent bay crosstalk. Extended HF response reveals potential problems with audio whine or hiss and electronic rather than acoustic cancellation of bass frequencies provides positive audible detection of out-of-phase (reversed polarity) audio feeds.

Built and rigorously tested in the USA, our products are backed by a strong warranty and a "Satisfaction Guaranteed" return policy.

Wohler

**i-TECH
COMPANY**
www.i-techcompany.com
Toll Free: 1-888-483-2418
USA: 1-510-429-9288
Fax: 1-510-372-2736

Audio Monitoring

Level Metering

Alarm Systems

Video Monitoring

WOHLER E MON-1/SDI

8 Channel Dolby E, Dolby Digital & PCM Audio Monitor

Rear Panel:

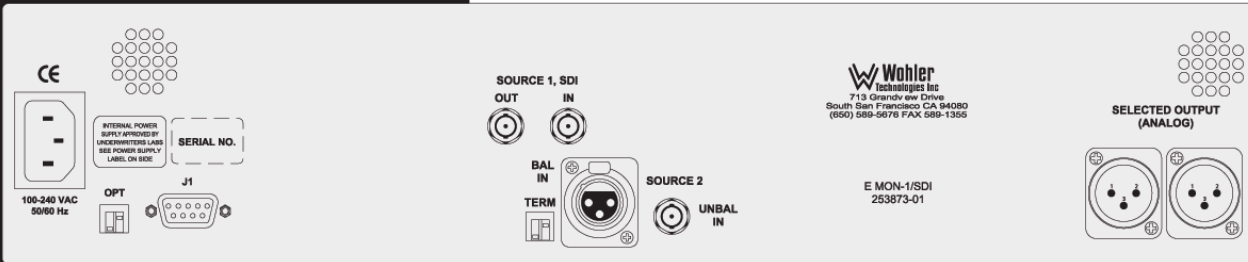

System Diagram:

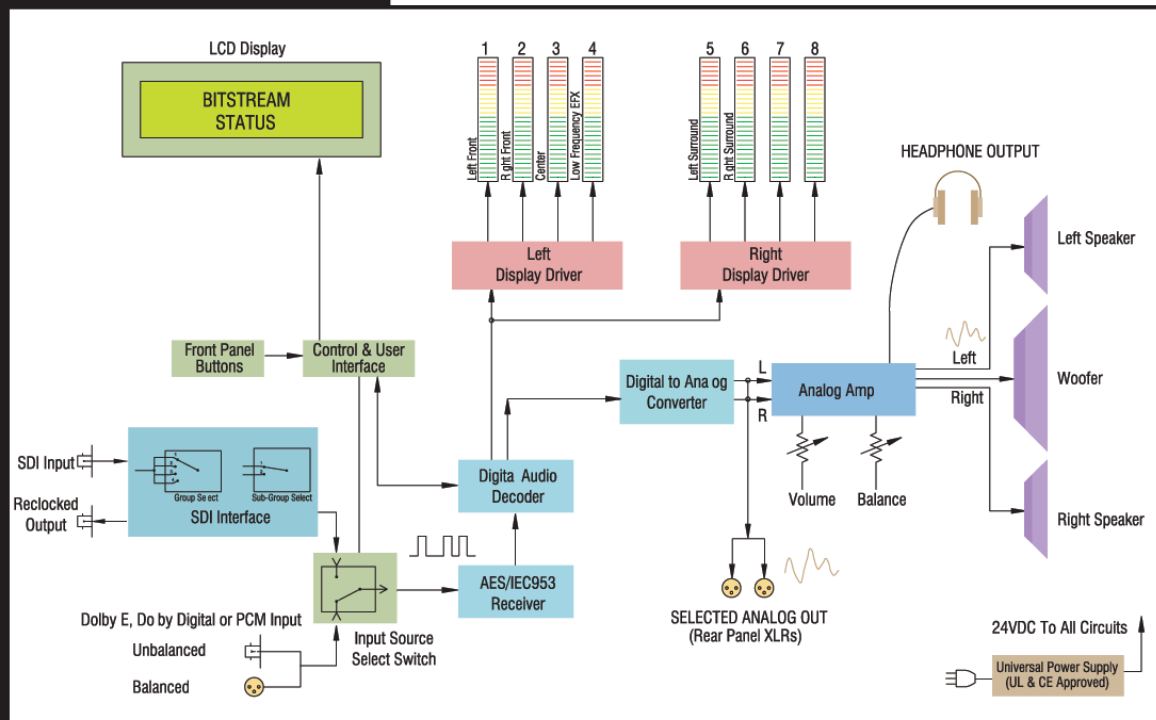

Specifications:

Input Source 1	SDI Input with relocked output, BNC
Input Source 2	Dolby E, Dolby Digital or PCM Inputs, 1 balanced (XLR) or unbalanced (BNC) input
Analog output	balanced analog output of 2 selected channels or multi-channel downmix, XLR
Level meters	.8
Level meter no. of segments	.53
Level meter scale	.0 to -66
Level meter dynamics	simultaneous VU & PPM
Midscale resolution	1 dB
Peak acoustic output @ 2 feet	104dB SPL
Power output	RMS each side (4 Ohms) - 10W, 14W peak RMS center WOOFER (4 Ohms) - 25W, 35W peak
Frequency response (1/6 octave)	.80Hz - 16kHz (±5dB) (-10dB @ 40Hz, 20kHz)
Input termination	110 Ohms balanced, 75 Ohms unbalanced
Hum and noise	better than -68dB below full output
Electrical distortion	<0.1% at any level below limit threshold
Acoustic distortion	.6% or less worst case frequencies above 140Hz including cabinet resonance, typically < 1.5%
Magnetic shielding	<0.8 gauss any adjacent surface
Power consumption (AVG. MAX.)	.45W
Dimensions (HxWxD)	.35 x 19 x 12" (44.5 x 483 x 305mm)
Weight (approx.)	.18lbs (8.2kg)
Power supply	100 to 240VAC, 50/60Hz universal input CE and UL approved

All specifications are subject to improvement

"Dolby" and the double-D symbol are trademarks of Dolby Laboratories.

