

# COMPACT DESIGN PANEL PC

9.0" 1024 x 600 300nits Panel PC DMP Vortex86EX 933MHz, 2GB DDR3 Memory on board, +5VDC, IP65 standard front panel, waterproof and dustproof, and wide operating temperature range from -20C to 60C (-4F to 140F) 110/220V external power adapter. CF Card Support, support Linux, Win CE, Win XP, Win 7, Windows Embedded Standard

Model: XPC0900X2-2G



## FEATURES

- 9" TFT LCD with resistive touchscreen
- DM&P Vortex86DX2-933MHz Onboard
- 1GB/ 2GB DDR2 System Memory Onboard
- Fanless and Low Power Consumption
- Metal Chassis with Compact Design
- CF Card, Micro SD slot (Optional)
- 1G / 2G Flash Memory onboard (Optional)



## SPECIFICATIONS

LCD Display	
Type	VGA TFT LCD
Size	9"
Resolution (Pixel)	1024x600
Colors	262,144
View Angle	Vertical 120° / Horizontal 140°
Brightness	300 cd/m2
Backlight Life	18,000 hrs
Contrast Ratio	500 : 1
System Specs	
CPU	DM&P Vortex86DX2-933MHz
Cache	L1: 16KB I-Cache, 16KB D- Cache / L 2: 256KB Cache
Memory	1GB / 2 GB DDR2 Memory Onboard
Watchdog Timer	Software Programmable from 30.5u to 512 Seconds x 2 Sets
Serial Port	RS-232 / 422 / 485 x 1
USB Ports	USB Ports (Version 2.0) x 2
Ethernet	Integrated 10/100M Ethernet
Audio	HD Audio-Realtek ALC262 CODEC
Internal Drives	CF Card; Micro SD slot, 1G / 2G Flash Memory onboard (Optional)
Touch Screen Type	Analog Resistive
Expansion Slot	None
Power Requirement	Single Voltage +5VDC ( 5A )/ Multi Voltage +8~+35VDC ( 8A )
Power Consumption	20W (Max.)
Operating Temperature	0~+50°C (32~+122°F) / -20~+60°C (-4~+140°F) Optional & CPU down to 800MHz (-I)
Storage Temperature	-30~ +70°C (14 ~+158°F)
Operating Humidity	0% ~ 90% Relative Humidity, Non-Condensing
Operating System	Linux, Win CE, Win XP, Win 7, Windows Embedded Standard
Dimensions	236.6x146x35mm (9.31x5.75x1.38 inches)
Weight	790g
Certificate	CE / FCC / VCCI / Vibration / Shock / IP65 (Front Panel)

# MECHANICAL DRAWINGS

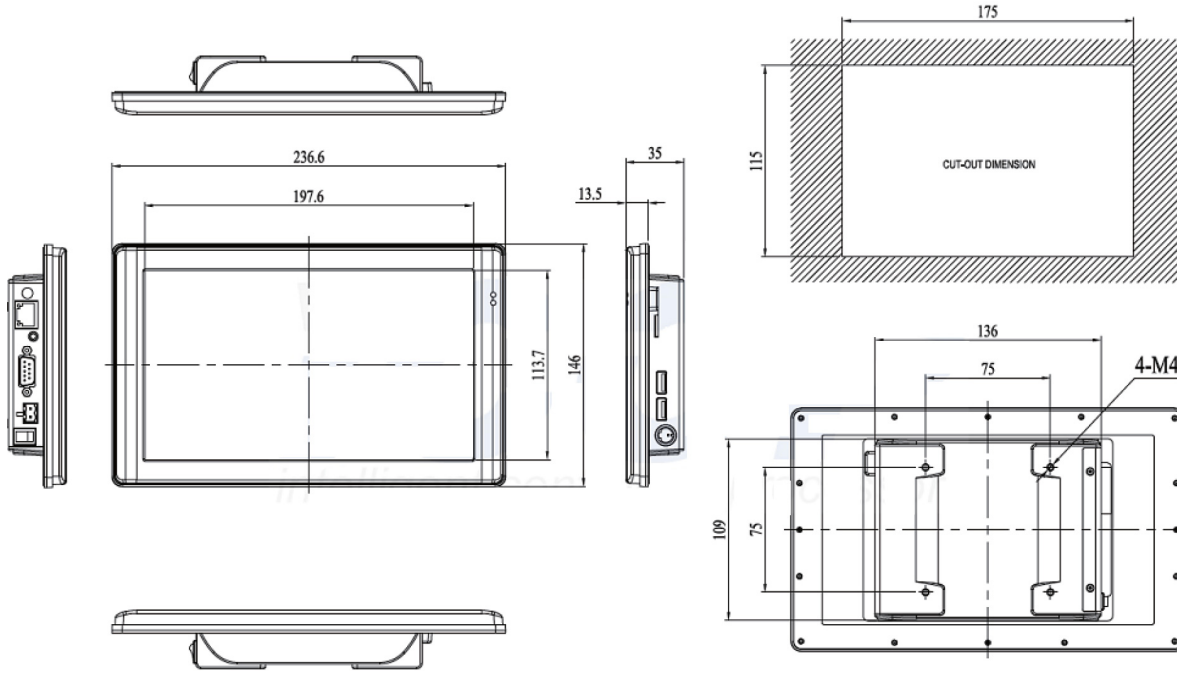

Unit: mm

## I/O OVERVIEW

### RIGHT SIDE

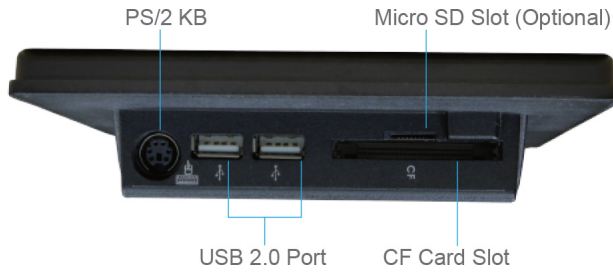

### LEFT SIDE

