

COMPACT DESIGN PANEL PC

9.0" 1024 x 600 300nits Panel PC DM&P Vortex86DX2 Onboard, 1GB DDR3 Memory on board, +24VDC, IP65 standard front panel, waterproof and dustproof, and wide operating temperature range from -20C to 60C (-4F to 140F) RS232/422/485 x 2, USB 2.0 x 3, CF Card Support, 2 Serials Ports available, support Linux, Win CE, Win XP, Win 7, Windows Embedded Standard



Model: XPC0900X4-1G

FEATURES

- 9" TFT LCD with resistive touchscreen
- DM&P Vortex86DX2 Onboard
- 512 /1GB/2 GB System Memory Onboard
- Compact Flash Type I/II SD Slots /SATA Slim
- Fanless and Low Power Consumption
- Metal Chassis with Compact Design



SPECIFICATIONS

LCD Display	
Type	WSVGA TFT LCD
Size	9"
Resolution (Pixel)	1024x600
Colors	262,144
View Angle	Vertical 120° / Horizontal 140°
Brightness	300 cd/m2
Backlight Life	18,000 hrs
Contrast Ratio	500 : 1
System Specs	
CPU	DM&P Vortex86DX2
Cache	L1: 16KB I-Cache, 16KB D- Cache / L 2: 256KB Cache L1: 32KB I-Cache, 32KB D- Cache / L 2: 152KB Cache
Memory	512MB /1GB / 2GB DDR2 (DDR3) Memory Onboard
Watchdog Timer	Software Programmable from 30.5u to 512 Seconds x 2 Sets
Serial Port	RS-232 / 422 / 485 x 1
USB Ports	USB Ports (Version 2.0) x 3
Ethernet	Integrated 10/100M Ethernet (PoE Optional) / Giga Ethernet (Optional)
Audio	HD Audio-Realtek ALC262 CODEC
Internal Drives	Compact Flash Type I/II Slot, SD Slot (optional), SATA Slim
Touch Screen Type	Analog Resistive
Expansion Slot	WLAN Optional
Power Requirement	+ 12-+24VDC
Power Consumption	+24VDC@1A
Operating Temperature	0-+50 C (+32- +122°F)/-20 C ~+60°C (-4~+140 F)
Storage Temperature	-30-+70 C (-22~+158°F)
Operating Humidity	0% ~ 90% Relative Humidity, Non-Condensing
Operating System	Linux, Win CE, Win XP, Win 7, Windows Embedded Standard
Dimensions	242x156.5x44mm (9.68"x6.26"x1.76")
Weight	1.36 kg
Certificate	CE, FCC, VCCI, Vibration, IP65 (Front Panel)

**Specifications subject to change without notice, not responsible for typographical errors.*

MECHANICAL DRAWINGS

This is subject to change without Notice. Final Drawings Will be Provided for Approval after Order.

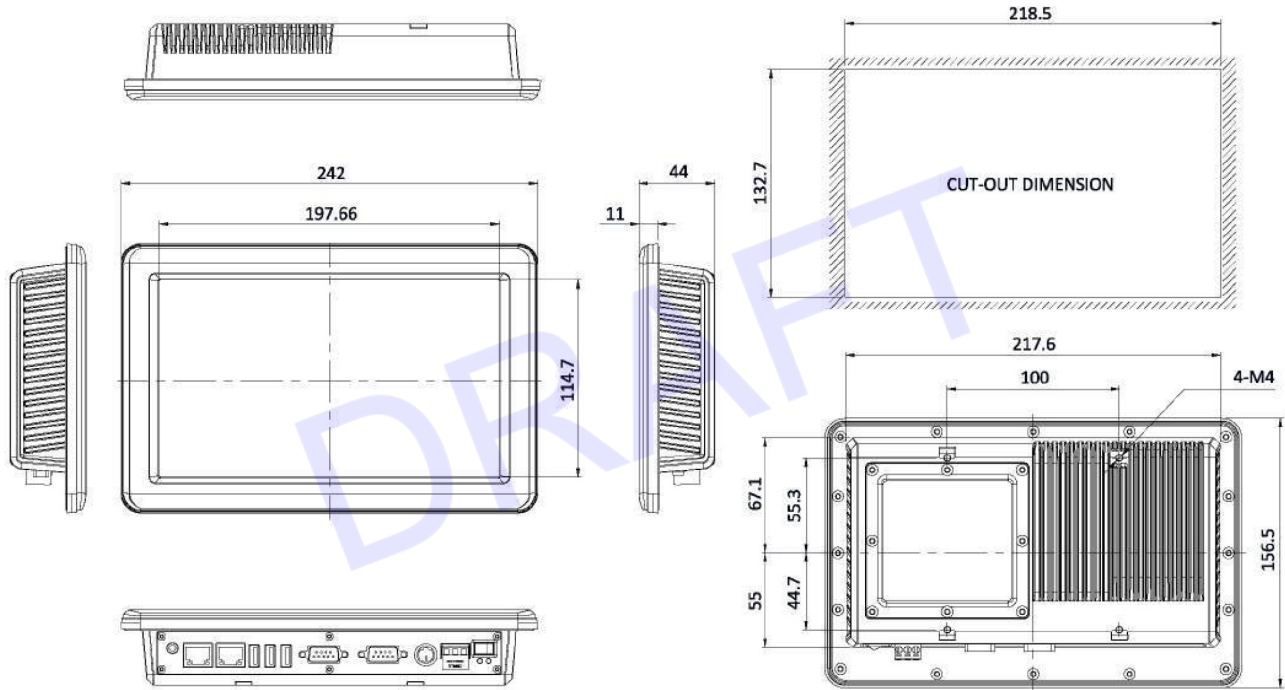

Unit: mm

I/O OVERVIEW

Available for max. total 7 RS232 ports or 16-bit GPIO and 5 RS232 ports solution

