

# COMPACT DESIGN PANEL PC

5.7" TFT LCD DM&P Vortex86DX3-1GHz Onboard  
Fanless and Low Power Consumption Metal Chassis  
with Compact Design with Resistive Touchscreen

(Model: XPC570X3)



## FEATURES

- 5.7" TFT LCD with resistive touchscreen
- DM&P Vortex86DX3-1GHz Onboard
- 1G / 2G DDR3 System Memory Onboard
- Fanless and Low Power Consumption
- Metal Chassis with Compact Design
- CF Card, Micro SD slot (Optional) 1G / 2G Flash Memory onboard (Optional)



CE



FCC



VCCI



VIBRATION



TOUCH



Wi-Fi



FANLESS

## SPECIFICATIONS

LCD Display	
Type	VGA TFT LCD
Size	5.7"
Resolution (Pixel)	640(W) x 480 (H)
Colors	262,144
View Angle	Vertical 100° / Horizontal 140°
Brightness	500 cd/m2
Backlight Life	50,000 hrs
Contrast Ratio	300 : 1
System Specs	
CPU	DM&P Vortex86DX3-1GHz
Cache	L1: 16KB I-Cache, 16KB D- Cache / L 2: 256KB Cache
Memory	1GB / 2 GB DDR3 Memory Onboard
Watchdog Timer	Software Programmable from 30.5u to 512 Seconds x 2 Sets
Serial Port	RS-232 / 422 / 485 x 1
USB Ports	USB Ports (Version 2.0) x 2
Ethernet	Integrated 10/100M Ethernet
Audio	HD Audio-Realtek ALC262 CODEC
Internal Drives	CF Card ; Micro SD slot, 1G / 2G Flash Memory onboard (Optional)
Touch Screen Type	Analog Resistive
Expansion Slot	None
Power Requirement	Single Voltage +5VDC ( 5A ) / Multi Voltage +8~+35VDC ( 8A )
Power Consumption	20W (Max .)
Operating Temperature	0~+50°C (32~+122°F) / -20~+60°C (-4~+140°F) Optional & CPU down to 800MHz (-I)
Storage Temperature	-30~ +70°C (14 ~+158°F)
Operating Humidity	0% ~ 90% Relative Humidity, Non-Condensing
Operating System	Linux, Win CE, Win XP, Win 7, Windows Embedded Standard
Dimensions	152x112x33mm (5.98x4.41x1.3 inches)
Weight	500g
Certificate	CE / FCC / VCCI / Vibration / Shock

# MECHANICAL DRAWINGS

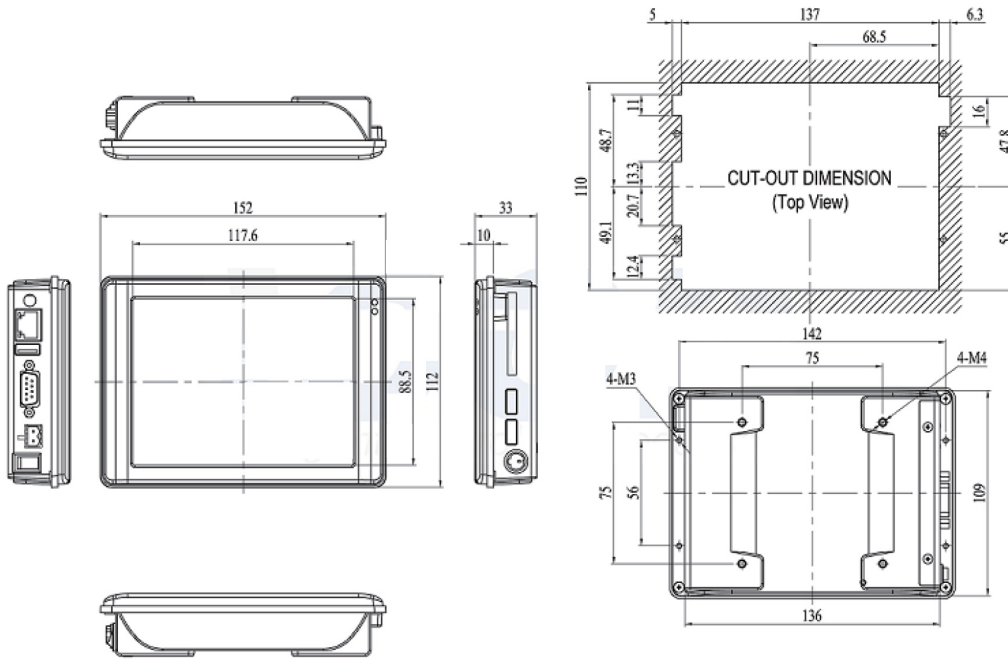

Unit: mm

## I/O OVERVIEW

### RIGHT SIDE

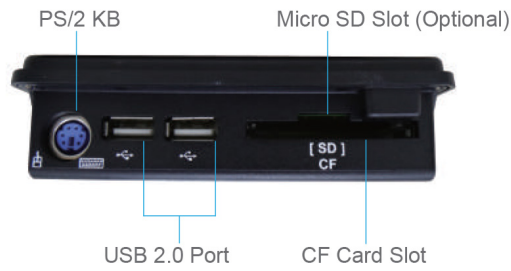

### LEFT SIDE

#### Standard



#### DC Input

