

# Industrial Chassis/Surface Mount Metal Housing

Industrial Chassis/Surface Mount Metal Housing High Brightness 32"  
LCD 1920\*1080 1000nits 3000:1 with VGA input



## Model: YCHR3200HB

### FEATURES:

- High contrast color TFT-LCD Monitor support resolution up to 1920 x 1080.
- Power management system conforms to VESA DPMS and EPA Energy Star standards.
- Universal Power adapter.
- Support DDC1 & DDC2B for Plug & Play compatibility.
- Advanced OSD control for picture quality adjustment.
- Detachable stand for wall-mounting adjustment.
- Heavy duty monitor with steel frame.
- Custom design by request.

### System Specifications

Item	Specification
Panel Type	32-inch TFT LCD
Screen Diagonal	32-inch
Active Display Area (mm)	698.4 (H) x 392.85(V)
Pixel Pitch (mm)	0.3637 (H) x 0.3637 (W)
Number of Pixels	1,920x1,080
Contrast Ratio	3000:1
Display Color	16.7M colors (8 bit)
Brightness (cd/m)	1000 cd/m
Viewing Angle(Typ.)	89 / 89 / 89 / 89 ( R/L/U/D)
Signal Connector	15 PIN D-Sub,DVI-D
Power Source	AC100 ~ 240V, Universal +/- 10%
Power Management	VESA DPMS Compliant
Operating Temperature	0 ~ +50 °C
Storage Temperature	-20 ~ +60°C
Plug & Play	VESA DDC 1/2B

\* Specifications are subject to change without notice

Touch Screen (Optional)	Signal Input	Color	Other
N: No touch screen or glass	C: VGA Only	B: Black	N: N/A
G: Glass	D: VGA + DVI-D		R: Bracket (rear mount)
R: Resistive, RS232	E: VGA + DVI-D+Audio		S: Stand
U: Resistive, USB	J: VGA + DVI-I+Audio + HDMI		

**DIMENSIONS:**

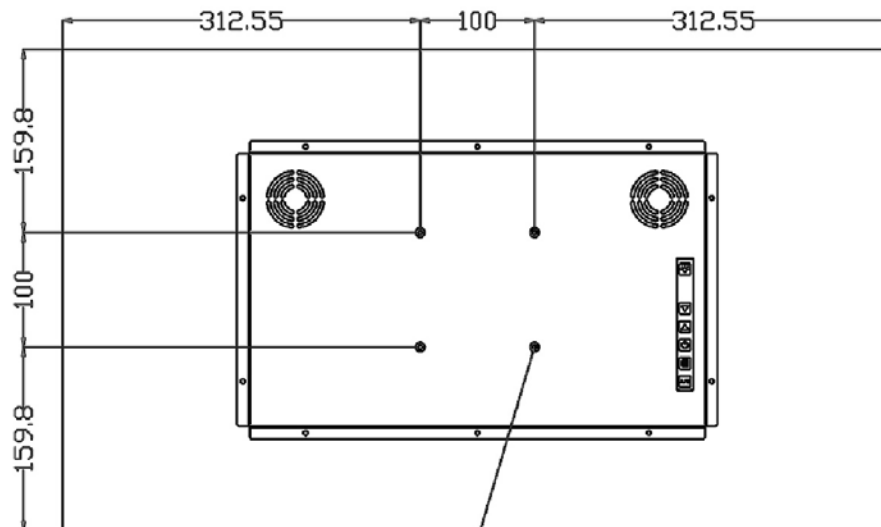
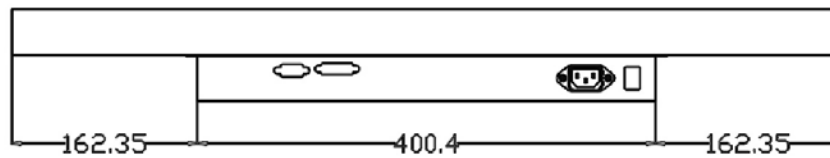
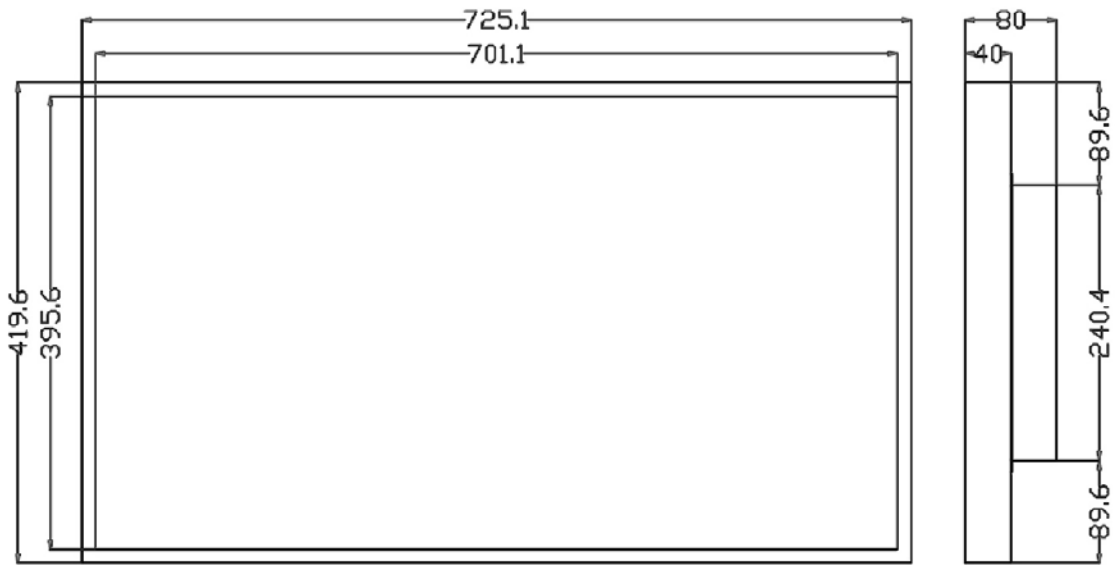

M4 SCREW USER HOLE  
DP=8.0 MAX SCREW PENATRATION

*Note: this is a simplified drawing and some components are not made in detail.  
Please contact our sales representative if you need further product's information.*