

Sunlight Readable Panel Mount High Brightness LCD

Panel Mount Metal Housing Integrated IP65 Front Panel
 AI-5mm with AR coating glass, 32" LCD 1920*1080 1000nits 1000:1 with
 VGA + DVI input Operating Temp 5F to 140F (-15C to 60C) with Dimming
 controller + PCAP Touch with USB Controller Dual touch for Window 7

Model: YPMW3200PHB-PCAP



1000nits

FEATURES:

- High contrast Color TFT-LCD Monitor support resolution up to 1920 x 1080.
- Light Sensor at front bezel top middle
- VGA + DVI input
- Auto power and signal on/off
- Life time 60K hours, operating Time 24 hours/Per day (Moving Pictures)
- Panel Enhancement to prevent isotropic blackout under Direct Sun up to 85°C
- One(1) Year Return to Depot Warranty

SPECIFICATIONS:

Item	Specification
Panel Type	32.0-inch TFT LCD
Screen Diagonal	32.0-inch
Active Display Area (mm)	698.4 (H) x 392.85(V)
Pixel Pitch (um)	0.3637 (H) x 0.3637 (W)
Number of Pixels	1,920x1,080
Contrast Ratio	1000:1
Color Arrangement	R.G.B. Vertical Stripe
Brightness (cd/m ²)	1000 cd/m ²
Viewing Angle(Typ.)	89/89/89/89 (R/L/U/D)
Signal Connector	15 PIN D-Sub, DVI-D
Power Source	110/220V AC, Universal +/- 10%
Power Management	VESA DPMS Compliant
Operating Temperature	-15°C to 60°C
Plug & Play	VESA DDC 1/2B
Touch	PCAP Touch with USB Controller Dual touch for Window 7
Anti Shock	30G
Anti Vibration	1G (2-200Hz)

MECHANICAL DRAWINGS:

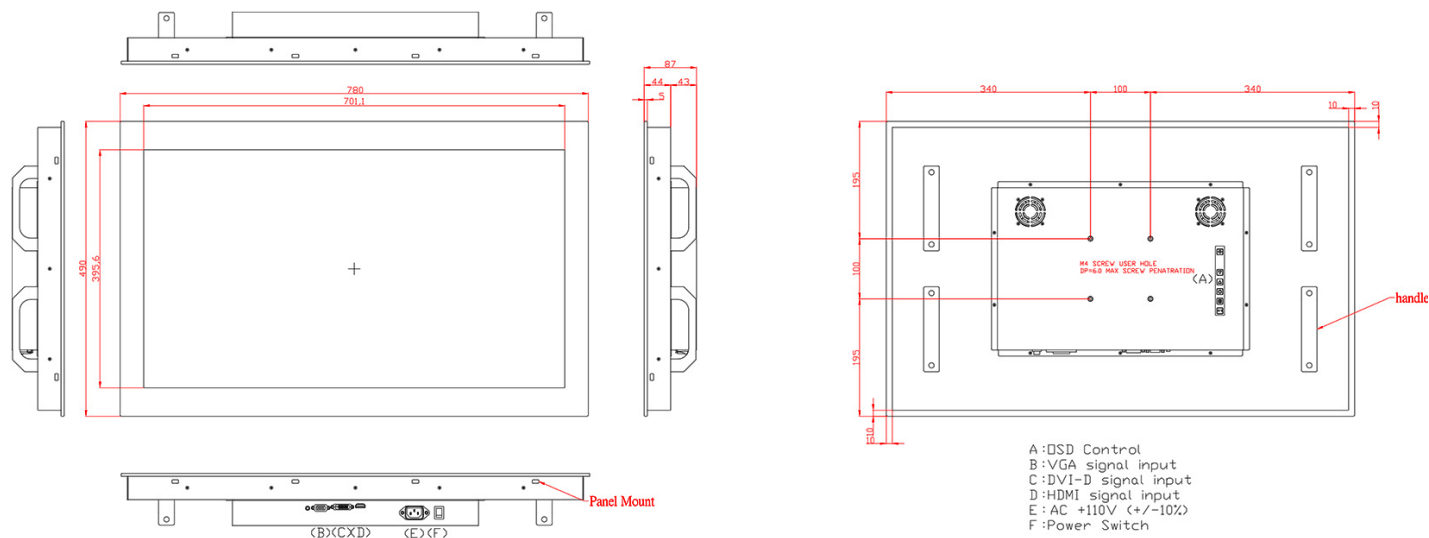

Note
 1.Unspecified tolerances are ±0.5mm
 2.This drawing is only data and can be changed without previous notice
 3.Recommend to fasten all user holes for better mechanical strength