

# MILITARY KEYBOARD

Full-sized versatility rugged, compact, mobile keyboard with numeric keypad and robust polycarbonate.



## Model: Ymil-K200

The Ymil-K200 keyboard provides full-sized versatility in a rugged, compact design. Engineered for NEMA 4X protection from dust, water and corrosive liquids, the Ymil-K200 is ideal for use in environments ranging from manufacturing to material handling. The large numeric pad on the Ymil-K200 allows for easy data entry, while its robust polycarbonate case stands up to the roughest of conditions. VESA MOUNTING PATTERN: 8-32 Threaded Inserts in 2.5" x 2.5" and 1.19" x 1.5" Patterns.

### FEATURES:

- 12 Function Keys
- Built-In Mounting Holes (VESA)
- Large, 10-Key Numeric Pad
- MS Windows™ Function Keys
- Slim, Compact Design
- USB and PS/2 configurations available

### SPECIFICATIONS:

<b>CERTIFICATIONS</b>	NEMA 4X UL60950, FCC Part 15 Class B
<b>SHOCK</b>	3x11 ms pulses of 50g on each of 3 axes
<b>CABLE</b>	LENGTH: 10' straight (3 m)
<b>KEY SWITCH</b>	MATERIAL: Industrial silicone rubber LIFE: 10 million cycles TRAVEL: 0.055 in. (1.4mm) ACTUATION FORCE: 7.05 oz +/- 1.06 oz (200g +/- 20g) FEEDBACK: Tactile with mechanical snap
<b>VIBRATION</b>	POWER SPECTRAL DENSITY: 0.04g/Hz FREQUENCY RANGE: 20Hz - 2 kHz DURATION OF TEST PER AXIS: 3 hours
<b>POWER</b>	PS/2: 50mA@5V (from Keyboard port) USB: 50mA@5V (from CPU port)
<b>COMPATIBILITY</b>	PS/2: All Windows Operating Systems USB: All Windows and Macintosh OS
<b>TEMPERATURE RANGE</b>	STORAGE: -40C to +90C (-40F to +194F) OPERATING: -40C to +70C (-40F to +158F)
<b>WEIGHT</b>	2 lbs +/- 0.10 lbs (0.91 kg +/- 0.05 kg)
<b>WARRANTY</b>	1 year limited warranty
<b>HUMIDITY</b>	100%
<b>MOUNTING</b>	VESA MOUNTING PATTERN: 8-32 Threaded Inserts in 2.5" x 2.5" and 1.19" x 1.5" Patterns
<b>DIMENSIONS</b>	14.50" x 5.50" x 1.56" (w-h-d) 368.3mm x 139.7mm x 39.6mm

*\*Specifications subject to change without notice, not responsible for typographical errors.*

## MECHANICAL DRAWING

This is subject to change without Notice. Final Drawings Will be Provided for Approval after Order.



### KEY SWITCH

MATERIAL: Industrial Silicone Rubber  
LIFE: Greater Than 10 Million Cycles  
TRAVEL: 0.055 in.  
ACTUATION FORCE: 7.05 oz. +/- 1.06oz (200g +/- 30g)  
FEEDBACK: Tactile with Mechanical Snap

### TEMPERATURE RANGE

STORAGE: -40°F to +194°F (-40°C to +90°C)  
OPERATING: -40°F to +158°F (-40°C to +70°C)

### VIBRATION

POWER SPECTRAL DENSITY: .04g/HZ  
FREQUENCY RANGE: 20Hz-2Khz  
DURATION OF TEST PER AXIS: 3 hours

### POWER

PS2: 50mA@5V (from Keyboard port)  
USB: 50mA@5V (from CPU port)

### HUMIDITY

100% Humidity Resistant

### SHOCK

3 X 11 ms pulses of 50g on each of 3 axis

### WEIGHT

2.00 lbs +/- 0.10 lbs (0.91 kg +/- 0.05 kg)

## BACK / MOUNTING

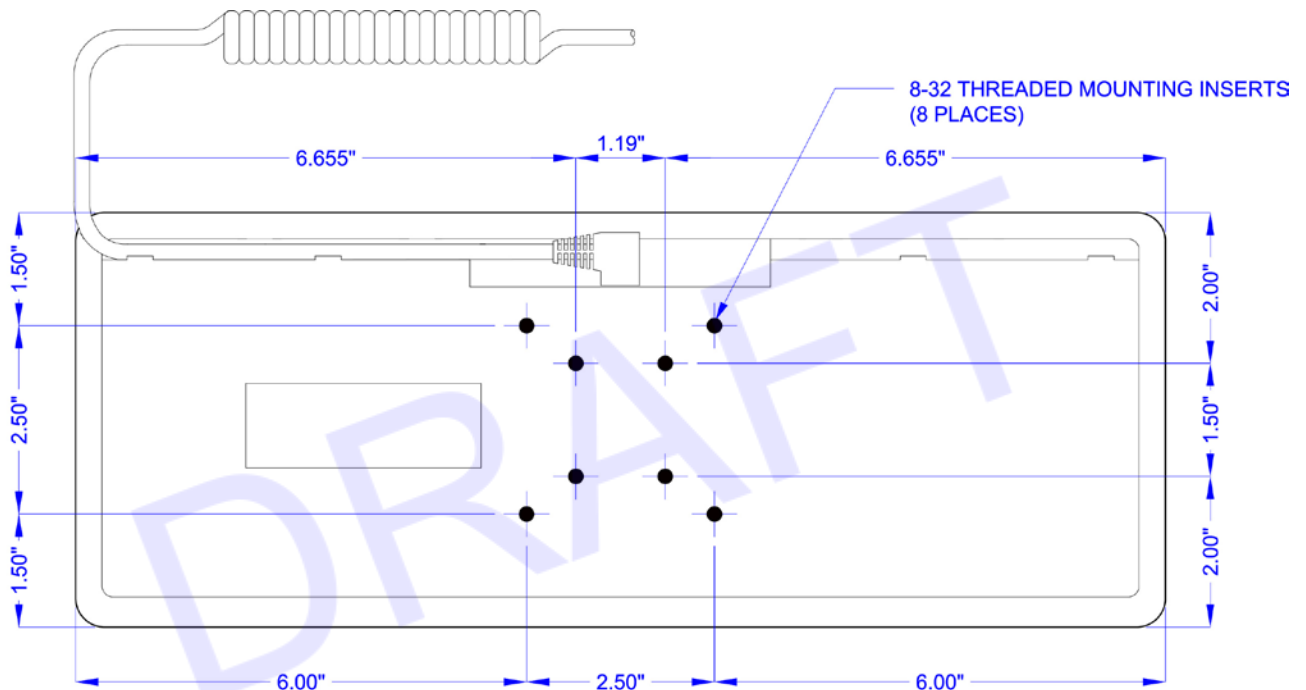

ENCLOSURE CASE: ABS/Polycarbonate