

Fanless PANEL PC



Fanless Panel PC 12.1" Core2Duo 2.0GHz GM45 2GB (Max8GB) 2.5" 320GB 2 GigaLAN 4 COM3 @ 422/485 120W Adapter XP Pro 350 cd/m² Slim DVD-RW PCI x1

Model: BBC1210DVD

Features:

- Fanless Design, with System Fan for option
- Front Panel OSD Keypad
- Front Panel Waterproof USB
- Support RAID 0, 1
- 9~32V DC Wide Range Power Input

Specifications

Processor System	Intel Socket P Core 2 Duo Processor FSB 667/800/1066 MHz, up to Intel T9400 2.53GHz
Memory	2 x 204 Pin DDR3 SO-DIMM, up to 8 GB SDRAM
System Chipset	Intel GM45 + ICH9M-E
External I/O Port	2 x GbE LAN connectors 1 x VGA 2 x RS-232 (COM1/2) 1 x terminal block for additional power switch 2 x LED light for power and HDD indication 1 x Audio line out/ MIC in 1 x DB-9 RS-422/485, default RS-485 (COM3) for option 1 x 8 Pin terminal block connector for VCC/Ground/6XGPIO 1 x USB 2.0 connector with cap at front panel 1 x 3 Pin DC Power input terminal block
Storage	2 x 2.5" SATA HDD (one HDD as standard, two HDDs as option for RAID) 1 x External CF Slot for option
CD/DVD-R Device	1 x Slim CD/DVD RW Device for option (Not available if 2 HDD and CF have been used)
Wireless LAN	mini-PCIe interface for option
Expansion Slots	1 x PCI for option
Other optional Function	Web CAM USB Device Auto Dimming 2 x 2W Speaker
Power Input	9~32V DC
Touch Screen	Resistive Touch Screen (option)
Light Transmission	80%
OS Support	Windows XP Professional, XP Embedded, Windows Embedded Standard 7, Windows 7 Pro for Embedded



LCD

Display Type	12.1" TFT-LCD
Max. Resolution	800x600
Max. Color	262K
Luminance (cd/m ²)	350
Backlight Lifetime	50,000 hrs

Mechanical

Construction	Aluminum front bezel and steel chassis
IP Rating	Front Panel IP 65 Compliance
Mounting	Panel / VESA 75 Mount
Dimension	390x264x91.5
Weight	7.6kgs

Environmental

Operating	-10-50 °C
Storage Temperature	-20-60 °C
Storage Humidity	10-90% @40 °C non-condensing
Certificate	CE/FCC Class A Compliance

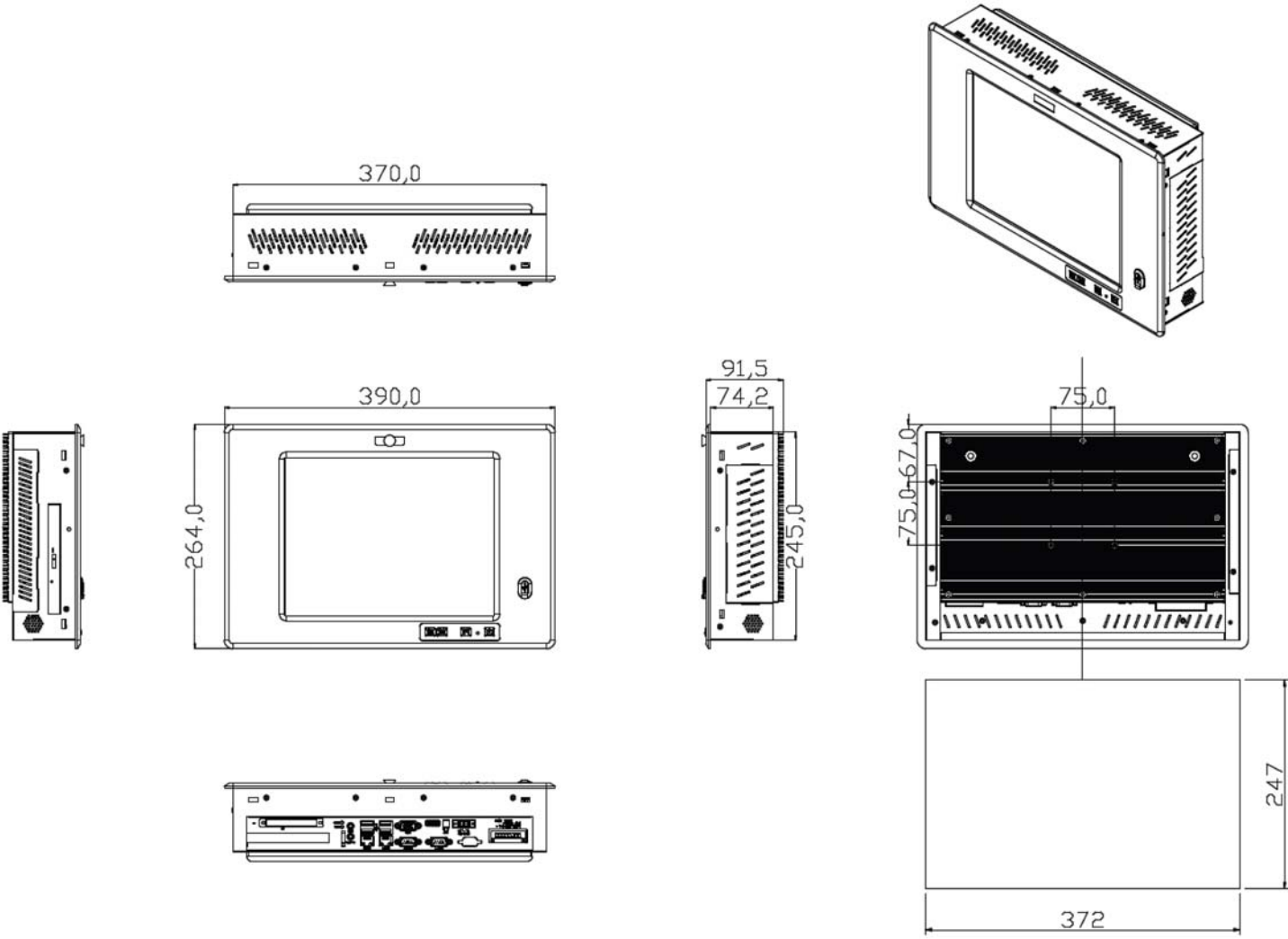

Mounting Hole Size