

## iMC1700/1900 All-in-One Medical Panel PC

17"~19" Medical Panel PC features Intel® Core™ i7/i5/i3 mobile processor with Intel® HM55 chipset

- 17"~19" multi-functional panel PC with touchscreen
- Powered by high performance Intel® mobile Core™ i7/ i5/ i3 and Celeron® processor with Intel® HM55 chipset
- System memory supports DDR3 SDRAM SO-DIMM up to 8 GB
- HDMI interface provides second display with vivid image quality
- 802.11 a/b/g/n high speed wireless
- Dual gigabit Ethernet



### The Best Performance Grade with Intel® Mobile Core™ i7/ i5/ i3

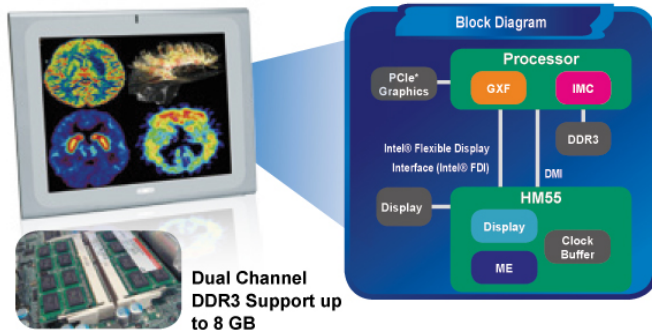

### OSD Utility

iTechLCD patented system software utility allows users to adjust system settings through the software interface in Windows environment instead of pressing the membrane keypad below the front panel.

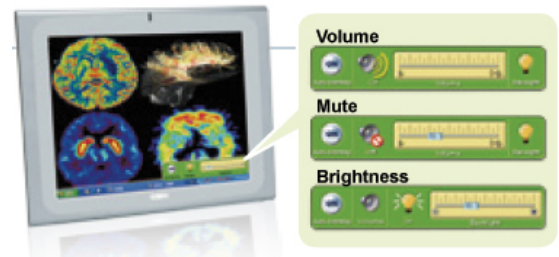

### 802.11 a/b/g/n ready with invisible antenna

The iMC1700/1900 series systems have two Gigabit Ethernet LAN connectors and wireless 802.11 a/b/g/n network connections, enabling better link quality through accurate network selection. The powerful 802.11 a/b/g/n wireless connection increases redundancy and ensures reliable network for real-time medical record processing.

27 times faster than 802.11b,  
no cables or installation fees

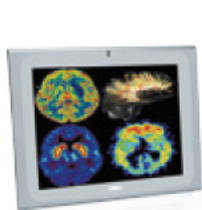

	802.11a	802.11b	802.11g	802.11n
Data Rate (Mbps)	54	11	54	540
Range (Radius Indoor)	35 Meters	38 Meters	38 Meters	250 Meters
Range (Radius Outdoor)	120 Meters	140 Meters	140 Meters	250 Meters
Radio Frequency	5.15 GHz to 5.85 GHz	2.4 GHz to 2.5 GHz	2.4 GHz to 2.5 GHz	2.4 GHz or 5.0 GHz

## Specification

Model		iMC1700	iMC1900
LCD Touch Specification	LCD size (inch)	17"	19"
	Max Resolution	1280 (W) x 1024 (H)	
	Brightness (cd/m <sup>2</sup> )	380	350
	Contrast Ratio	800:1	1000:1
	LCD Color	16.7M	
	Viewing Angle (H-V)	170/160	
	Touch Screen	Resistive Type 5-Wire	
System	CPU	Socket G (PGA989A) Intel® Arrandale processor Core™ i7-620M 2.66G / Core™ i5-520M 2.4G / Core™ i3-350M 2.26G / Celeron® P4500 1.86G	
	Chipset	Intel® HM55	
	Memory	Two 204-pin 800/ 1066 MHz DDR3 dual-channel SO-DIMM (system max. 8GB)	
	I/O Ports	1 x RS-232 by DB-9 2 x GbE LAN by RJ-45 1 x HDMI Port 1 x VGA port by DB-15 1 x Power switch	1 x RS-232 or RS-422/485 by DB-9 4 x USB connector 1 x Audio jack (line out) 1 x Reset button 1 x Power jack
	Drive Bay	1 x 2.5" SATA HDD bay for SATA storage devices	
	Audio	AMP 3W + 3W (internal speaker)	
	Membrane Keypad	LCD on/off, Brightness up/down, Volume up/down	
	LED Function	1 x Power on/off LED on front panel	
Wireless	Wi-Fi	1 x Wi-Fi module 802.11 a/b/g/n (internal PCIe Mini card interface)	
Physical	Construction Material	anti-bacteria Plastic front frame	
	Mounting	Panel, Wall, Rack, Stand and Arm VESA 100mm x 100mm	Panel, Wall, Stand and Arm VESA 100mm x 100mm
	Net Weight	6.0 kg	6.2 kg
	Dimensions (WxHxD) (mm)	428 x 350 x 76	470 x 383 x 79
Environment	Operation Temperature (°C)	0°C~50°C	
	Storage Temperature (°C)	-20°C~60°C	
	IP Level	Front Frame IP64	
Power	Power Requirement	12V DC	

## I/O Interface

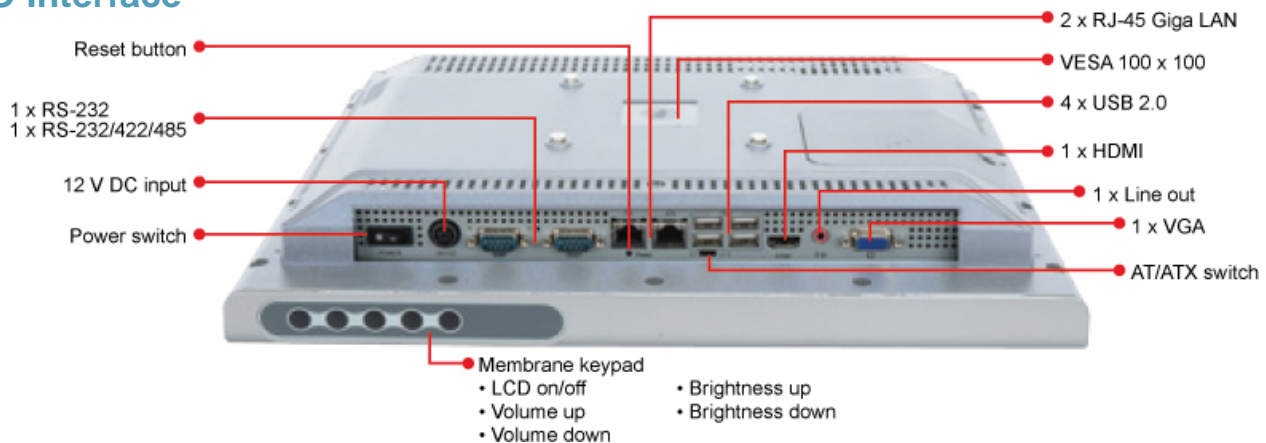

Dimensions (Unit: mm)

iMC1700

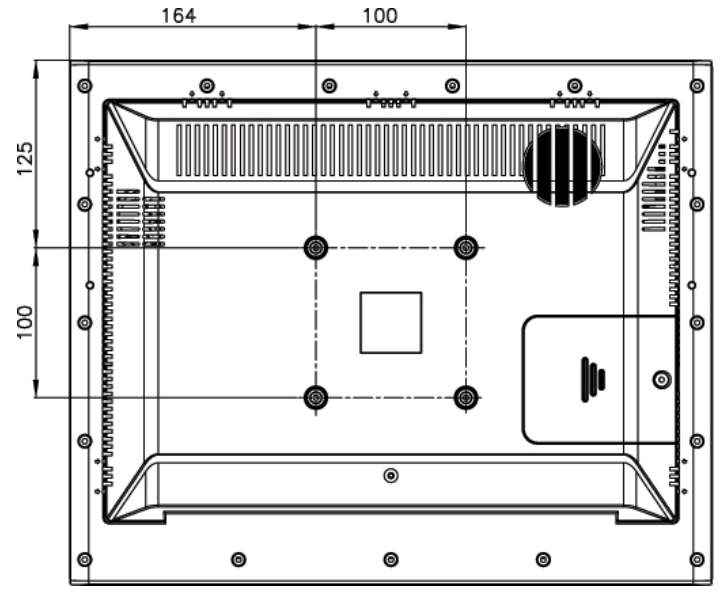
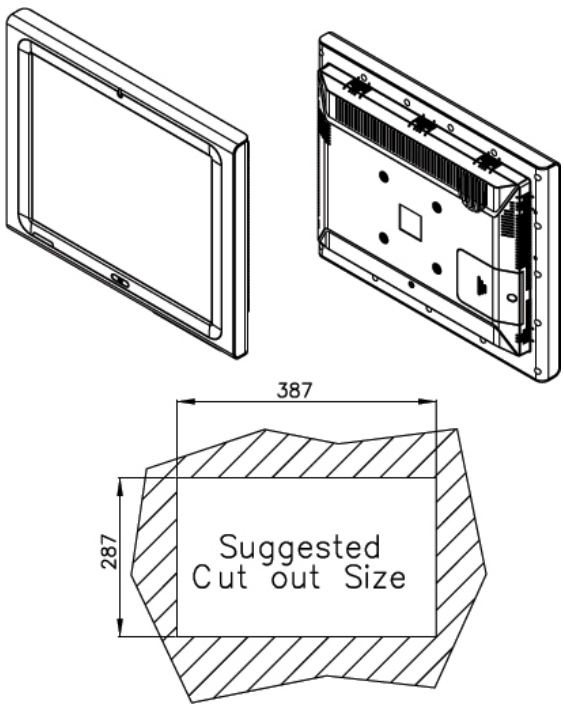
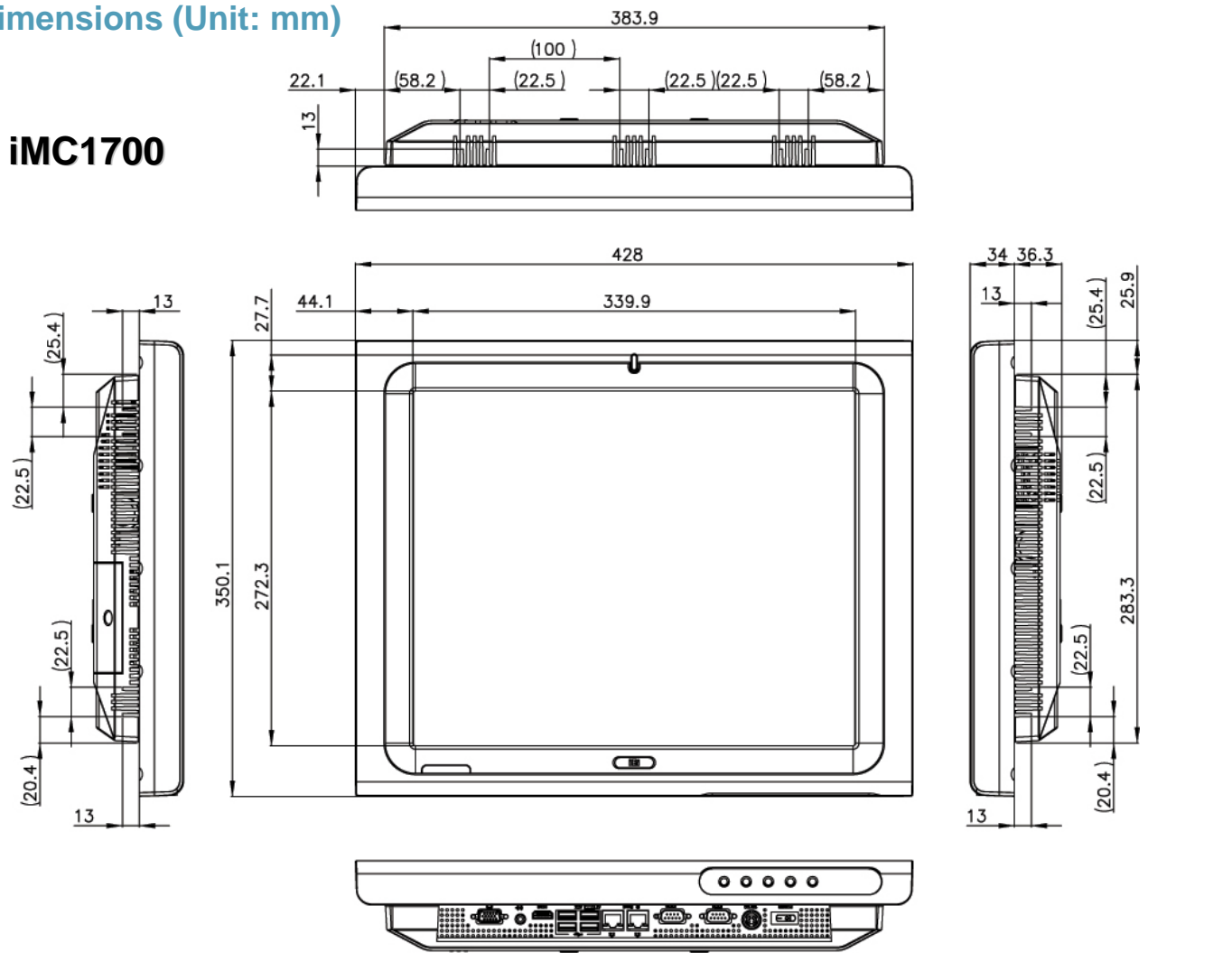

# Dimensions (Unit: mm)

## iMC1900

