

Model	Dimension A		Dimension B	Dimension C
	Height (mm)	Height (U unit)	Width (mm)	Depth (mm)
WOF816	283.9	6U	510	410
WOF916	417.3	9U	510	410

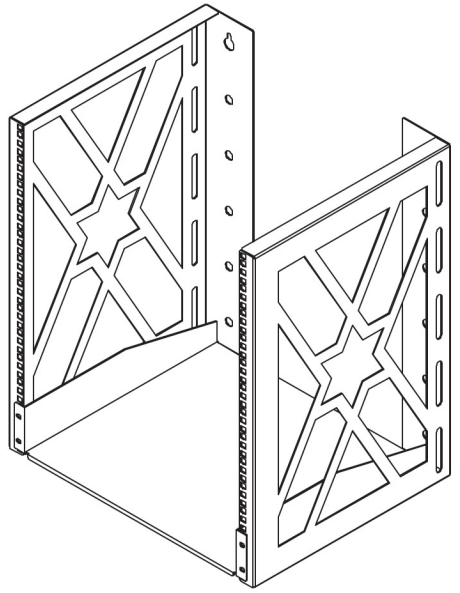

⊠15

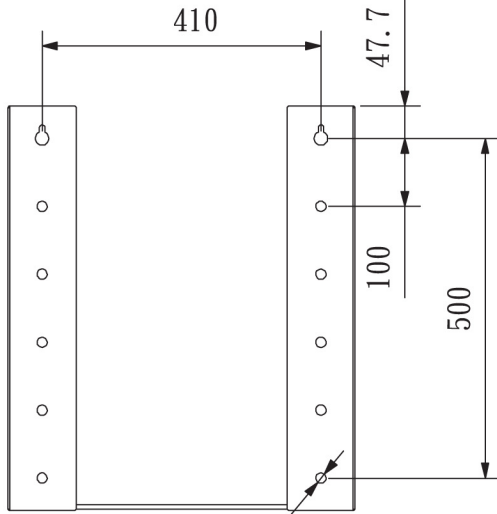
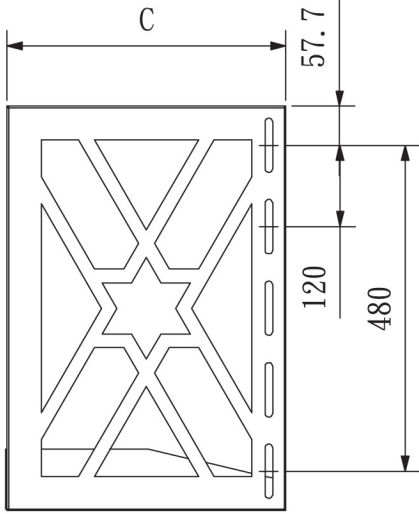
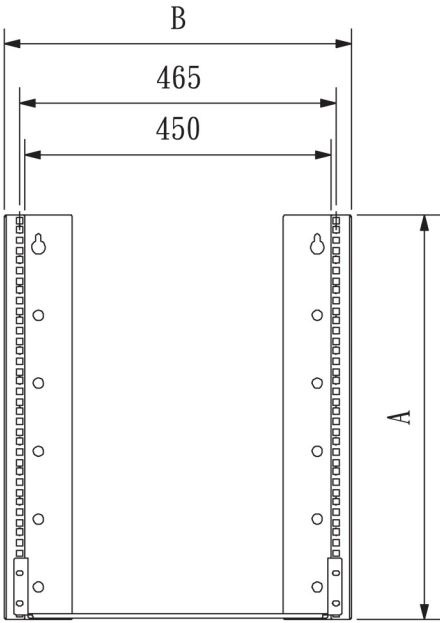
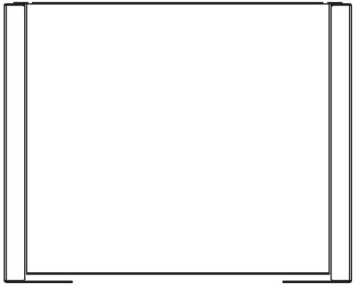
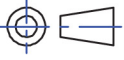

DRAWING	TYPE	MATERIAL	UNIT	m m	ORDER NO.	SALESMAN	DRAFTSMAN
DWG NO.	VER	PLATE THICK	AMOUNT	DATE	CUSTOMER	VERIFY	