

THIS IS AN ELECTRONICALLY CONTROLLED AND ISSUED DOCUMENT. HARD COPY DOCUMENTS MUST BE VERIFIED AGAINST ELECTRONIC REVISION PRIOR TO USE.

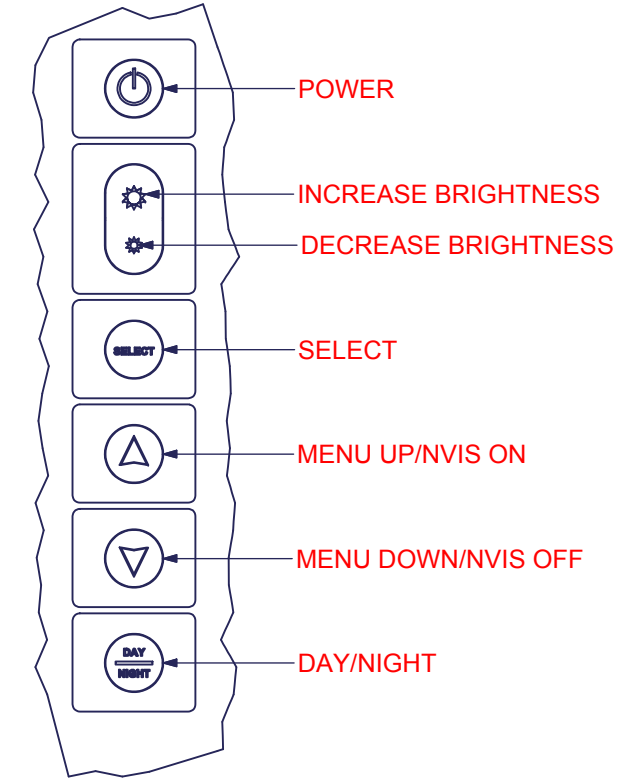

DETAIL A
USER INTERFACE BUTTONS

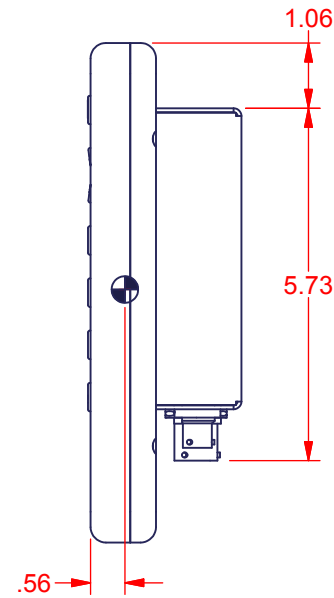
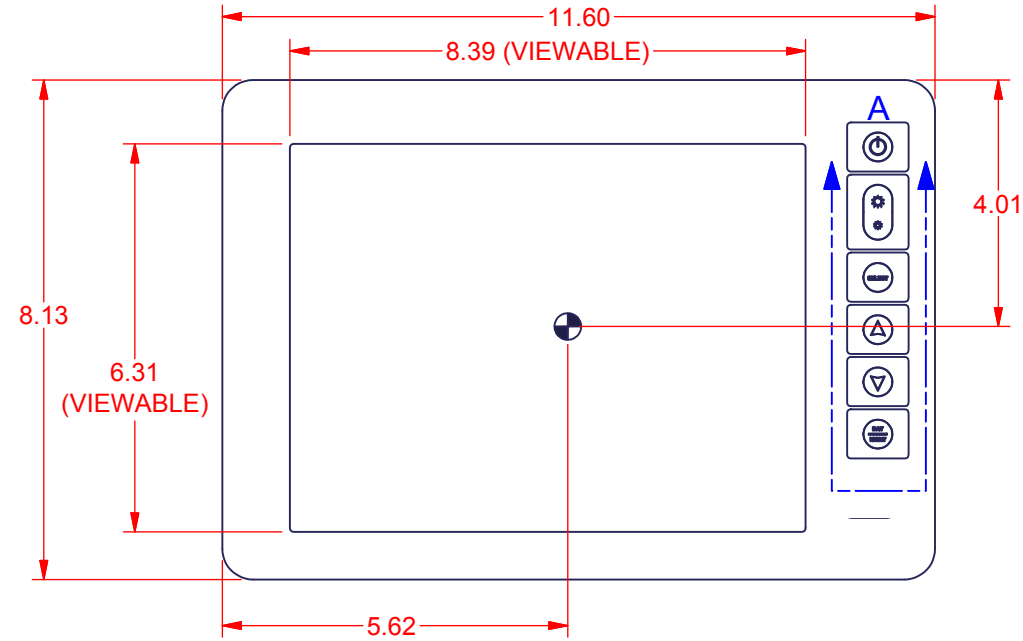
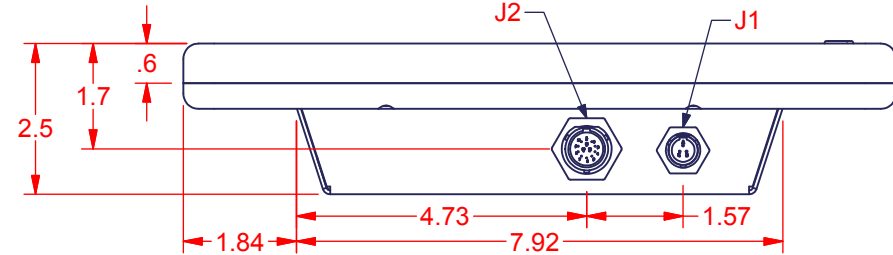

10-32 UNF - 2B ∇ .150
MAX TORQUE 24 in-lbs.

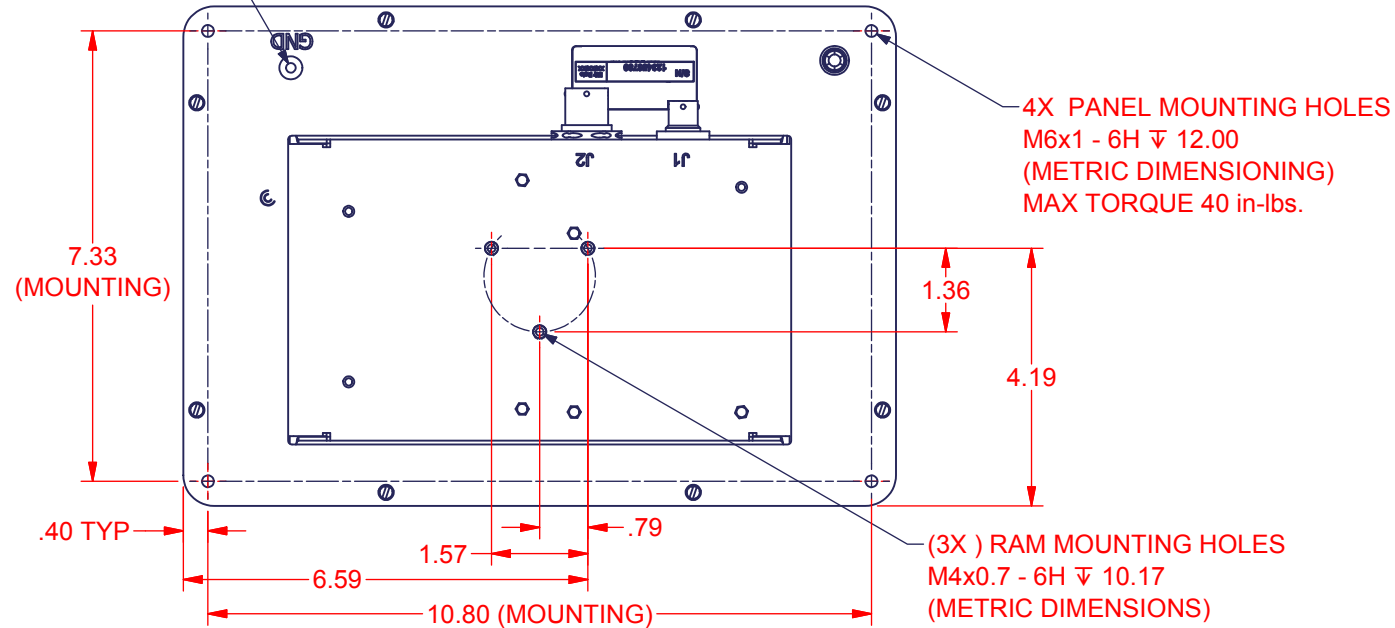

4X PANEL MOUNTING HOLES
M6x1 - 6H ∇ 12.00
(METRIC DIMENSIONING)
MAX TORQUE 40 in-lbs.

(3X) RAM MOUNTING HOLES
M4x0.7 - 6H ∇ 10.17
(METRIC DIMENSIONS)

**POWER 3 PIN RECEPTACLE
MIL-DTL-26482 SERIES I CONNECTOR**

PIN	SIGNAL
A	28 VOLT DC
B	28 VOLT RTN
C	N/C

AMPHENOL #	71-533721-33P (3-pin power)
Mate #	PT06E833SSR (141247)
Strain #	Included

**RGB 13 PIN RECEPTACLE
MIL-DTL-38999 SERIES I CONNECTOR**

PIN	SIGNAL
1	Red Video Signal
2	Red Video Ground
3	Green Video Signal
4	Green Video Ground
5	Blue Video Signal
6	Blue Video Ground
7	H-SNYC
8	V-SNYC
9	H/V SYNC Ground
10	USB+/RS-232 RXD
11	USB-/RS-232 TXD
12	Digital Ground
13	RI-OUT

AMPHENOL #	88-569722-35P (Video Only)
Mate #	MS27467E11B35S (141238)
Strain #	M85049/49-2-10W (141248)

EXPORT CONTROL -- THIS DOCUMENT IS CONTROLLED TO DSE. THE INFORMATION CONTAINED IN THIS DOCUMENT PERTAINS TO A DEFENSE ARTICLE CONTROLLED FOR EXPORT BY THE INTERNATIONAL TRAFFIC IN ARMS REGULATIONS (ITAR). DSE TRADE SECRETS CONTAINED HEREIN ARE SUBJECT TO DISCLOSURE RESTRICTIONS AS A MATTER OF LAW. DIVERSION CONTRARY TO US LAW IS PROHIBITED. US DEPARTMENT OF STATE AUTHORIZATION IS REQUIRED PRIOR TO EXPORT OR TRANSFER TO FOREIGN PERSONS OR PARTIES."

PROPRIETARY NOTICE -- PERMISSION IS HEREBY GRANTED TO USE THE CONFIDENTIAL INFORMATION ON THIS DOCUMENT FOR REFERENCE ONLY AND MAY NOT BE PRODUCED OR DISCLOSED TO OTHERS WITHOUT PRIOR WRITTEN PERMISSION OF DIGITAL SYSTEMS ENGINEERING (DSE).

TOLERANCES

LINEAR .X = \pm .1	ANGULAR \pm .5°
.XX = \pm .01	
.XXX = \pm .005	

UNLESS OTHERWISE SPECIFIED
DIMENSIONS ARE IN INCHES

Project: **DMM10400R-HB**
Status: Released

Design: JE Date: 6/15/2011
Check: EC Date: 6/24/2011

Part/Dwg #: **DMM10400R-HB, Display**

Rev # **1.5**

Wgt: 4.50 \pm .25lbs.

OVERVIEW
OVERVIEW, DISPLAY ASSY

Sheet 1 of 1

i-Tech Company LLC

Phone: (888) 483-2418 Email: info@itechlcd.com
Web: www.iTechLCD.com