

User Manual

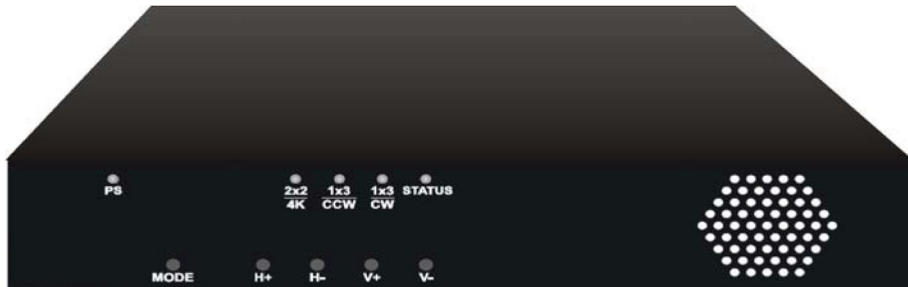

AVW220H Crescent Walls 2x2 / 3x3 / 4x4



i-Tech Company LLC

TOLL FREE: (888) 483-2418 • EMAIL: info@iTechLCD.com • WEB: www.iTechLCD.com

COPYRIGHT AND TRADEMARKS

All rights reserved by iTech Company LLC. No part of this document may be reproduced in any form or by any means without written permission from the product manufacturer. Changes are periodically made to the information in this document. They will be incorporated in subsequent editions. The product manufacturer may make improvements and /or changes in the product described in this document at any time.

All the registered trademarks referred to this manual are belonging to their respective companies.

BEFORE YOU BEGIN

- Follow all instructions marked on the device during using.
- Provide proper ventilation and air circulation and do not use near water.
- It is better to keep it in a dry environment.
- Place the device on a stable surface (example cart, stand, table, etc.).
- The system should be installed indoor only. Install either on a sturdy rack or desk in a well-ventilated place.
- Make sure the rack is level and stable before extending a device from the rack if necessary.
- Make sure all equipments installed on the rack including power strips and other electrical connectors are properly grounded.
- Only use the power cord supported with the device.
- Do not use liquid or aerosol cleaners to clean the device.
- Always unplug the power to the device before cleaning.
- Unplug the power cord during lightning or after a prolonged period of non-use to avoid damage to the equipment.
- Do not stand on any device while installing the device to the rack.
- Do not attempt to maintain the device by yourself, any faults, please contact your vendor.
- Save this manual properly for future reference.

TABLE OF CONTENTS

Copyright and Trademarks.....	1
Before You Begin	2
Table of Contents.....	3
List of Figures.....	5
Chapter 1 Overview.....	7
1.1 Introduction.....	7
1.2 Packing.....	8
1.3 Accessories (Optional).....	8
1.4 Applications	8
Chapter 2 Features	9
Chapter 3 Specifications.....	10
Chapter 4 Installation	11
Chapter 5 Front/Rear Panels.....	12
5.1 Front Panel.....	12
5.2 Rear Panel.....	13
5.2.1 HDMI Output Connector	15
5.2.2 Wiring Information for LAN Connector	15
Chapter 6 Connections.....	16
6.1 Input Connection.....	19
6.2 Output Connection	19
6.2.1 HDBaseT Output Port.....	20
6.2.2 Output Cable	21
6.3 Power Connection	22
Chapter 7 Web Interface Configuration	23
7.1 Setup	24
7.1.1 Monitor Arrangements and Settings	25
7.1.2 Mullion Adjustments	28
7.1.3 Offset and Zoom Settings.....	29
7.1.4 Color Settings.....	29
7.2 Advance	32
7.3 Administration.....	33
7.3.1 Username	33
7.3.2 Password	33
7.3.3 Network	34
Chapter 8 Troubleshooting.....	35
Appendix A Extender (Optional).....	36
Extender Connection	36

Appendix B Video Wall Configuration.....	37
2x2 Mode.....	38
3x3 Mode.....	41
4x4 Mode.....	41
1x3 CW Mode.....	42
1x3 CCW Mode.....	42
Landscape 1x3 A/B/C Mode.....	43
3x4 Mode A / 3x4 Mode B.....	45
2x3 Mode A / 2x3 Mode B.....	46
2x8 CW / 2x8 CCW.....	47

LIST OF FIGURES

Figure 1: AVW220H.....	7
Figure 2: Mount AVW Series on a Standard Bracket with 1U Rack-mount	11
Figure 3: Place the device on a sturdy surface	11
Figure 4: Mount the device in the rack	11
Figure 5: AVW220H Front Panel.....	12
Figure 8: AVW220H Rear Panel	13
Figure 14: HDMI Output Connector	15
Figure 15: LAN Connector.....	15
Figure 16: AVW220H Connections.....	16
Figure 22: Input Connection	19
Figure 23: Output Connection with HDMI Interface.....	19
Figure 24: Output Connection with RJ-45 Interface	20
Figure 25: LAN (HDBT) Port Pin Definition.....	20
Figure 26: Output Cable.....	21
Figure 27: Power Connection.....	22
Figure 28: Web Control Address.....	23
Figure 29: Web Control - Login.....	23
Figure 30: Web Control - Setup	24
Figure 31: Wall Board.....	25
Figure 32: Wall Modes.....	26
Figure 33: Output Resolution	27
Figure 34: Output Modes	27
Figure 35: Mullion Adjustment.....	28
Figure 36: Mullion Adjustment Compensation.....	28

Figure 37: Color Settings	29
Figure 38: Output Port Color Temperature.....	30
Figure 39: Common Color Temperature.....	30
Figure 40: Color Temperature Bar.....	30
Figure 41: RGB Adjustment.....	31
Figure 42: Web Control - Advance	32
Figure 43: Web Control - Administration	33
Figure 44: Extender	36
Figure 45: Extender Connection.....	36
Figure 47: 2x2 Mode Status 1	38
Figure 48: 2x2 Mode Status 2	39
Figure 49: 2x2 Mode Status 3	40
Figure 50: 3x3 Mode.....	41
Figure 51: 4x4 Mode.....	41
Figure 52: 1x3 CW Mode	42
Figure 53: 1x3 CCW Mode	42
Figure 54: Landscape 1x3 A Mode.....	43
Figure 55: Landscape 1x3 B Mode	43
Figure 56: Landscape 1x3 C Mode.....	44
Figure 57: 3x4 Mode A	45
Figure 58: 3x4 Mode B.....	45
Figure 59: 2x3 Mode A	46
Figure 60: 2x3 Mode B.....	46
Figure 61: 2X8 CW Mode	47
Figure 62: 2X8 CCW Mode	47

CHAPTER 1 OVERVIEW

1.1 Introduction

The crescent walls is a video wall consists of multiples monitors (2x2 / 3x3 / 4x4) lied together contiguously or overlapped in order to form one large screen. Use typical display technologies and mullion compensation with seamless output feature.

For the video display orientation configuration, the crescent walls allow you to configure the video with landscape mode – a widescreen landscape display mode. The output picture will adjust the aspect ratio to available display size automatically. The picture will not be deformed due to a rotation.

Moreover, while color temperature dramatically affects the picture qualities of an LCD monitor. User can simply use the default values to restore the picture basic quality. A good understanding of the meaning of color temperature will enable better adjustments of LCD monitor picture quality.

Through the HDBT (AVW220H) interfaces you can optional select output transmission mode featuring a high resolution and low energy consumption. Typical application areas of the crescent walls include information displays, digital advertisings, meeting rooms and so on.

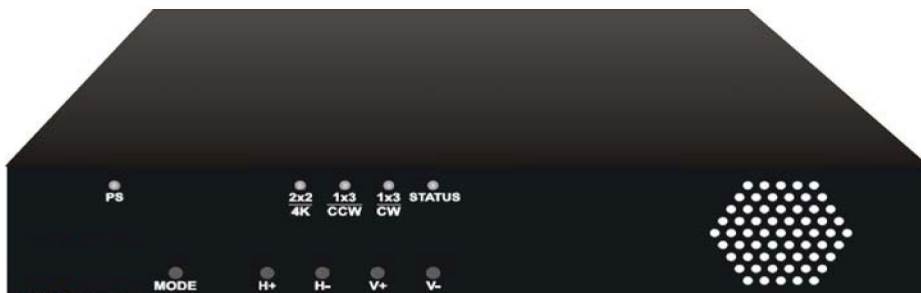







Figure 1: AVW220H

1.2 Packing

	AVW220H x 1
	Power Cord x 1
	Rack-Mount Bracket x 2
	Screws (for Brackets) x 6
	CD User Manual x 1

1.3 Accessories (Optional)

	HDMI Remote Extender
---	----------------------

1.4 Applications

Video Walls can be used to display information for:

- Public and Emergency Services
- Intelligent Traffic Systems
- Surveillance and Security
- Telecommunications
- Power and Utilities
- Data Monitoring
- Broadcast
- Defense
- Energy

CHAPTER 2 FEATURES

- Crescent Video Wall can be configured as 2x2 / 3x3 / 4x4
- Mullian compensation
- Color temperature adjustments
- Can be configured landscape mode to be used as video walls (with mullion compensation).
- Supports 1 HDMI connector for output display identical image on local side
- Option HDBT or HDMI output
 - Supports 1 HDMI connector for input and 4/12/16 RJ-45 connectors for HDBaseT output interfaces
 - Supports 1 HDMI connector for input and 4/12/16 HDMI connectors for HDMI output interfaces
- HDBaseT Output supports the long-distance transmission via a 70m Cat.5e cable
- Supports HEMI Remote Extender (Optional)
- Supports resolution up to 1080P for each Crescent Video Wall
- Internal universal power supply
- 1U rack design.

CHAPTER 3 SPECIFICATIONS

Hardware	
Input Connector	HDMI Type A Female: - AVW220H x 1
Output Connector (Local)	HDMI Type A Female (Local Video Output): - AVW220H x 1
Output Connector (Remote)	RJ-45 Connector: - AVW220H: RJ-45 x 4 HDMI Connector: - AVW220H: RJ-45 x 4
IP Port	RJ-45 IP Port x 1
Power	100VAC~240VAC, 50/60Hz, internal
LED Indicator (Standard HDMI Signal)	LED indicator specified for the power status x 1 LED indicators specified for the signal status:
Housing	Metal
Mounting	Rack mountable (1U-rack-mount kit)
Weight	AVW220H: g
Dimensions (LxWxH)	AVW220H:
Multimedia	
Max. Resolution	1080P / 1366 x 768 for each Crescent Video Wall
Control Information	
HDMI Cable Distance	Local: 10 meters (Max.) / Remote: 10 meters (Max.)
Cat.5e Cable Distance	70 meters (Max.) for QW-202S / 303S / 404S

CHAPTER 4 INSTALLATION

AVW220H has a black metallic housing. It can be placed on a sturdy desk directly or installed on a bracket. You can also use the rubber feet pasted on the bottom of the chassis to protect your device when you want to place the device on a working desk.

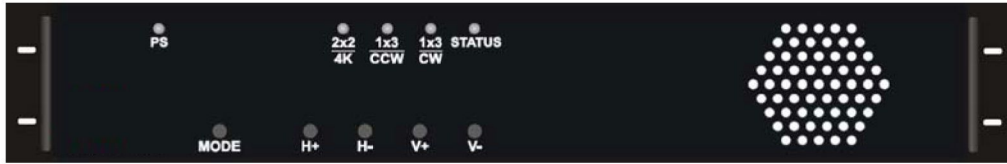

Figure 2: Mount AVW220H on a Standard Bracket with 1U Rack-mount

Attach the rubber feet to the bottom of the device, Place the device on a sturdy, level surface that can support the weight.

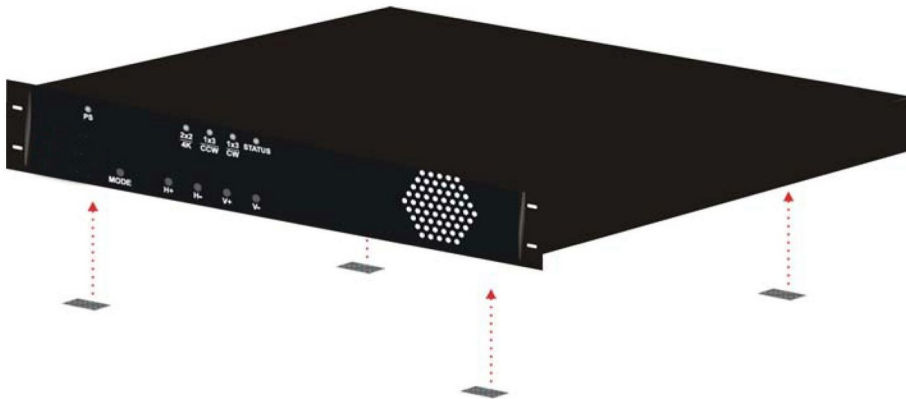

Figure 3: Place the device on a sturdy surface

Or use the screws provided with the rack and a screw driver to firmly tighten the device in the rack to prevent working lose due to vibration on the rack.

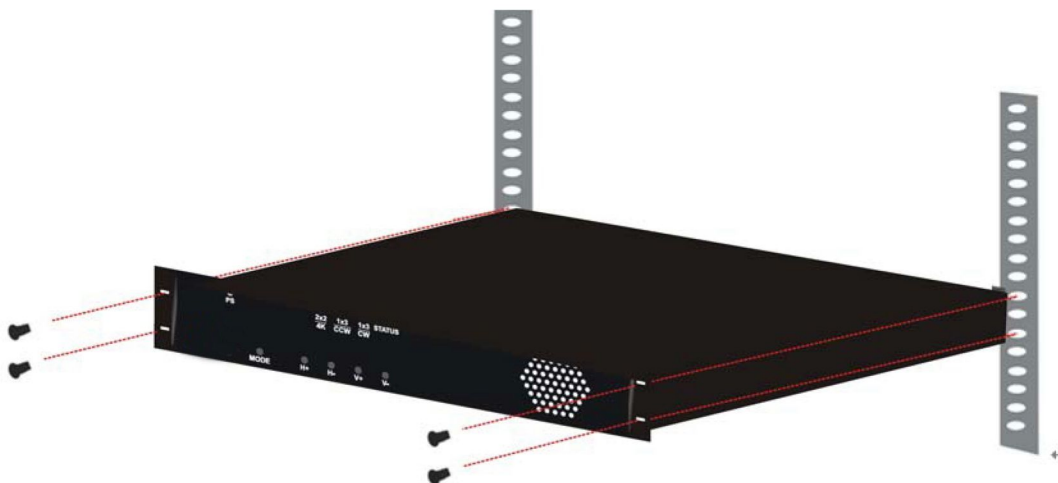

Figure 4: Mount the device in the rack

CHAPTER 5 FRONT/REAR PANELS

5.1 Front Panel

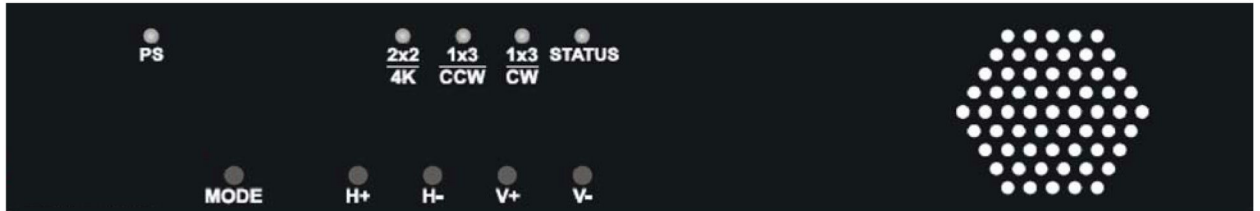

Figure 5: AVW220H Front Panel

The AVW220H support a clear LED indicator designed for the status of the power and four LED indicators designed for the signal status. Use the rotary knobs on the front panel that you can configure the QW Series without using any software interface.

- **MODE:** For AVW220H, you can use the **MODE** button to select the wall mode.
- **H+ / H- / V+ / V-:** Use the rotary knobs labeled **H+**, **H-**, **V+** or **V-** on the front panel to adjust the Mullion compensation of the output image.
- **PS LED indicator:** Show you the power status. (Green = valid, Red = invalid)
- **2x2 4K / 1x3 CCW / 1x3 CW / STATUS LED indicators:** Output signal status indicator. (Green = valid, Red = invalid)
- **1.1~3.4 or 4.4 LED indicators:** Output signal status indicator. (Green = valid, Red = invalid)

5.2 Rear Panel

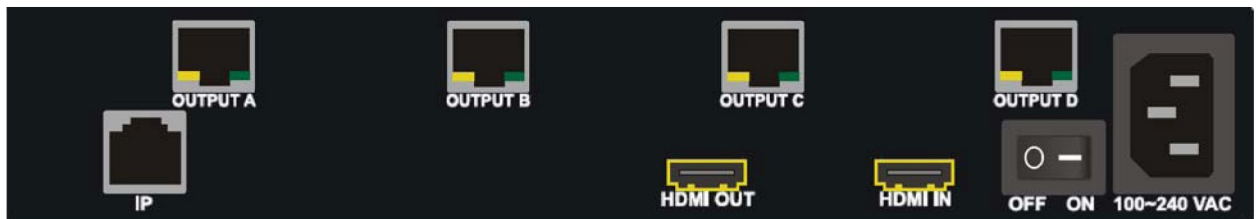

Figure 8: AVW220H Rear Panel

AVW220H Series support up to 4/12/16 output jacks (RJ-45 for AVW220H) on the rear panel, each female terminal separately form the output jacks. AVW Series terminal channels numbered as OUTPUT x are for signals output. The input interface with “HDMI IN” jack supplies you to connect to different equipment including CD/DVD player, Blu-ray player, PS3 and so on. Another output interface with “HDMI OUT” jack allows you to connect to a local output device just as the projectors, video recorders, displayers, multiplexers and so on.

- **Power port:** The Power Port is applicable for 100~240VAC, 50~60Hz connected to the outlet of power source. Refer to [6.3 Power Connection](#).
- **Local HDMI OUT (LOOP x) jack:** This is connected to the A/V or HDTVs.
- **HDMI IN (INPUT x) jack:** This is connected to the CD/DVD player, Blu-ray player, PS3, Video Camera, STB and so on.
- **Remote RJ-45 OUT Ports (OUTPUT x) :** You can use the output jacks for over long connections via the extensible accessory devices. Refer to Appendix A Extender (Optional).
- **Remote HDMI OUT Ports (OUTPUT x) :** You can use these output jacks located on the rear panel to transmit the signals to the output displayers with a HDMI cable.
- **Power Switcher:** Switch the device on or off.
- **IP:** Connected to local PC with a RJ-45 Ethernet cable for software configuration.

5.2.1 HDMI Output Connector

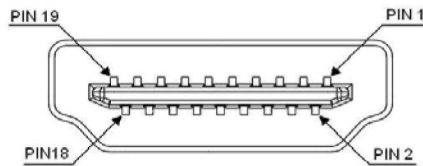

Figure 14: HDMI Output Connector

HDMI Type A Connector host assignment:

Pin #	Signal	Pin #	Signal
1	TMDS Data 2+	11	TMDS Clock Shield
2	TMDS Data 2 Shield	12	TMDS Clock -
3	TMDS Data 2-	13	NC
4	TMDS Data 1+	14	NC
5	TMDS Data 1 Shield	15	DDC SCL
6	TMDS Data 1-	16	DDC SDA
7	TMDS Data 0+	17	DDC/CEC Ground
8	TMDS Data 0 Shield	18	+5V Power
9	TMDS Data 0-	19	Hot Plug Detect
10	TMDS Clock+		

5.2.2 Wiring Information for LAN Connector

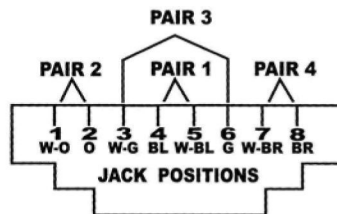

Figure 15: LAN Connector

Conductor Identification	RJ-45 Pin Assignment	Color Code for Conductor
Pair 1	5	White-Blue
	4	Blue
Pair 2	1	White-Orange
	2	Orange
Pair 3	3	White-Green
	6	Green
Pair 4	7	White-Brown
	8	Brown

CHAPTER 6 CONNECTIONS

Before making the connections, make sure all devices are powered off. Refer to the illustrated connections below and also to the user manual of the device you are connecting to the AVW Series.

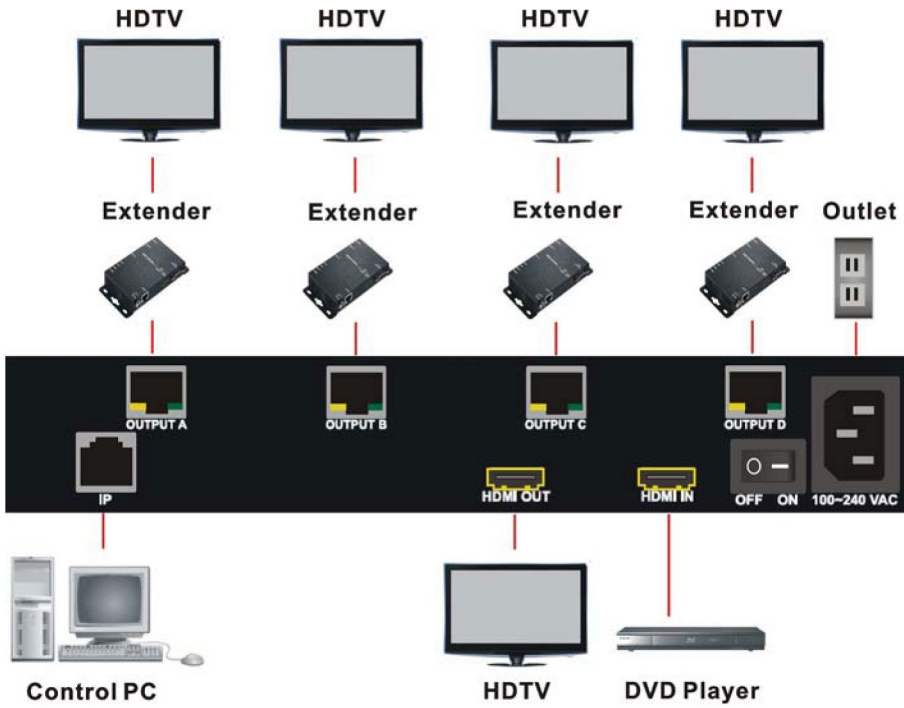

Figure 16: AVW220H Connections

6.1 Input Connection

Use the HDMI connecting cable to connect the Input serial jack (HDMI IN) to the HDMI jack of the Blu-ray/DVD player/graphics workstations/PC.

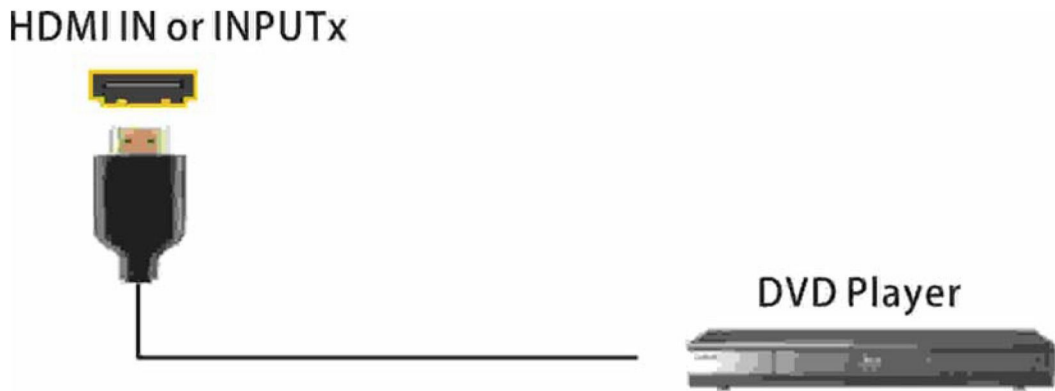

Figure 22: Input Connection

6.2 Output Connection

Use the HDMI cable to connect the output jacks on the rear panel to the input jack of the projector, video recorder, display, HD TV or multiplexer directly.

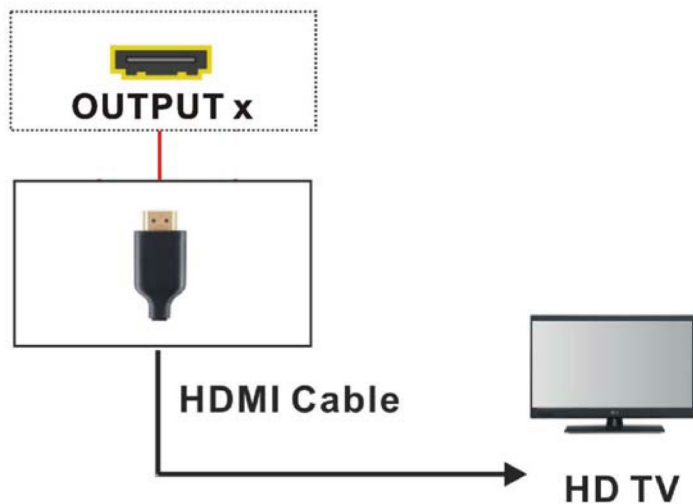

Figure 23: Output Connection with HDMI Interface

Or use the Cat.5e cable to connect the output RJ-45 jacks on the rear panel to the LINK jack of the Extender. Through the Extender, you can extend the transmission distance and over-long configuring the projector, video recorder, display or multiplexer to your Switcher.

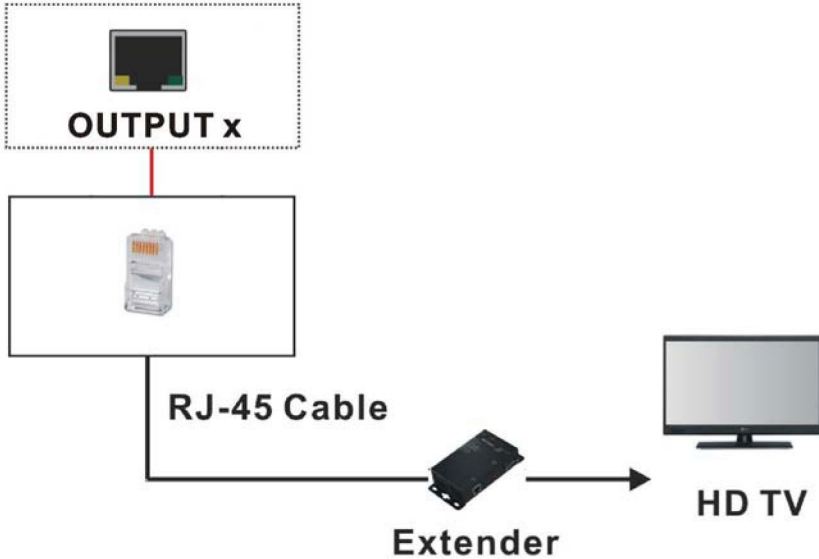

Figure 24: Output Connection with RJ-45 Interface

6.2.1 HDBaseT Output Port

QW-Series supports RJ-45 registered jacks using 8P8C modular connector, which specifies the physical male and female connectors as well as the pin assignments of the wires in a telephone cable. (A common LAN cable is available.)

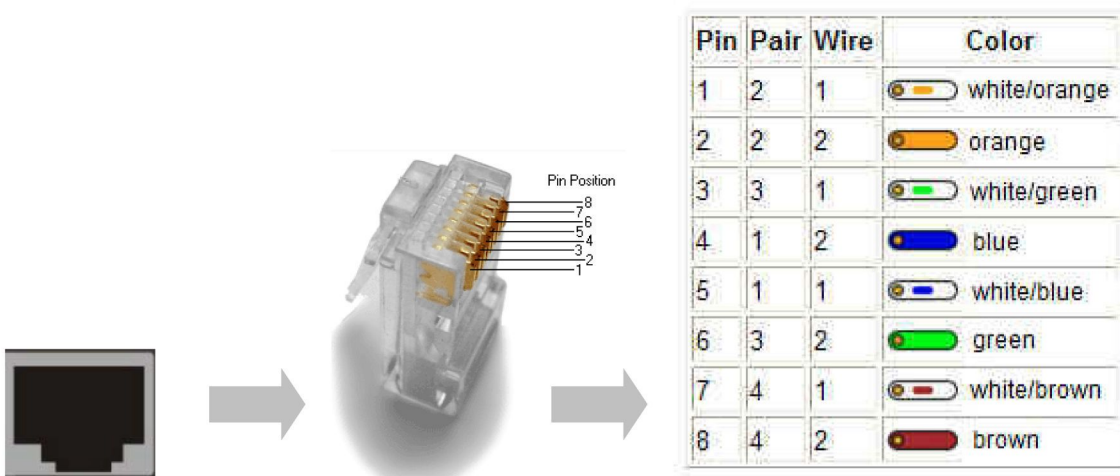

Figure 25: LAN (HDBT) Port Pin Definition

6.2.2 Output Cable

HDBaseT was designed to provide Full HD performance up to 70 meters of Cat.5e or superior cables. In a typical installation, the cable is stretched to its full length between the HDBaseT Transmitter device and the HDBaseT Receiver device. However sometimes, especially, in demonstrations or in a lab environment, the cable is rolled randomly in small turns for convenience. The randomly rolled UTP cable suffers additional signal impairments (compared to straight cable) and therefore the maximal operating reach might be reduced. When a Cat.5e cable is randomly rolled, it is recommended to limit its length to approximate 50 meters. Rolling a Cat.5e cable around a 70cm fixed diameter plastic drum has just a minor effect on the FEXT (Far End Cross Talk) when compared to a fully stretched cable.

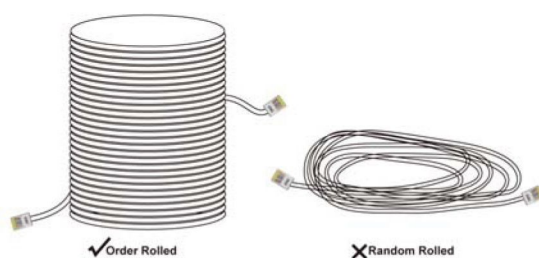

Figure 26: Output Cable

6.3 Power Connection

Use the included power cord to connect the power source from the power port on the rear panel of AVW Series to the outlet.

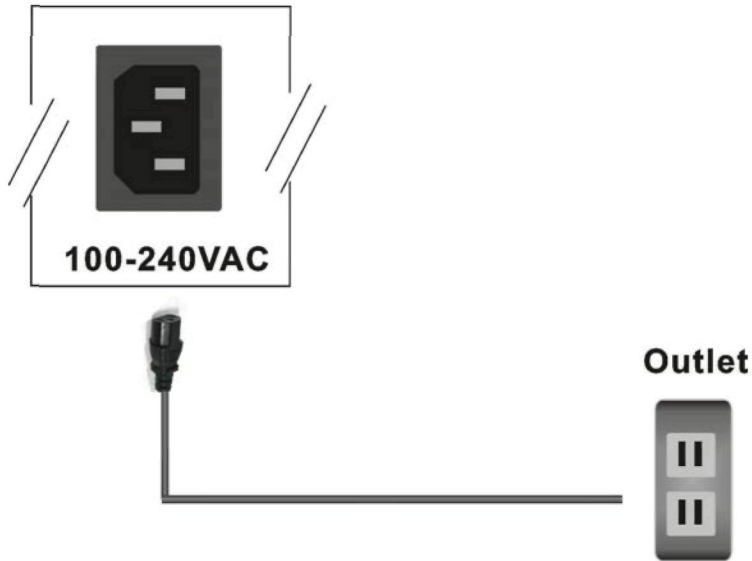

Figure 27: Power Connection

CHAPTER 7 WEB INTERFACE CONFIGURATION

Connect the “IP” port of the device to your computer or network using a standard Ethernet cable. If you connect directly to your computer, you may need to set your computer's IP address to the same subnet as the device.

The default address is **192.168.1.151**. Open a web browser and type **192.168.1.151** in the URL address line. The login page will be displayed when the connection is successfully.

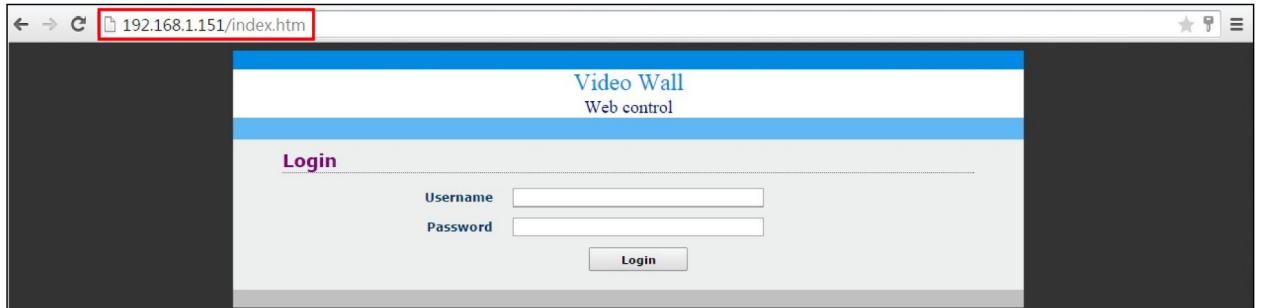

Figure 28: Web Control Address

The default username is “**admin**”, the default password is “**admin**”. The username and password are case sensitive.

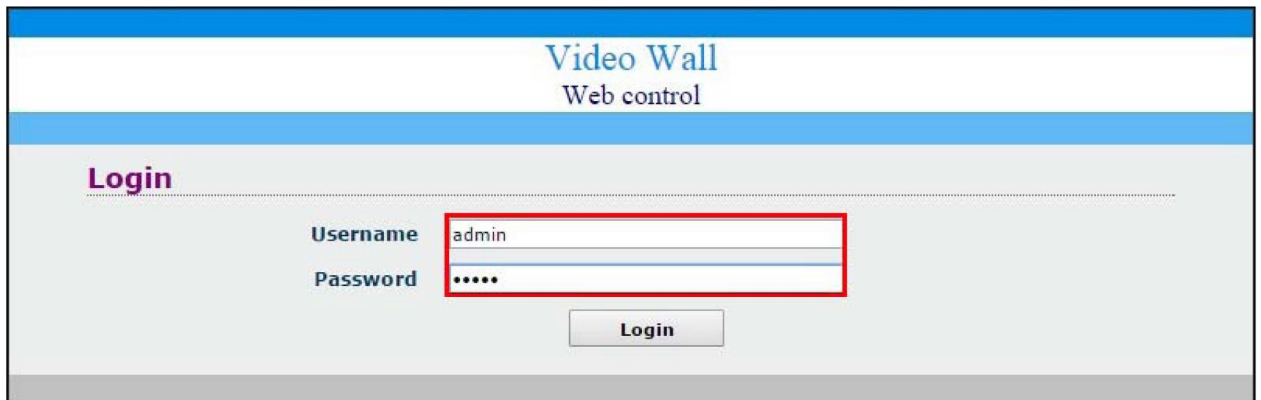

Figure 29: Web Control - Login

7.1 Setup

After you login to the built-in page, you will be able to access 3 tabs: **Setup**, **Advance** and **Administration**. Click the **Administration** tab.

The **Setup** tab page shows you the primary configurations.

Video Wall
Web control

Logout

Setup Advance Administration

Settings

Wall Boards: All boards
<All board> mode for wall 3x3 and 4x4 only

Wall Modes: 4x4

Horizontal Mullion Adjustment: pixel 0

Vertical Mullion Adjustment: line 0

1x3 Vertical Mullion Adjustment: line 0
Note: Adjustment limits may depend on display resolutions

Output Resolution: 1366x768p

Output Modes: DVI

Pre-emphasis Mode 1.1~1.4: Enable all

Pre-emphasis Mode 2.1~2.4: Enable all

Pre-emphasis Mode 3.1~3.4: Enable all

Pre-emphasis Mode 4.1~4.4: Enable all

Horizontal Offset: 0 Range (-1920~1920)

Vertical Offset: 0 Range (-1920~1920)

Horizontal Zoom(In/Out): 0 Range (-4095~4095)

Vertical Zoom(In/Out): 0 Range (-4095~4095)
Color temperature range from 1000K~25000K (100K increments)

Output Port Color Temperature: Output All

Common Color Temperature: Free

Custom Color Temperature: 6500 Unit:K

Color Space Red: 255 Range (0~255)

Color Space Green: 255 Range (0~255)

Color Space Blue: 255 Range (0~255)

Figure 30: Web Control - Setup

7.1.1 Monitor Arrangements and Settings

■ Wall Boards

Select which video wall module will be affected when the “**Apply**” button is clicked, applying the settings currently shown on the page. For more information, please refer to [Appendix B Video Wall Configuration](#).

☞ All boards mode are applied for wall 3x3 and 4x4 only.

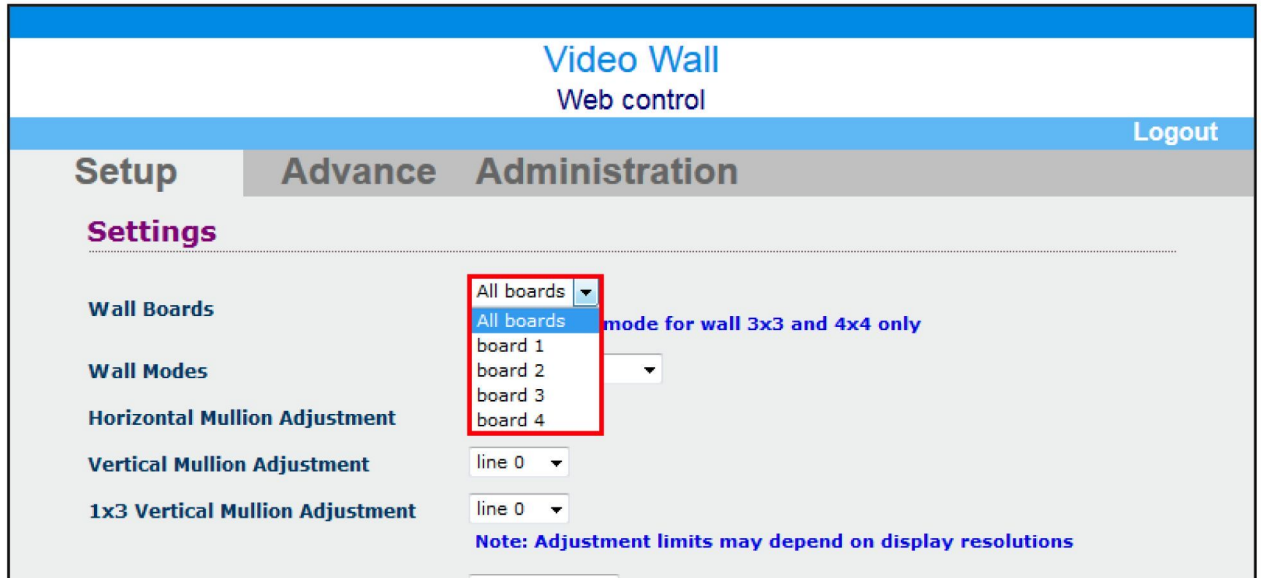

Figure 31: Wall Board

■ Wall Modes

Select the video wall monitor arrangement. This determines how the input image is split and which outputs are driven with which piece of the input image.

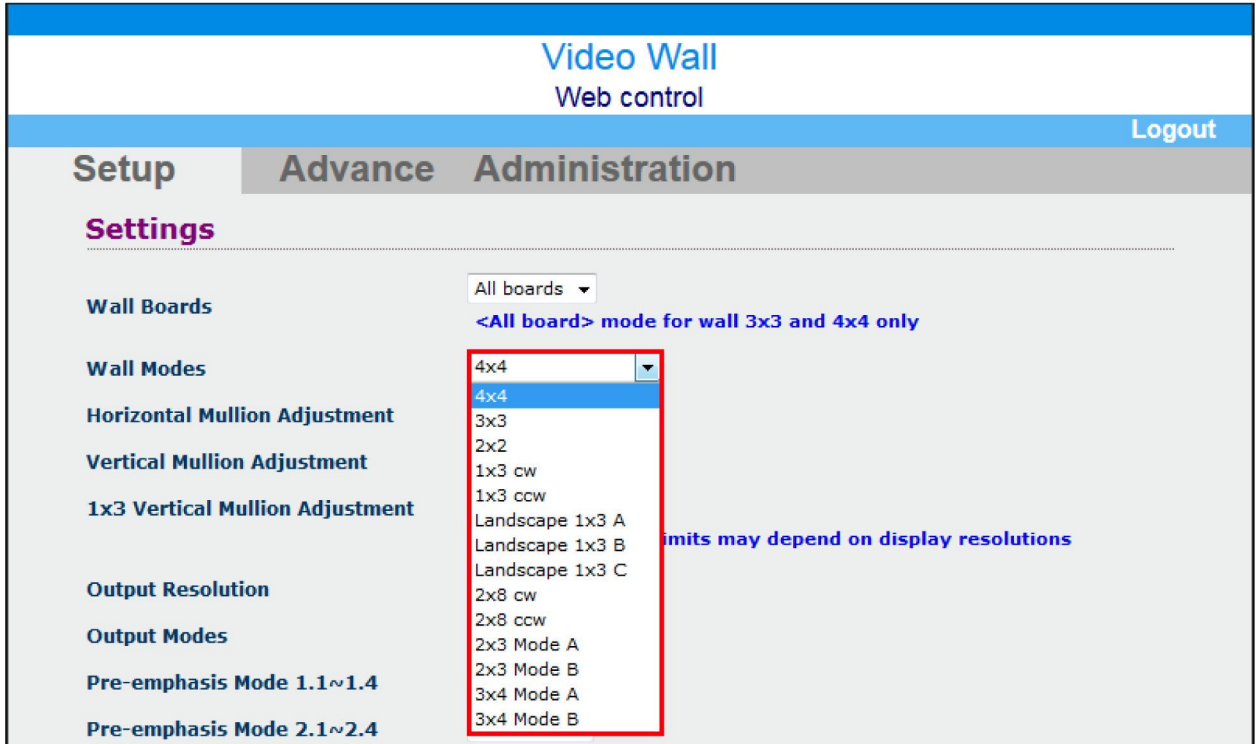

Figure 32: Wall Modes

Wall Modes values:

2x2, 1x3 cw, 1x3 ccw, Landscape 1x3 A, Landscape 1x3 B and Landscape 1x3 C.

- **Output Resolution**

Set the resolution of the output ports. Adjust this setting to match your video wall monitor's capability. The QW Series support both 1920x1080p and 1366x768p output Resolutions. The default value is **1920x1080p**.

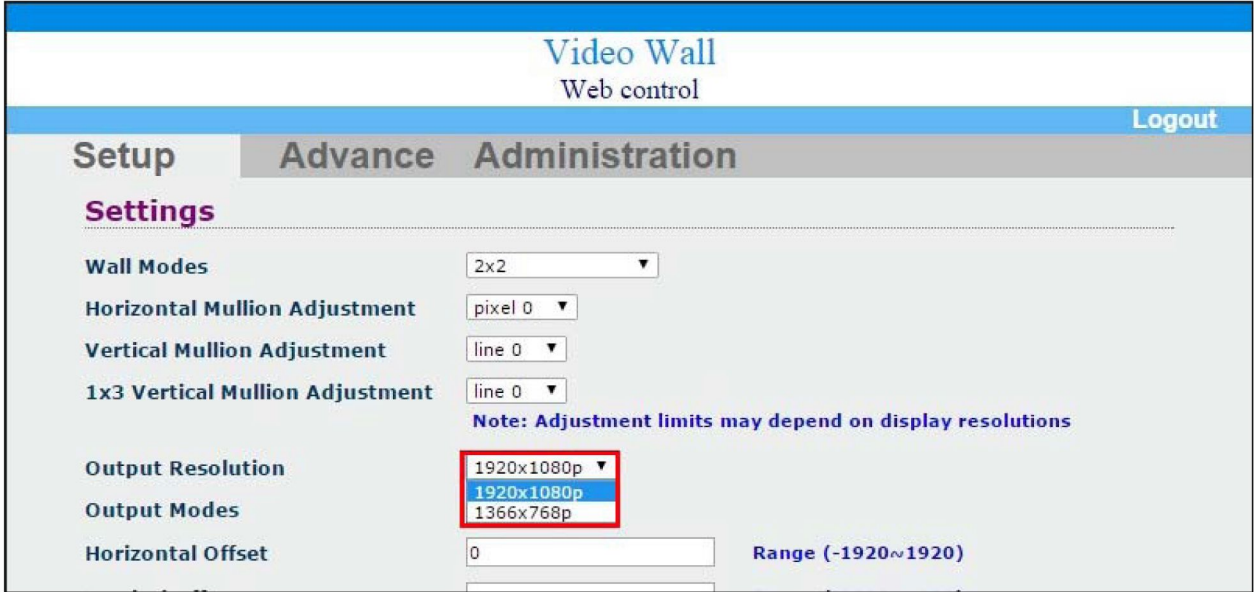

Figure 33: Output Resolution

- **Output Modes**

Select for either HDMI or DVI type video signal. Adjust this setting to match your video wall monitor's capability. The default value is either **DVI** or **HDMI** based on the connection interface.

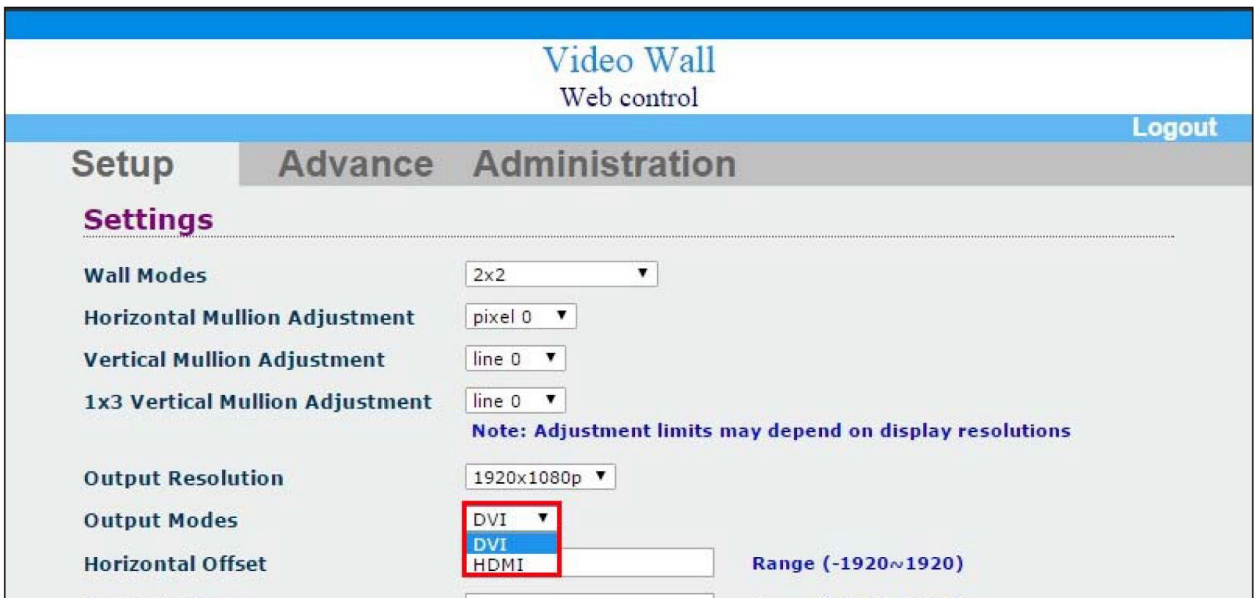

Figure 34: Output Modes

7.1.2 Mullion Adjustments

☞ Adjustment limits may depend on display resolutions.

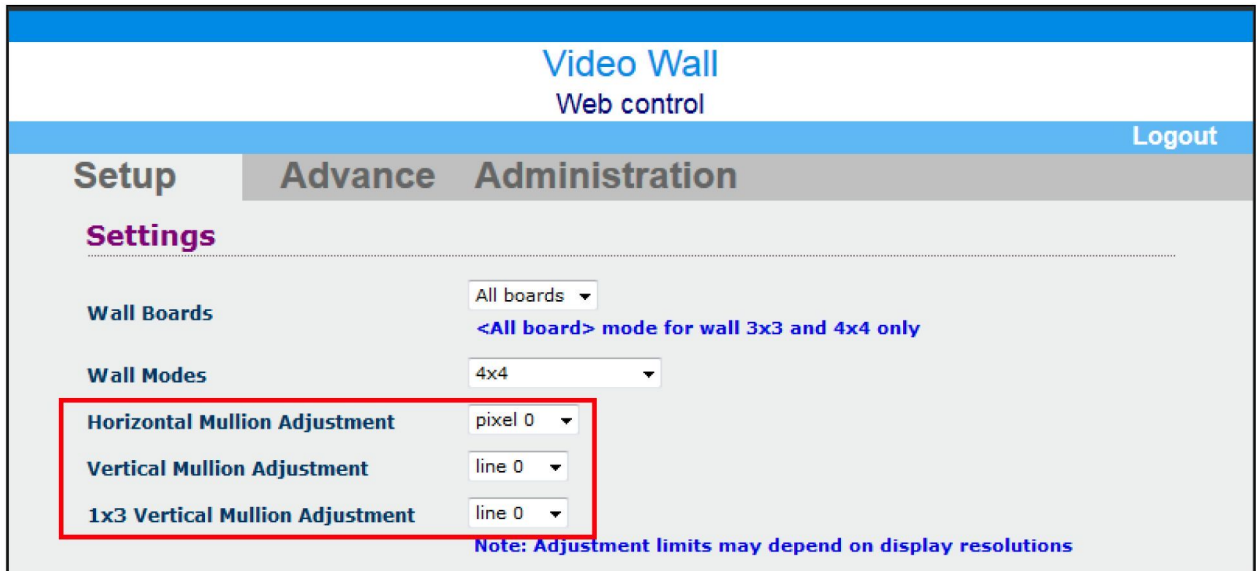

Figure 35: Mullion Adjustment

Mullion adjustments compensate for the width of the monitor's frame.

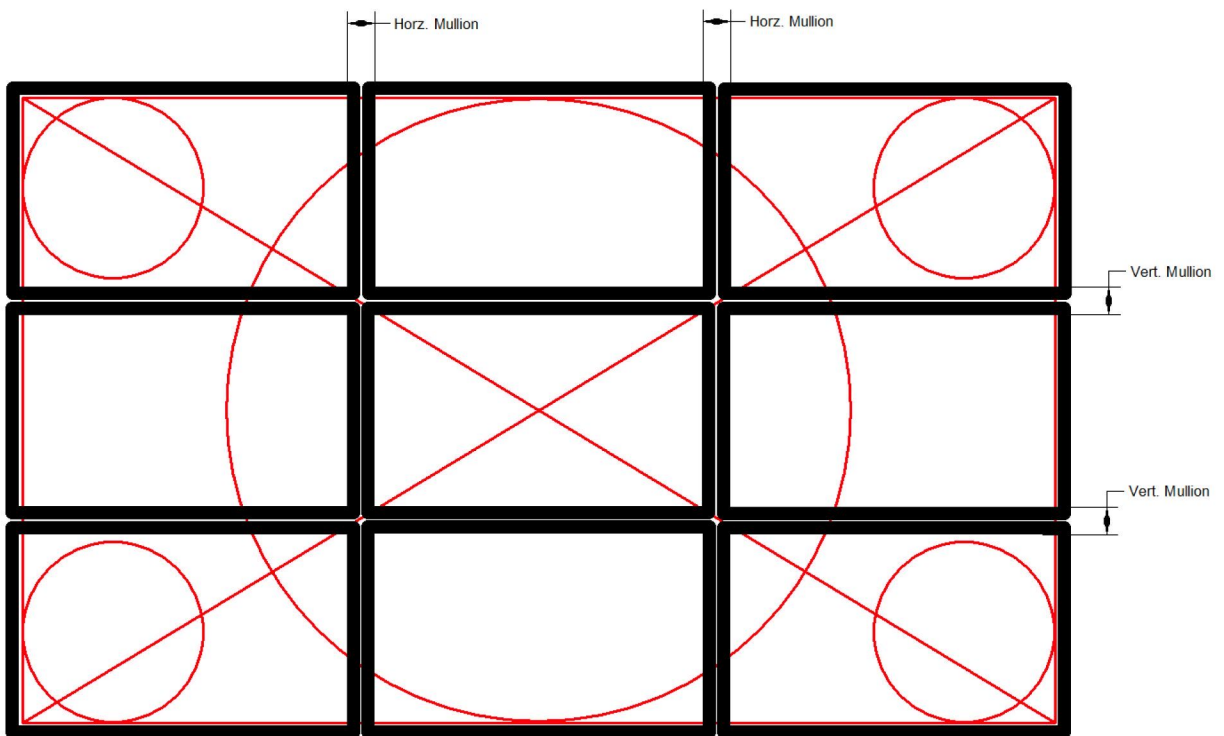

Figure 36: Mullion Adjustment Compensation

- **Horizontal Mullion Adjustment**

Select the width of the portion of image to be removed, in pixels. (The value is from pixel 0 to pixel 36)

- **Vertical Mullion Adjustment**

Select the height of the portion of image to be removed, in video lines. (The value is from line 0 to line 36)

- **1x3 Vertical Mullion Adjustment**

Select the width of the portion of image to be removed, in lines. This setting is also in line since the monitors will be in “**portrait**” mode. (The value is from line 0 to line 36)

7.1.3 Offset and Zoom Settings

These settings effectively crop and position the input image relative to the video wall.

- **Horizontal Offset:** The range is -1920~1920.
- **Vertical Offset:** The range is -1920~1920.
- **Horizontal Zoom (In/Out):** The range is -1920~1920.
- **Vertical Zoom (In/Out):** The range is -1920~1920.

7.1.4 Color Settings

These settings can adjust the output video color, either to all monitors, or to individual monitors to compensate for disparate monitors.

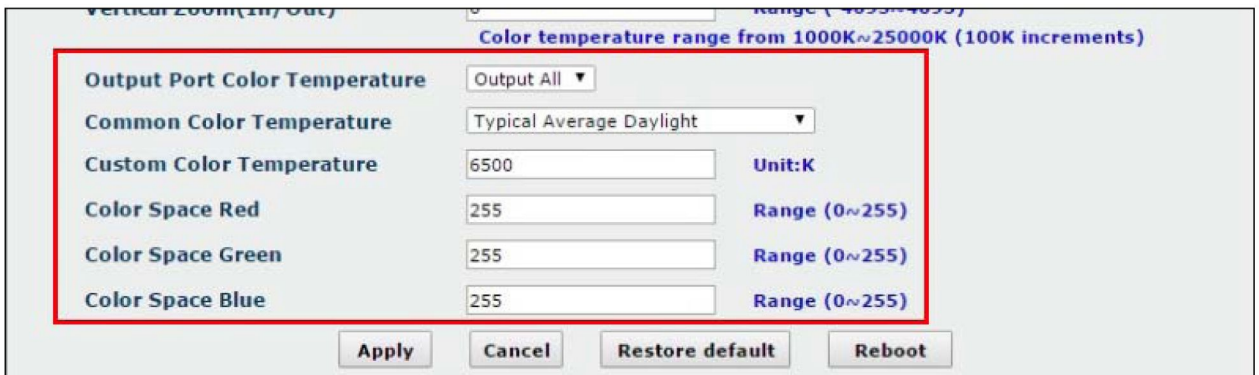

Figure 37: Color Settings

- **Output Port Color Temperature**

Select which output ports are affected by the settings when the “**Apply**” button is clicked. The default value is **Output All**.

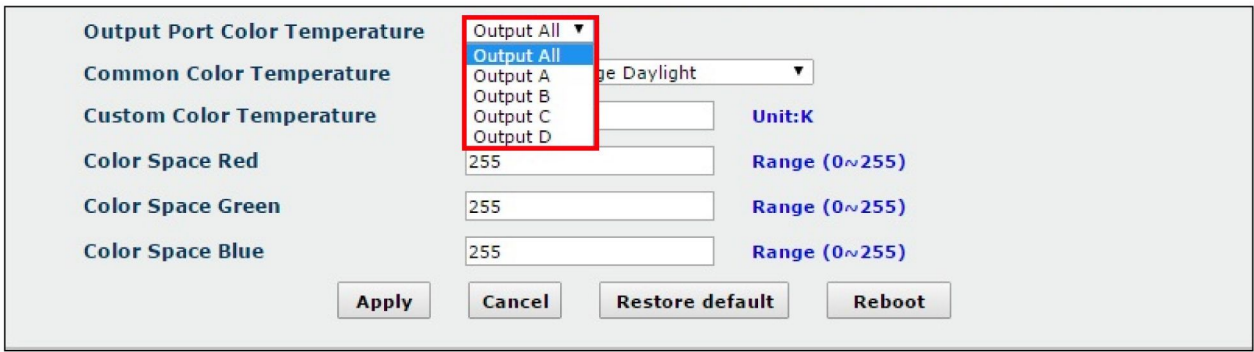

Figure 38: Output Port Color Temperature

- **Common Color Temperature**

Select from a list of the most common preset color temperature schemes. The default value is **Typical Average Daylight**.

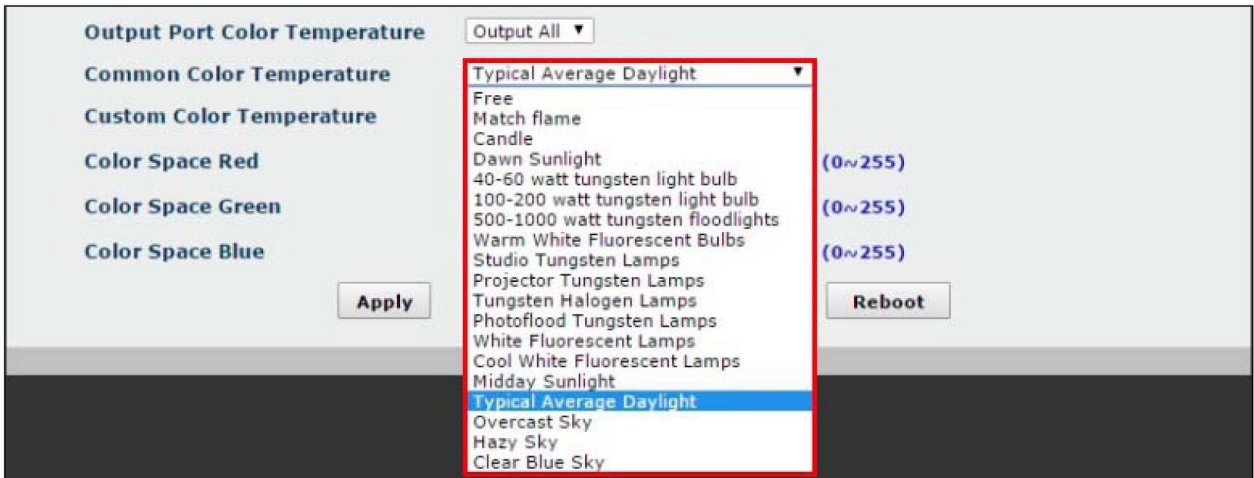

Figure 39: Common Color Temperature

- **Custom Color Temperature**

User configured custom setting. Color temperature is conventionally expressed in Kelvin, using the symbol K, a unit of measure for temperature based on the Kelvin scale. The higher color temperatures are called cool colors (bluish white), while lower color temperatures are called warm colors (yellowish white through red). The default value is **6500** Kelvin.

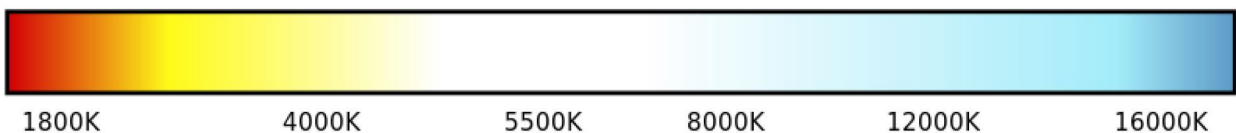

Figure 40: Color Temperature Bar

■ **Color Space Red / Green / Blue**

User configured custom setting. A color's RGB value indicates its red, green and blue intensity. Each intensity value is on a scale of 0 to 255. These default values are **255**.

RGB Value			Colour
Red	Green	Blue	
0	0	0	black
255	255	255	white
255	255	0	yellow
255	130	255	Pink
146	81	0	brown
157	95	82	purple
140	0	0	maroon

These are the 3 colors used to adjust the output image color that you see. For example:



Add Red Color Value



Add Green Color Value

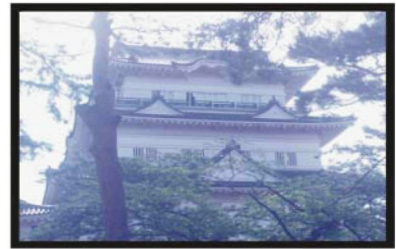

Add Blue Color Value

Figure 41: RGB Adjustment

☞ Click **“Restore Default”** button to restore all the changed values to factory default or click **“Apply”** button to accept the changed values and click **“Reboot”** button to make the changed values take effect properly.

7.2 Advance

For the **Advance** tab including **TFTP Server IP** and **File Name** configurations. The **Advance** Tab does not contain configuration settings, and should only be used by field service personnel.

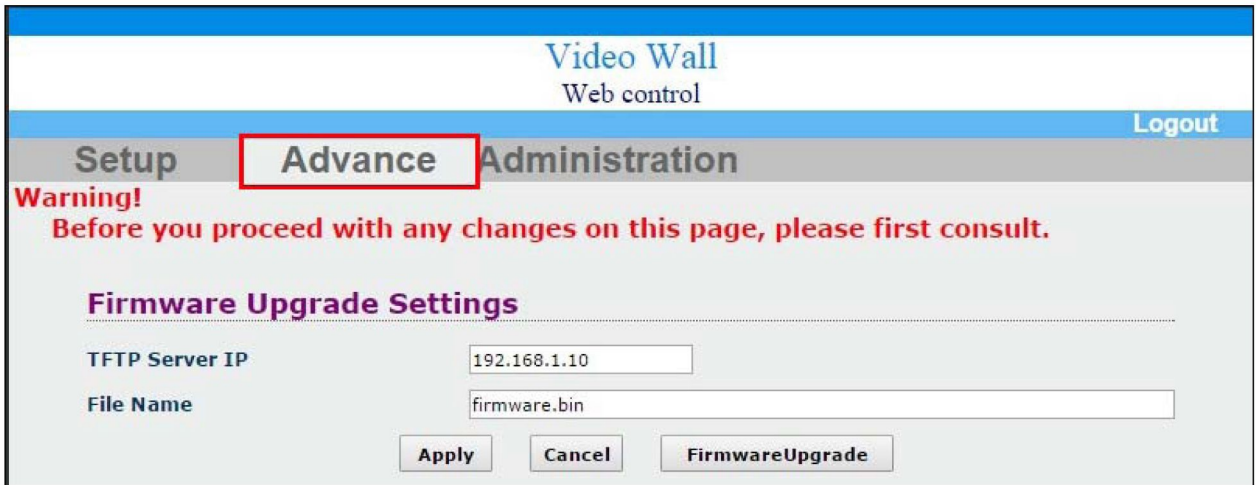

The screenshot displays the 'Video Wall Web control' interface. At the top, there is a blue header with the text 'Video Wall' and 'Web control'. Below this is a navigation bar with three tabs: 'Setup', 'Advance', and 'Administration'. The 'Advance' tab is highlighted with a red border. In the top right corner of the navigation bar, there is a 'Logout' link. Below the navigation bar, a red warning message reads: 'Warning! Before you proceed with any changes on this page, please first consult.' Underneath the warning, the section is titled 'Firmware Upgrade Settings'. This section contains two input fields: 'TFTP Server IP' with the value '192.168.1.10' and 'File Name' with the value 'firmware.bin'. At the bottom of this section, there are three buttons: 'Apply', 'Cancel', and 'FirmwareUpgrade'.

Figure 42: Web Control - Advance

⚠ Before you proceed with any changes on this page, please consult your agency firstly.

7.3 Administration

The screenshot shows the 'Administration' page of the 'Video Wall Web control' interface. The page has a blue header with the title 'Video Wall Web control' and a 'Logout' link in the top right corner. Below the header is a navigation bar with three tabs: 'Setup', 'Advance', and 'Administration', which is highlighted with a red box. The main content area is divided into three sections: 'Username', 'Password', and 'Network'. Each section has input fields and 'Apply' and 'Cancel' buttons.

Section	Field Name	Value
Username	Username	
	Buttons	Apply, Cancel
Password	Old Password	
	New Password	
	Confirm Password	
	Buttons	Apply, Cancel
Network	Static IP Address	192.168.1.151
	Static Subnet Mask	255.255.255.0
	Static Default Gateway	192.168.1.1
	Static DNS Server	168.95.1.1
	Buttons	Apply, Cancel

Figure 43: Web Control - Administration

7.3.1 Username

The default username for logging on to these setup webpage is **"admin"**. This can be changed to your preference. Click the corresponding **"Apply"** button after entering your information.

7.3.2 Password

The default password for logging on to these setup webpage is **"admin"**. This can be changed to your preference. Click the corresponding **"Apply"** button after entering your information.

7.3.3 Network

- **Static IP Address**

The IP Address of the device. This should be set to an address on the same subnet as the computer (or network) it will be controlled from.

- **Static Subnet Mask**

Default subnet masks depend on the class of your network.

Network class	Network IP addresses	Subnet Mask
Class A	10.xxx.xxx.xxx	255.255.0.0
Class B	172.xxx.xxx.xxx	255.255.240.0
Class C	192.168.xxx.xxx	255.255.255.0

- **Static Default Gateway**

Set as applicable for your network. Contact your I.T. department.

- **Static DNS Server**

Set as applicable for your network. Contact your I.T. department.

CHAPTER 8 TROUBLESHOOTING

1. What to do if LED is fail in display?

Answer: Check the connection of power cord is not loosening and the power cord is in a good status having no any damage. Check the power source is normally.

2. What to do if you sense the power leakage during plugging or unplugging of the input/output ports?

Answer: It could be that the equipment power is not properly grounded. You must properly ground your equipment; otherwise product life can easily be shortened.

3. What to do if operation and function failure occurred?

Answer: Check if the equipment and the splitter or D.A system are in proper connection. If the problem persists, send the product to the maintenance center for repair.

4. How to avoid the equipment failure due to the high temperature?

Answer: Place the equipment in a ventilate location. If it is still not to be improved, please check with the build-in fan whether is damaged. Or contact your agency for helping.

5. What to do if IR function failure occurred?

Answer: Check the battery of remote controller is NOT running low and the IR connector is not loosening. Check whether the remote controller is aiming at the IR receiver accurately.

2x2 Mode

Connection 1:

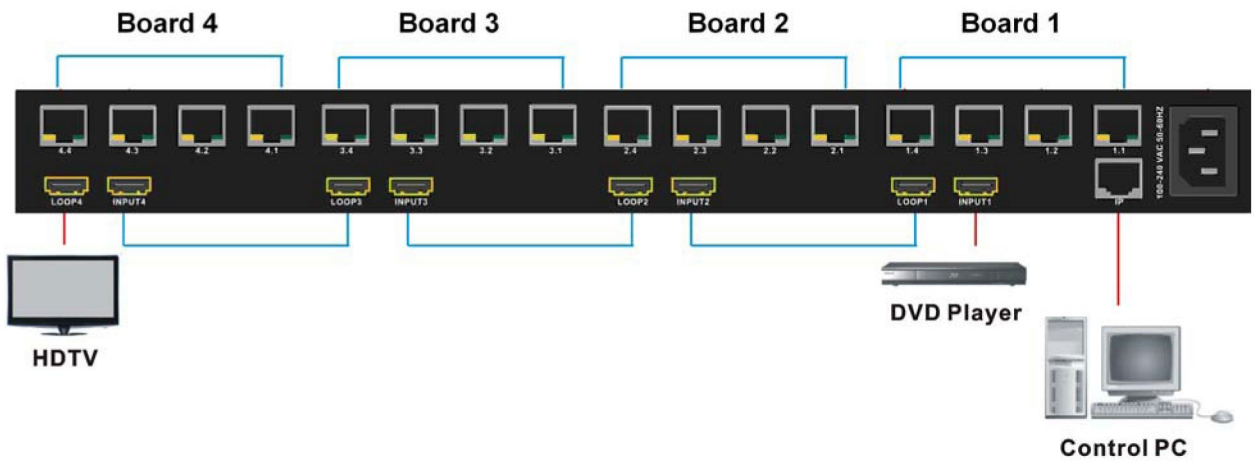

Original Import Image

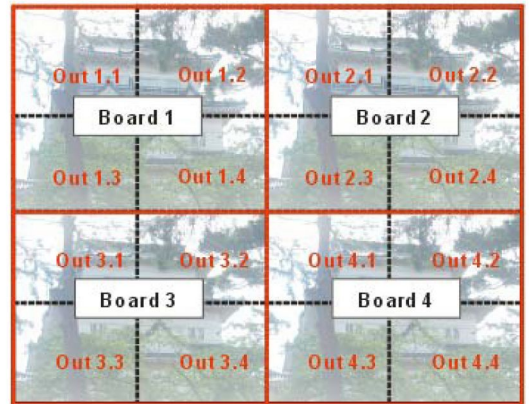
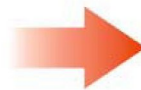

Output Image through the output ports

Figure 47: 2x2 Mode Status 1

Connection 2:

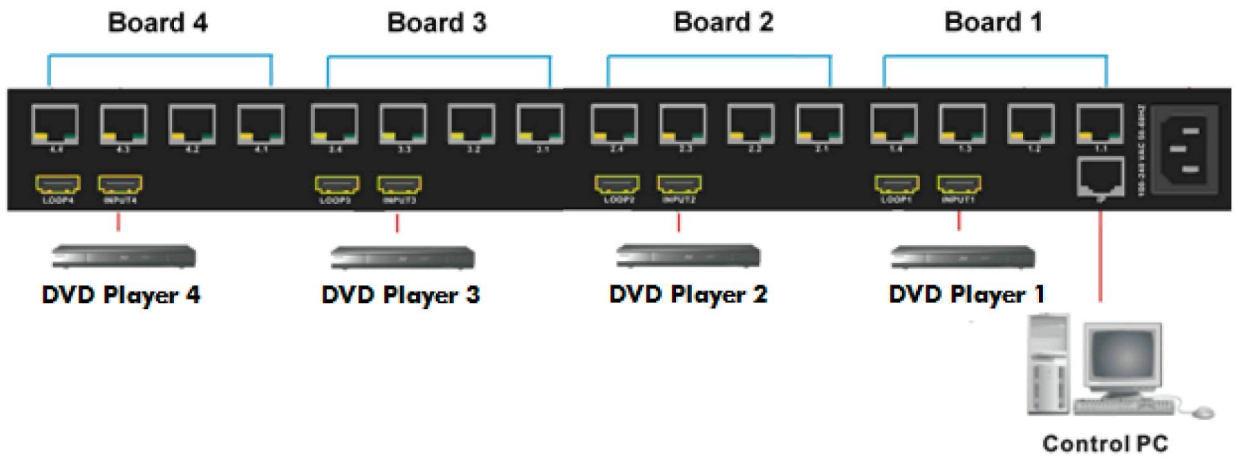

Original Import Image

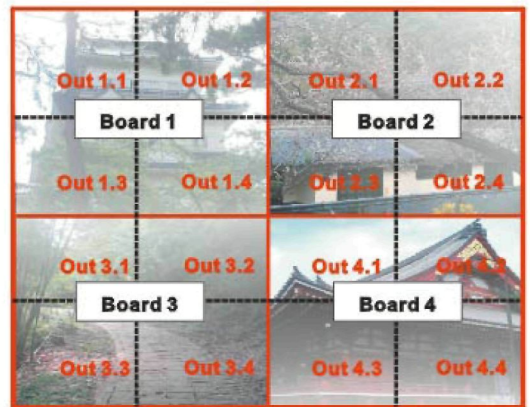
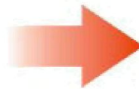

Output Image through the output ports

Figure 48: 2x2 Mode Status 2

Connection 3:

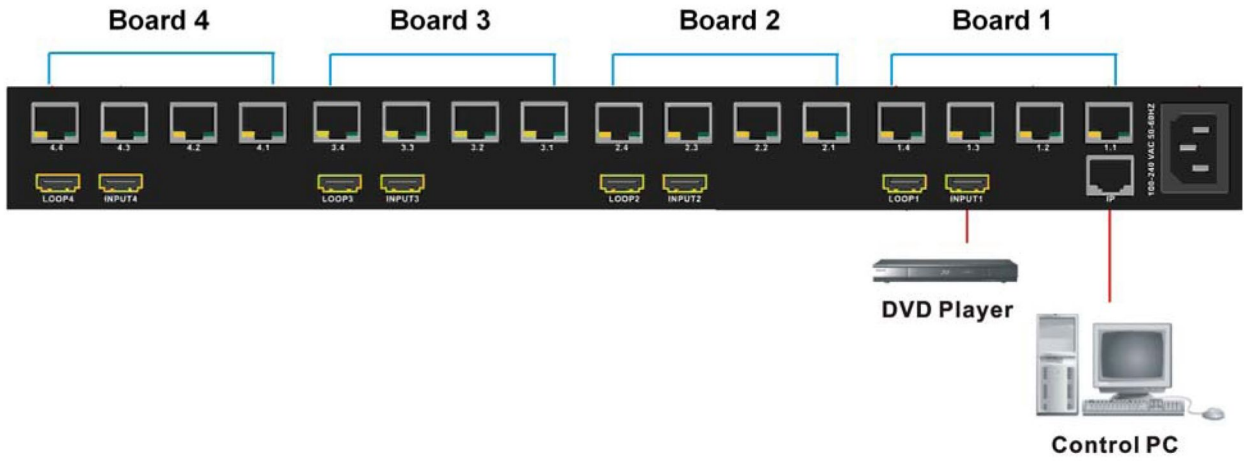

Original Import Image

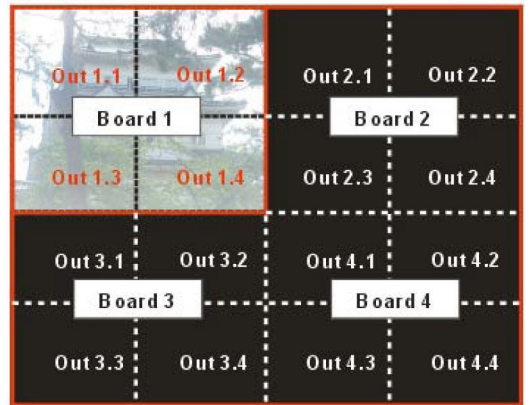
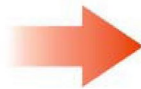

Output Image through the output ports

Figure 49: 2x2 Mode Status 3

3x3 Mode



Original Import Image

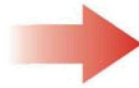

Output Image through the output ports

Figure 50: 3x3 Mode

☞ Output ports: Out 4.1~Out 4.4, Out 1.4, Out 2.4, Out 3.4 and Out 4.4 are not used.

4x4 Mode



Original Import Image

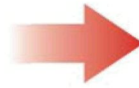

Output Image through the output ports

Figure 51: 4x4 Mode

1x3 CW Mode



Original Import Image

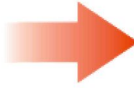

Out 1.1	Out 2.1	Out 3.1	Out 4.1
Out 1.2	Out 2.2	Out 3.2	Out 4.2
Out 1.3	Out 2.3	Out 3.3	Out 4.3
Out 1.4	Out 2.4	Out 3.4	Out 4.4

Output Image through the output ports

Figure 52: 1x3 CW Mode

☞ Output ports: Out 1.4, Out 2.4, Out 3.4 and Out 4.4 are not used.

1x3 CCW Mode



Original Import Image

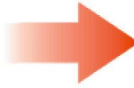

Out 1.1	Out 2.1	Out 3.1	Out 4.1
Out 1.2	Out 2.2	Out 3.2	Out 4.2
Out 1.3	Out 2.3	Out 3.3	Out 4.3
Out 1.4	Out 2.4	Out 3.4	Out 4.4

Output Image through the output ports

Figure 53: 1x3 CCW Mode

☞ Output ports: Out 1.4, Out 2.4, Out 3.4 and Out 4.4 are not used.

Landscape 1x3 A/B/C Mode

Landscape 1x3 A



Original Import Image

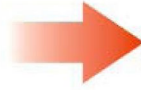

Out 1.1	Out 2.1	Out 3.1	Out 4.1
Out 1.2	Out 2.2	Out 3.2	Out 4.2
Out 1.3	Out 2.3	Out 3.3	Out 4.3
Out 1.4	Out 2.4	Out 3.4	Out 4.4

Output Image through the output ports

Figure 54: Landscape 1x3 A Mode

Landscape 1x3 B



Original Import Image



Out 1.1	Out 2.1	Out 3.1	Out 4.1
Out 1.2	Out 2.2	Out 3.2	Out 4.2
Out 1.3	Out 2.3	Out 3.3	Out 4.3
Out 1.4	Out 2.4	Out 3.4	Out 4.4

Output Image through the output ports

Figure 55: Landscape 1x3 B Mode

Landscape 1x3 C



Original Import Image

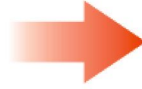

Out 1.1	Out 2.1	Out 3.1	Out 4.1
Out 1.2	Out 2.2	Out 3.2	Out 4.2
Out 1.3	Out 2.3	Out 3.3	Out 4.3
Out 1.4	Out 2.4	Out 3.4	Out 4.4

Output Image through the output ports

Figure 56: Landscape 1x3 C Mode

☞ Output ports: Out 1.4, Out 2.4, Out 3.4 and Out 4.4 are not used. Partition 1 to 4 output ports will transmit the signals independently.

3x4 Mode A / 3x4 Mode B

3x4 Mode A



Original Import Image

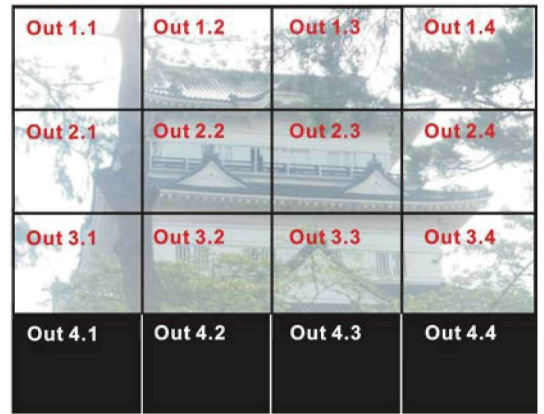
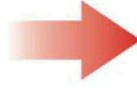

Output Image through the output ports

Figure 57: 3x4 Mode A

3x4 Mode B



Original Import Image

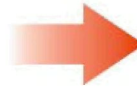

Output Image through the output ports

Figure 58: 3x4 Mode B

2x3 Mode A / 2x3 Mode B

2x3 Mode A



Original Import Image

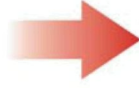

Output Image through the output ports

Figure 59: 2x3 Mode A

2x3 Mode B



Original Import Image

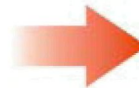

Output Image through the output ports

Figure 60: 2x3 Mode B

2x8 CW / 2x8 CCW

2x8 CW



Original Import Image

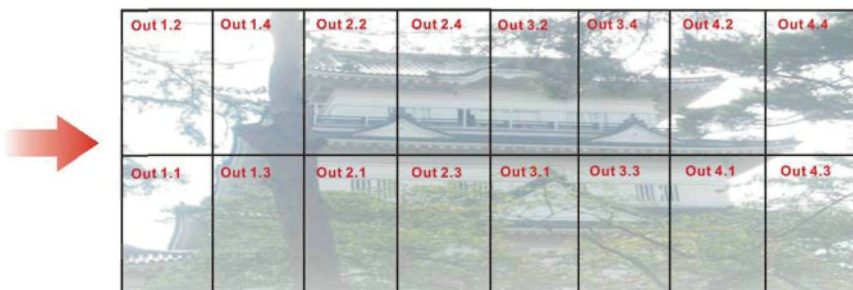

Output Image through the output ports

Figure 61: 2X8 CW Mode

2x8 CCW



Original Import Image



Output Image through the output ports

Figure 62: 2X8 CCW Mode