

# KPC *Series*

## User Manual



# Safety

## IMPORTANT SAFETY INSTRUCTIONS

1. To disconnect the machine from the electrical power supply, turn off the power switch and remove the power cord plug from the wall socket. The wall socket must be easily accessible and in close proximity to the machine.
2. Read these instructions carefully. Save these instructions for future reference.
3. Follow all warnings and instructions marked on the product.
4. Do not use this product near water.
5. Do not place this product on an unstable cart, stand, or table. The product may fall, causing serious damage to the product.
6. Slots and openings in the cabinet and the back or bottom are provided for ventilation; to ensure reliable operation of the product and to protect it from overheating. These openings must not be blocked or covered. The openings should never be blocked by placing the product on a bed, sofa, rug, or other similar surface. This product should never be placed near or over a radiator or heat register, or in a built-in installation unless proper ventilation is provided.
7. This product should be operated from the type of power indicated on the marking label. If you are not sure of the type of power available, consult your dealer or local power company.
8. Do not allow anything to rest on the power cord. Do not locate this product where persons will walk on the cord.
9. Never push objects of any kind into this product through cabinet slots as they may touch dangerous voltage points or short out parts that could result in a fire or electric shock. Never spill liquid of any kind on the product.

## CE MARK



This device complies with the requirements of the EEC directive 2004/08/EC with regard to "Electromagnetic compatibility" and 2006/95/EC "Low Voltage Directive".

## FCC

This device complies with part 15 of the FCC rules. Operation is subject to the following two conditions:

- (1) This device may not cause harmful interference.
- (2) This device must accept any interference received, including interference that may cause undesired operation.

## CAUTION ON LITHIUM BATTERIES

There is a danger of explosion if the battery is replaced incorrectly. Replace only with the same or equivalent type recommended by the manufacturer. Discard used batteries according to the manufacturer's instructions.

## LEGISLATION AND WEEE SYMBOL

**2002/96/EC Waste Electrical and Electronic Equipment Directive on the treatment, collection, recycling and disposal of electric and electronic devices and their components.**



The crossed dustbin symbol on the device means that it should not be disposed of with other household wastes at the end of its working life. Instead, the device should be taken to the waste collection centers for activation of the treatment, collection, recycling and disposal procedure.

To prevent possible harm to the environment or human health from uncontrolled waste disposal, please separate this from other types of wastes and recycle it responsibly to promote the sustainable reuse of material resources.

Household users should contact either the retailer where they purchased this product, or their local government office, for details of where and how they can take this item for environmentally safe recycling.

Business users should contact their supplier and check the terms and conditions of the purchase contract.

This product should not be mixed with other commercial wastes for disposal.

# Table of Contents

<b>1. Item Checklist</b> .....	<b>5</b>
<b>2. System View</b> .....	<b>6</b>
2.1. Front View .....	6
2.1. Rear View.....	6
2.2. I/O View	7
<b>3. Drivers Installation</b> .....	<b>8</b>
3.1. Driver List .....	8
3.2. Chipset Driver Installation.....	8
3.2. USB 2.0 Driver Installation .....	10
3.3. VGA Driver Installation .....	13
3.4. ELO Touch Driver Installation .....	15
3.5. POSTouch Driver Installation .....	18
3.6. 10/100Mb LAN Driver Installation.....	20
<b>4. System Disassembly</b> .....	<b>21</b>
4.1. Replacing the Slimline HDD .....	21
4.2. Opening the Rear Cover .....	22
4.3. Replace Heatsink /Fan & CPU .....	23
4.4. Replacing the Touch Board .....	24
4.5. Replacing the Inverter Board.....	24
4.6. Replacing the Speakers .....	25
4.7. Replacing the Motherboard .....	25
<b>5. Specification</b> .....	<b>27</b>
<b>6. Jumper Settings</b> .....	<b>29</b>
<b>7. BIOS Settings</b> .....	<b>36</b>
<b>8. Airflow Requirements</b> .....	<b>39</b>

# 1. Item Checklist

Take the system unit out of the carton. Remove the unit from the carton by holding it by the foam inserts:



a. Driver CD



b. Com port Cable



c. Power Cable



d. Power Adapter



e. System

## 2. System View

### 2.1. Front View

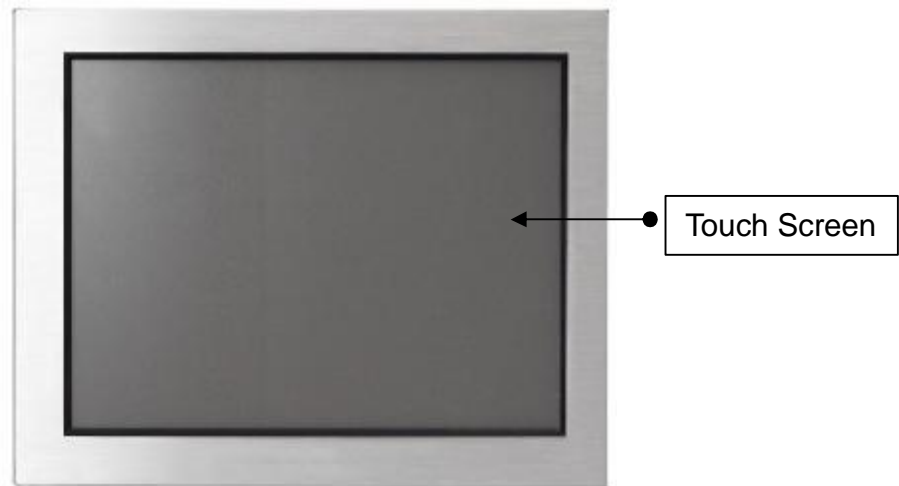

### 2.1. Rear View

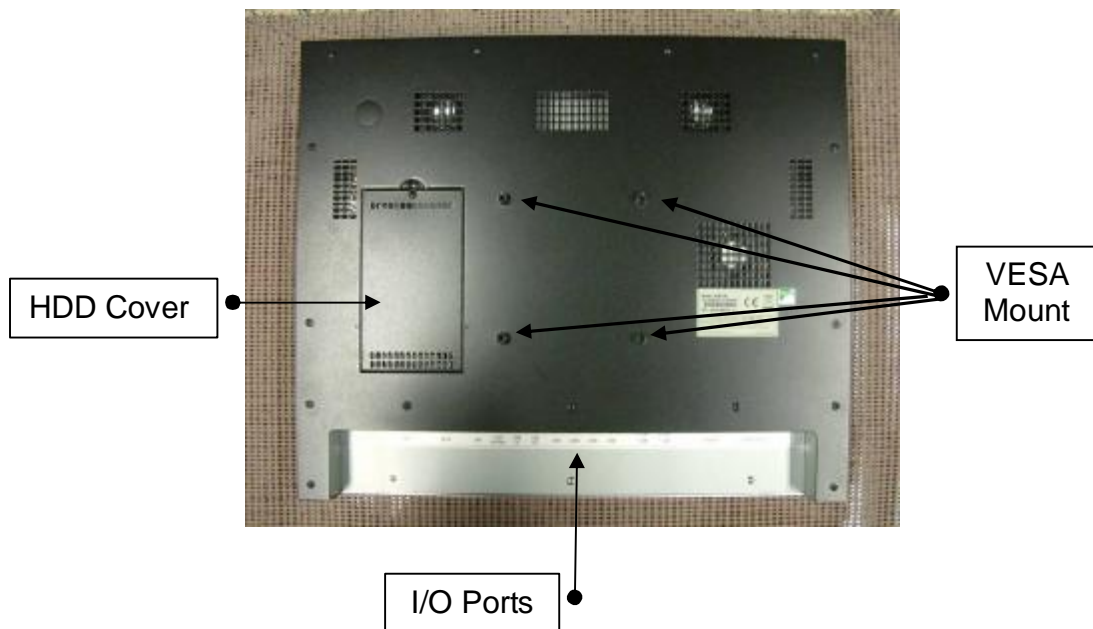

## 2.2. I/O View

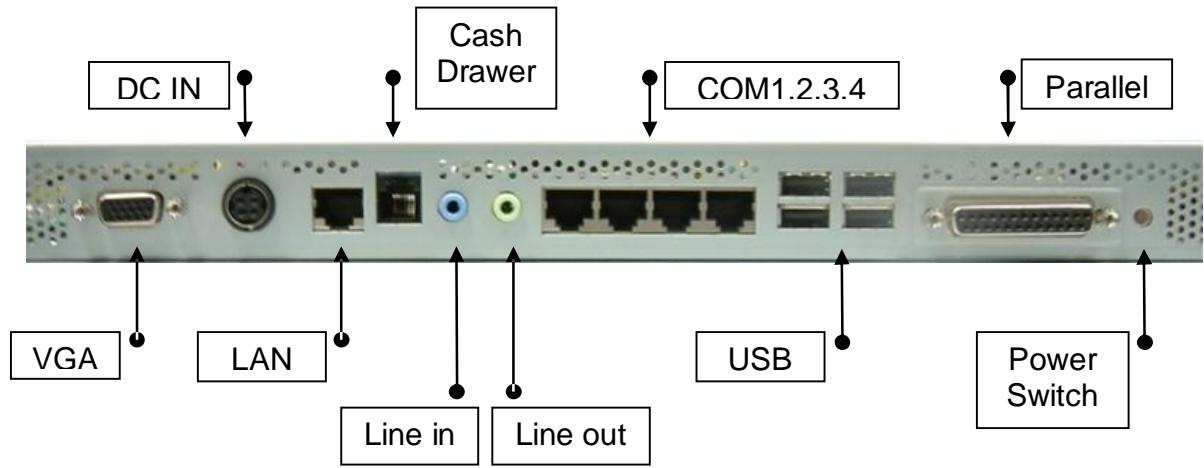

## 3. Drivers Installation

### 3.1. Driver List

Folder/File	File Description
<CD>:\K790_B78\B78.htm	B78 Driver List
<CD>:\COMMON\INTEL\Chipset	Chipset Driver
<CD>:\COMMON\INTEL\USB 20	USB 2.0 Driver
<CD>:\COMMON\INTEL\VGA\i85x	VGA Driver
<CD>:\COMMON\Elo_Touch\Win2K_XP\SAW\V4.30	ELO Touch Driver
<CD>:\COMMON\POS_Touch	POSTouch Driver
<CD>:\COMMON\Lan_driver\R8139_810x	10/100Mb LAN Driver

-The following procedures are for Windows 2000/XP, other platforms are similar.

### 3.2. Chipset Driver Installation

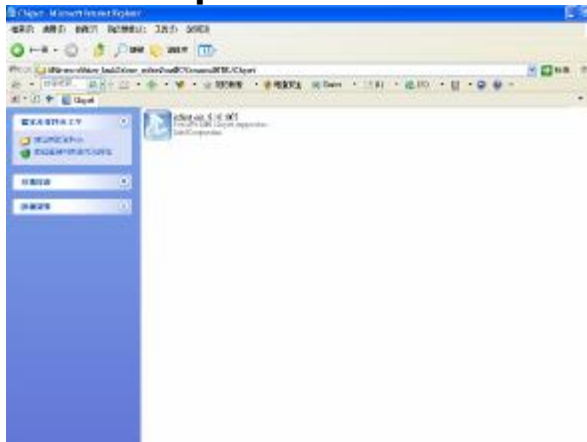

a. Double click “infinst\_enu\_6.0.1.1007” on the My computer window.



b. Click the “Next” button on the Welcome window.

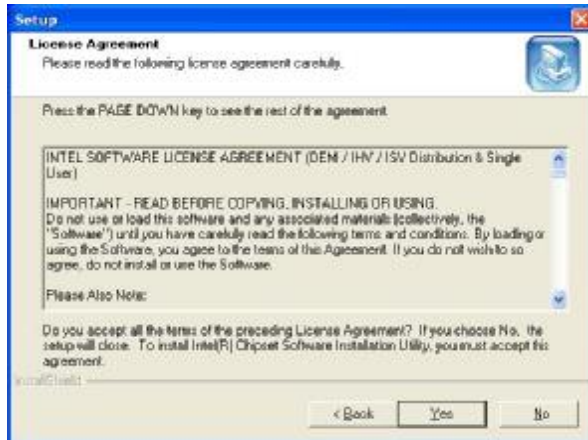

c. Click the “Yes” button on the License Agreement window.

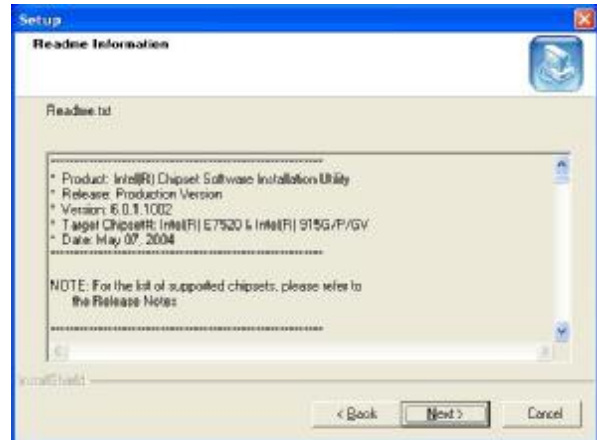

d. Click the “Next” button on the Readme Information window.

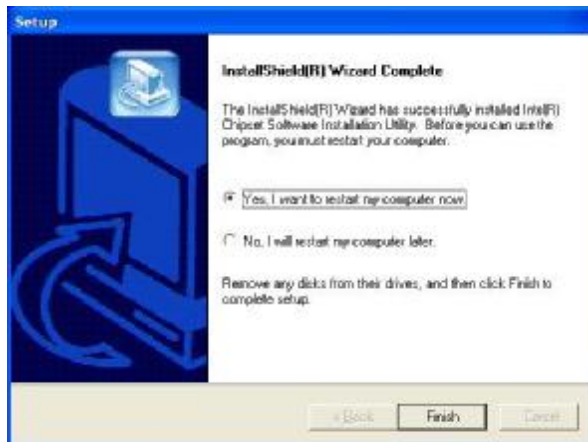

e. Click the “Finish” button and restart your system.

## 3.2. USB 2.0 Driver Installation

### OS Requirements

OS	USB 2.0 requirements
Windows XP	USB 2.0 drivers are provided in <a href="#">Service Pack 1</a> (SP1) for Windows XP, which is available through <a href="#">Windows Update</a> .
Windows 2000	USB 2.0 drivers are available through <a href="#">Windows Update</a> or Service Pack 4.
Windows 98SE/Me	USB 2.0 drivers are available on the <a href="#">Intel developer site</a> .
Windows 98 (Retail)	Developers and OEMs should contact <a href="#">Orange Ware</a> . For end-users, if your device does not ship with Windows 98 drivers, contact your device or system manufacturer. If USB 2.0 drivers are not available, your device will operate at USB 1.1 speeds
Linux	USB 2.0 support is available in <a href="#">kernel 2.4.19</a> or later development kernels, or in the 2.4.19 or later production kernel. <a href="#">More information</a> .

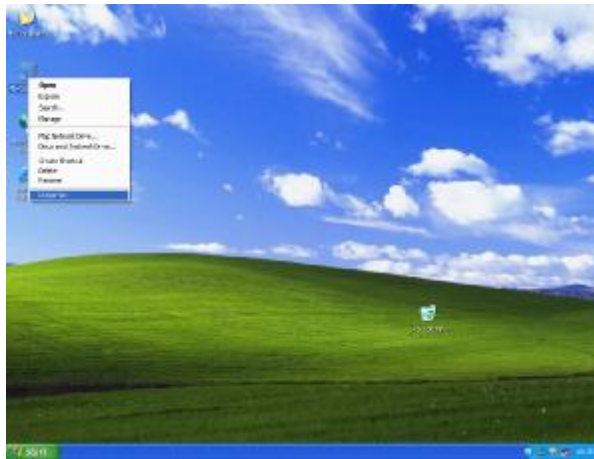

- a. Right click My Computer on the desktop and select “properties”

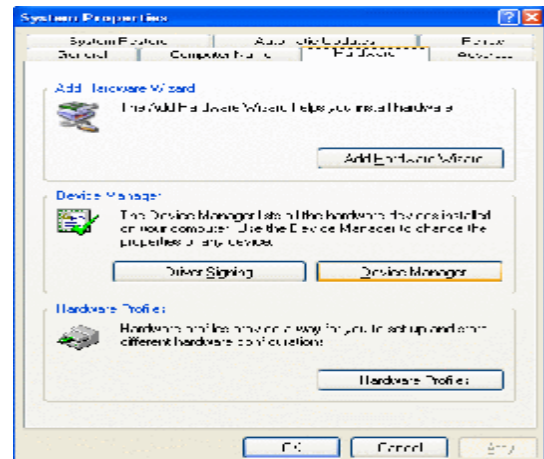

- b. Select “Hardware” → “Device Manager” on system properties.

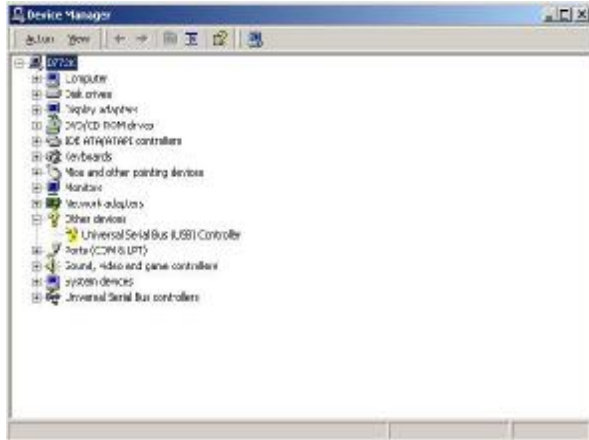

c. Select "Other Devices" à "Universal Serial Bus (USB) Controller" à "Properties" on Device Manager.

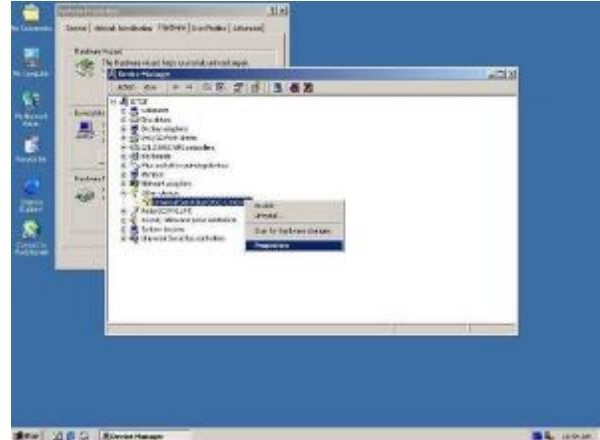

d. Select "Device" à "Update Driver...".



e. Click the "Next" button on the welcome window.



f. Select "Search for a suitable..." and click the "Next" button on the Install Hardware Device Drivers window.



g. Select "Specify a location" and click the "Next" button on the Locate Driver Files window.



h. Press “Browse” to select the driver and then click the “OK” button to go to the next page.



i. Click the “Next” button on the Driver Files Search Results window.



j. Click the “Finish” button to complete this process.

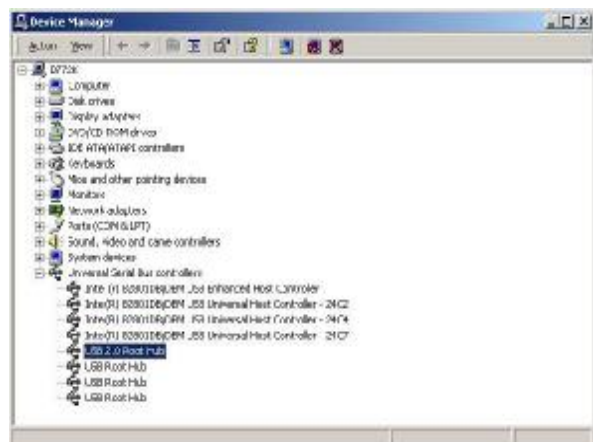

k. Finished.

### 3.3. VGA Driver Installation

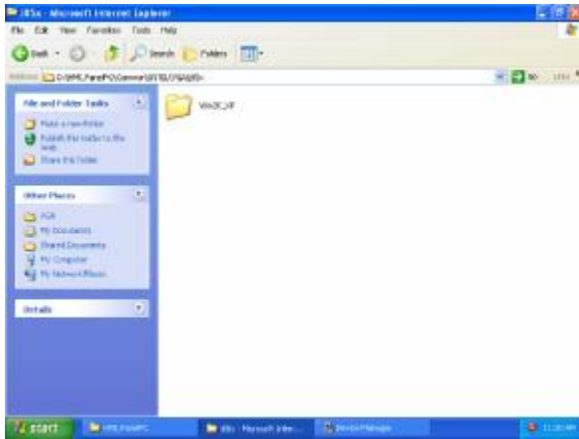

a. Click the “Win2K\_XP” on the My Computer window.

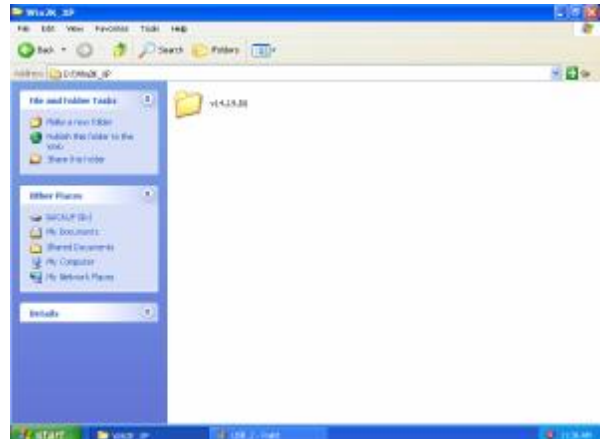

b. Click the “v14.19.50” on the My Computer window.

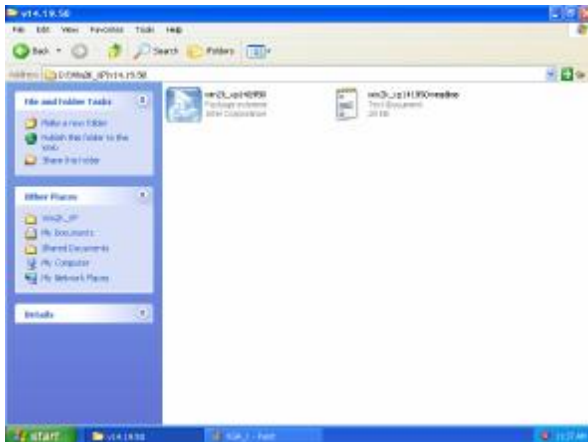

c. Select “win2k\_xp141950” on the v14.19.50 window.

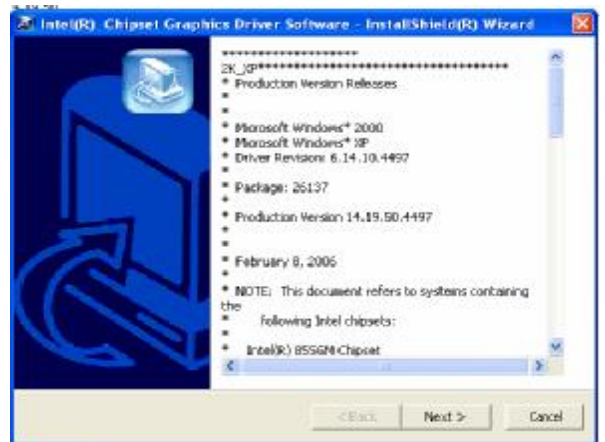

d. Click the “Next” button on the Intel(R) Chipset Graphics Driver Software-InstallShield(R) Wizard window.

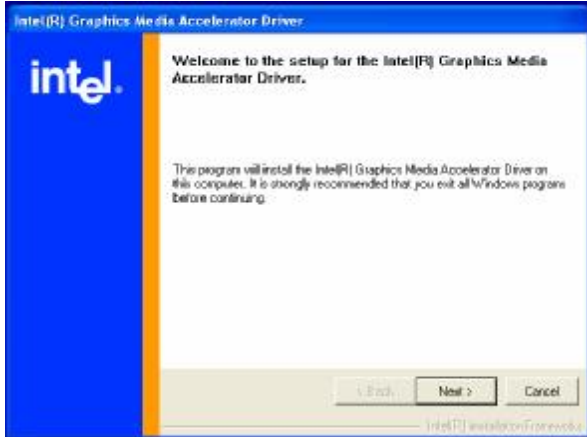

- e. Click the “Next” button on the Intel(R) Graphics Media Accelerator Driver window.



- f. Click the “Yes” button on the Intel(R) Graphics Media Accelerator Driver window.

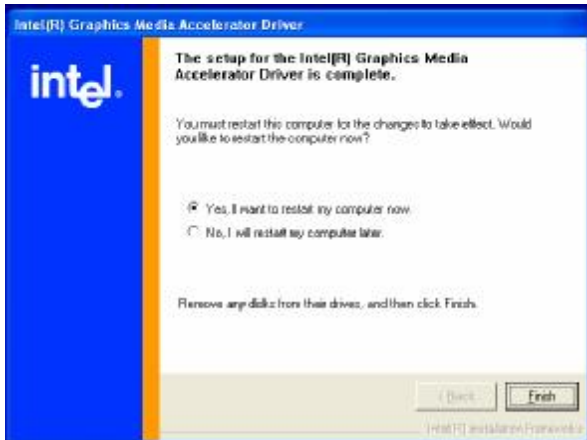

- g. Select “Yes, I want to restart my computer now” and click the “Finish” button on the Intel(R) Graphics Media Accelerator Driver window.

### 3.4. ELO Touch Driver Installation

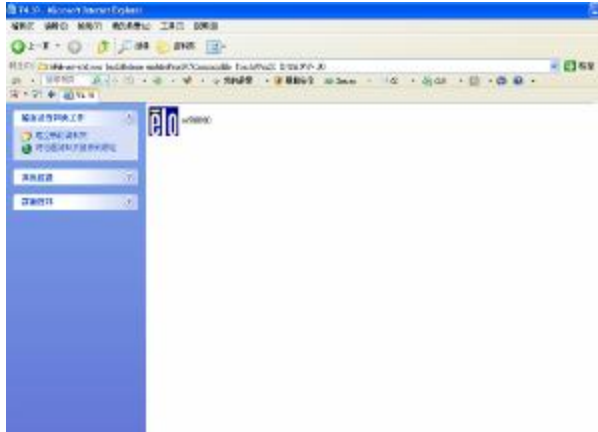

a. Click "sw500930" on the My computer window.



b. Click the "OK" button on the Welcome window.



c. Click the "Unzip" button on the WinZip Self-Extractor window.



d. Select "Install Serial Touchscreen Drivers" and then click the "Next" button on the Welcome window.

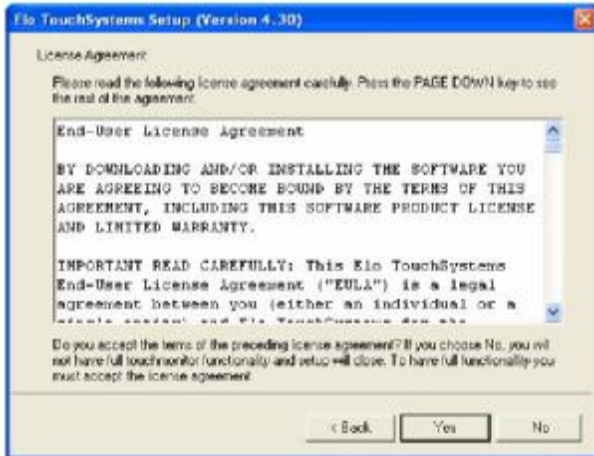

e. Click the “Yes” button on the License Agreement window.



f. Click the “Next” button on the on the “Select the COM ports...” window.

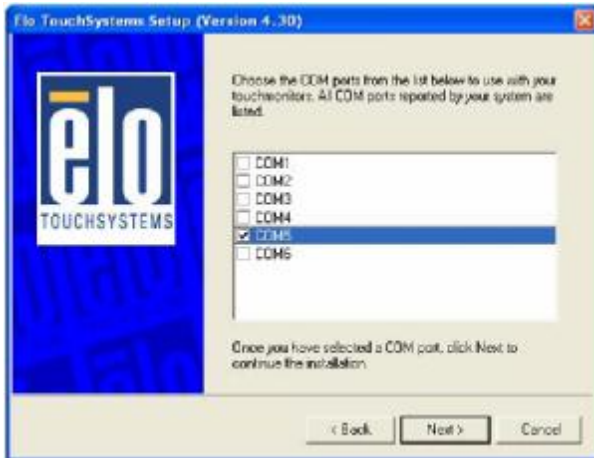

g. Select “COM5” and click the “Next” button on the Choose the COM ports... window.



h. Click the “Next” button on the You have selected the COM ports... window.



i. Click the “Finish” button on the Setup Complete window



j. Click the “Yes” button and restart your system.



k. After the computer has restarted, click “Align” on the Elo Touchscreen Properties window.



l. Follow the instructions on the screen to calibrate the touch panel.

### 3.5. POSTouch Driver Installation

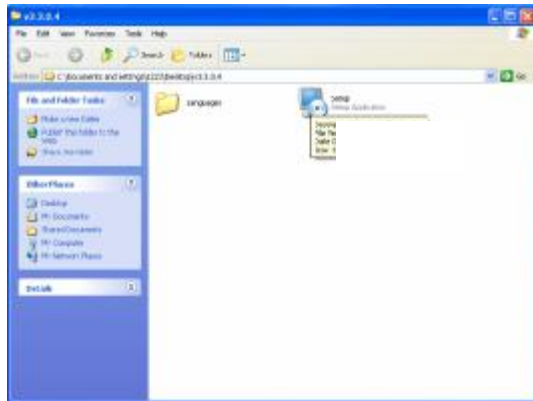

a. Double click the "Setup" on the "My Computer" window.



b. Click the "Next" button on the "Welcome window".

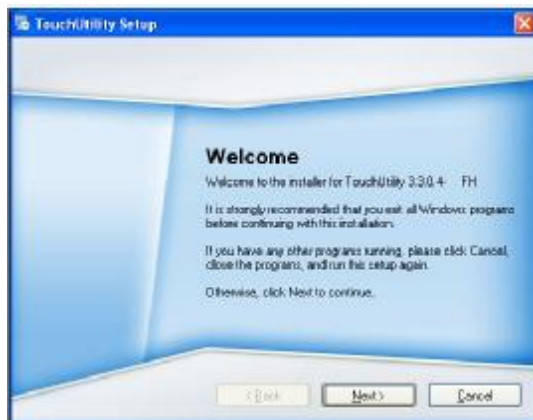

c. Click the "next" button on the "Wellcome" window.

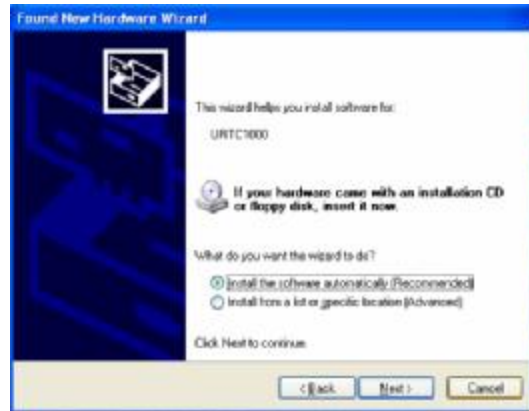

d. Select "Install the software automatically" and click the "Next" button on the "URTC1000" window



e. Click the "Next" button on the "License Agreement" window.



f. Click the "Next" button on the "Install Folder" window.

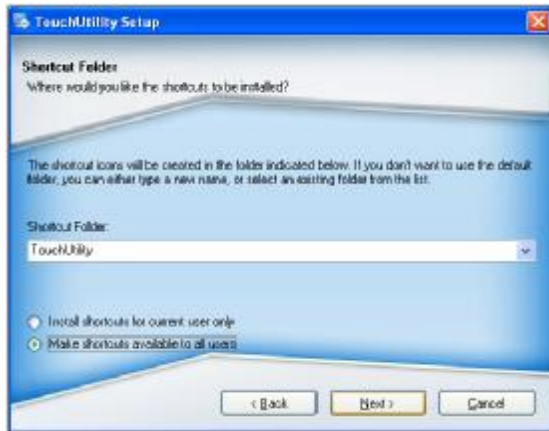

g. Click the “Next “ button on the “Shortcut Folder” window.



h. Select the “USB” and click the ”Next” button on the “Options” window.

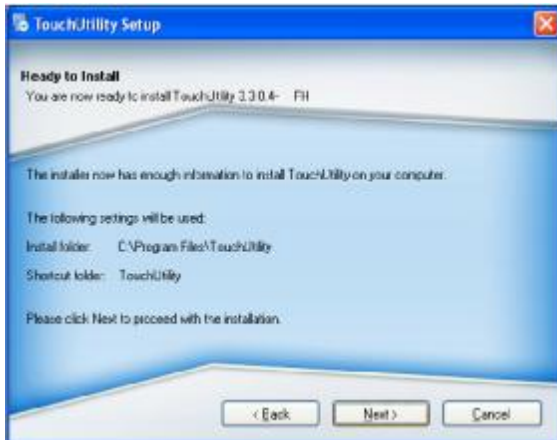

i. Click the “Next” button on the “Ready to Install” window



j. Click the “Continue Anyway” button on the URTC-1000 window

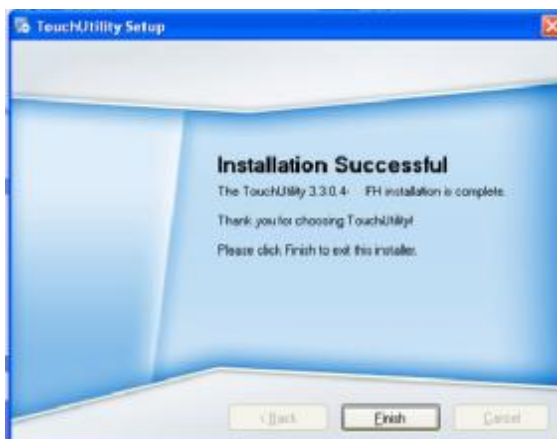

k. Click the “Finish” button on the “Installation Successful” window .

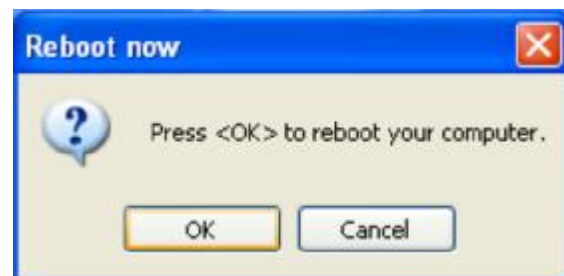

l. Click the “OK” button to reboot your computer

### 3.6. 10/100Mb LAN Driver Installation

• BLC Touch	Vista	• USB v1.0: No support multi monitor function.
	Vista	• RS232: No driver support now
Resistive Touch Screen	Linux	
	Linux	
• POS Touch	Win9X, ME, 2K, XP	
	Vista	
	Linux	
	Linux	
10/100Mb LAN	Win9X, ME, 2K, XP	
• Realtek RTL8139/810x	Win9X, ME, 2K, XP	
	Win9X, ME, 2K, XP	
	Linux	
	WinCE 3.0	
WiFi PCI IEEE802.11a/b/g	Win9X, ME	
Wireless LAN	Win9X, XP	
• 3.5GHz CW10	Vista	
	Linux	
WiFi PCI IEEE802.11a/b/g	Win9X, XP	
Wireless LAN	Win9X, XP	
	Win9X, XP	
• Intel PRO/1000	Vista	
• Intel PRO/1000	Vista	
• Intel PRO/1000	Vista	
• Intel PRO/1000	Vista	

a. Click "Win9X,ME. 2K.XP"

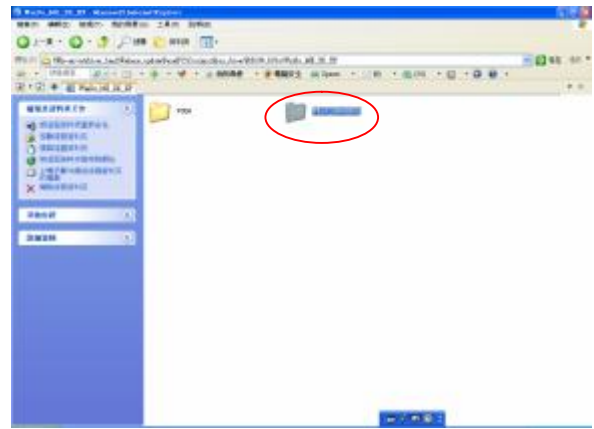

b. Double click "V616(20040809)" on the My Computer window.



c. Double click "Setup" on the My Computer window.

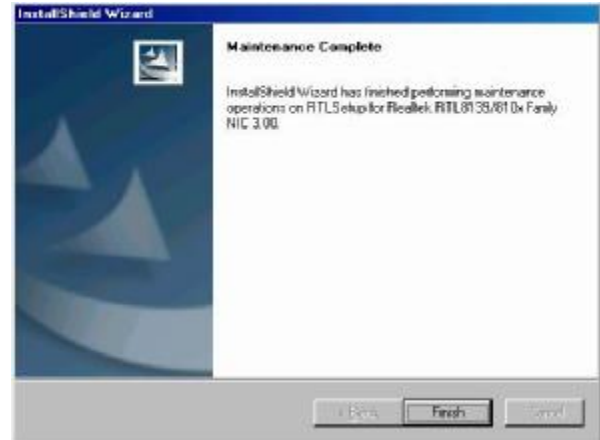

d. Click the "Finish" button on the Maintenance Complete window.

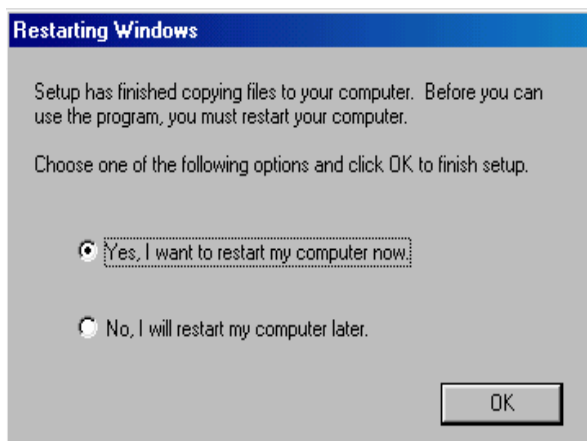

e. Click the "OK" button and restart your system.

## 4. System Disassembly

### 4.1. Replacing the Slimline HDD

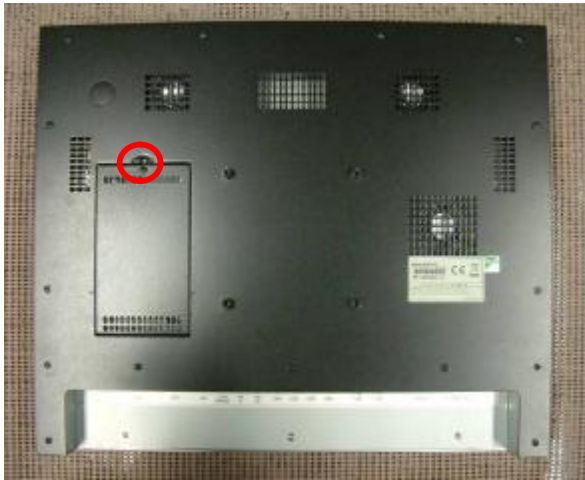

a. Remove the screw (1).



b. Remove the HDD cover.



c. Pull the HDD front.



d. Disconnect the cable (1) to replace the HDD.

## 4.2. Opening the Rear Cover

To replace the heatsink / fan and CPU, please first follow the steps in chapter 4.1.

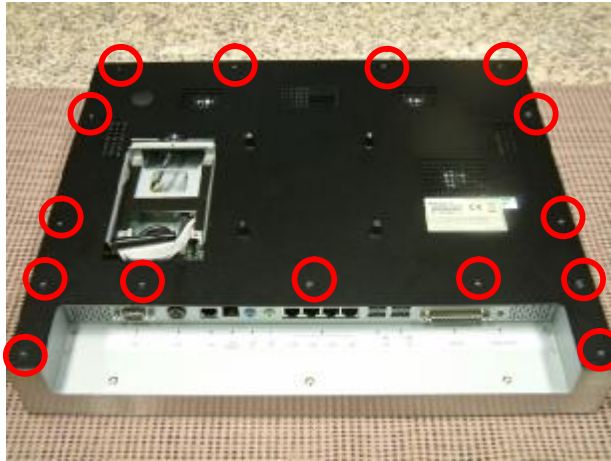

a. Remove the screws (11)



b. Remove the rear cover

### 4.3. Replace Heatsink /Fan & CPU

To replace the heatsink/fan and CPU, please first follow the steps in chapter 4.1 and 4.2.

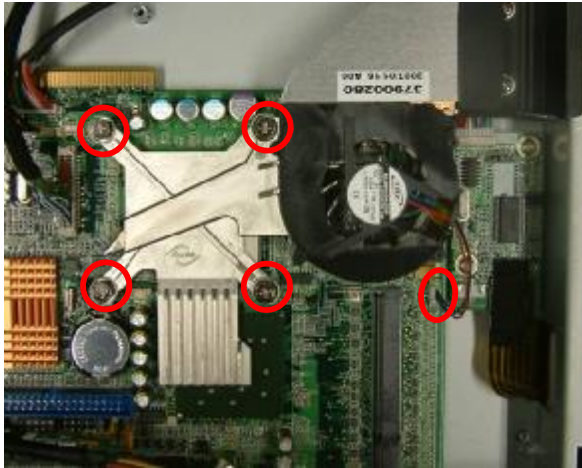

a. Disconnect the fan cable (1) and loosen the screws (4) to remove the heatsink / fan

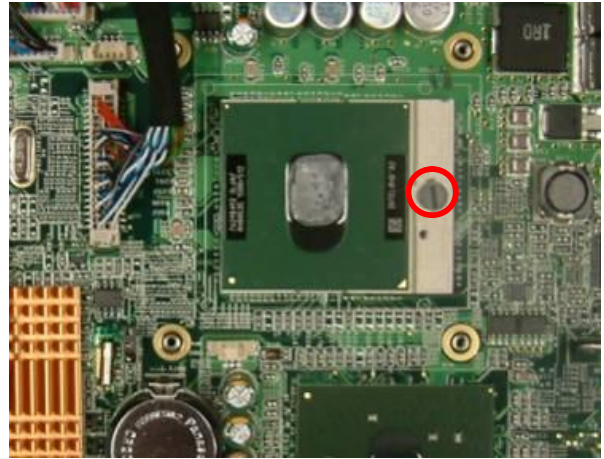

b. Turn the socket lock screw 180 degrees to unlock it and remove the CPU.



c. Remove the screws (2) to remove the fan tunnel.

## 4.4. Replacing the Touch Board

To replace the touch board, please first follow the steps in chapter 4.1 and 4.2

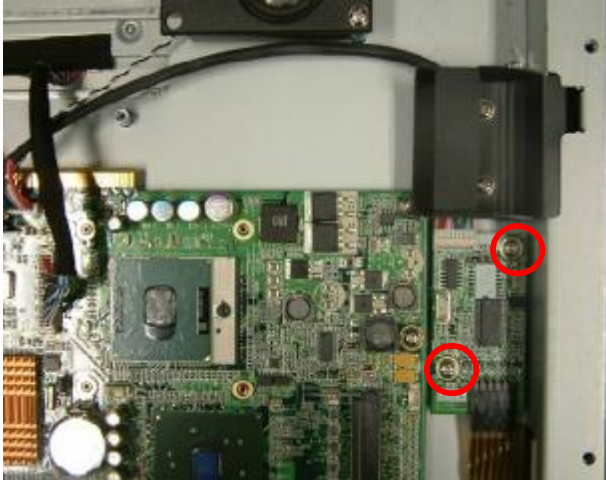

a. Remove the screws (2) .

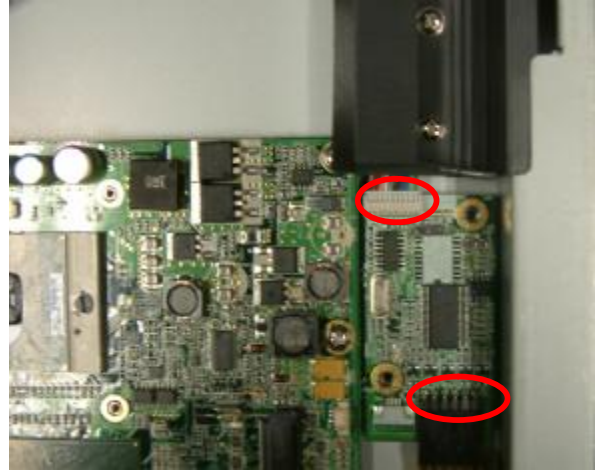

b. Remove the screws (2) to replace the touch board.

## 4.5. Replacing the Inverter Board

To replace the inverter board, please first follow the steps in chapter 4.2

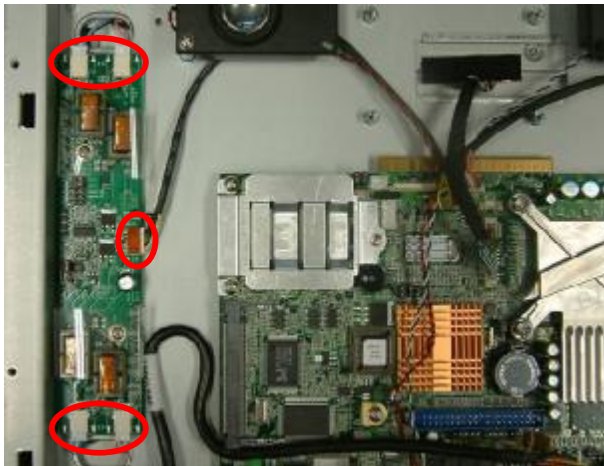

c. Disconnect the cables (5) .

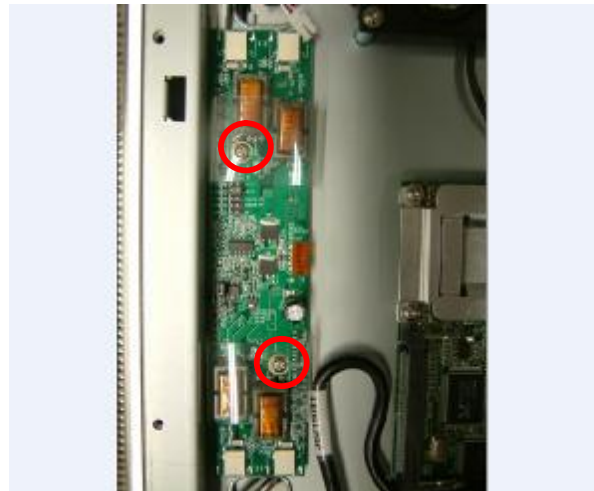

d. Remove the screws (2) to remove the inverter board.

## 4.6. Replacing the Speakers

To replace the speaker, please first follow the steps in chapter 4.1 and 4.2

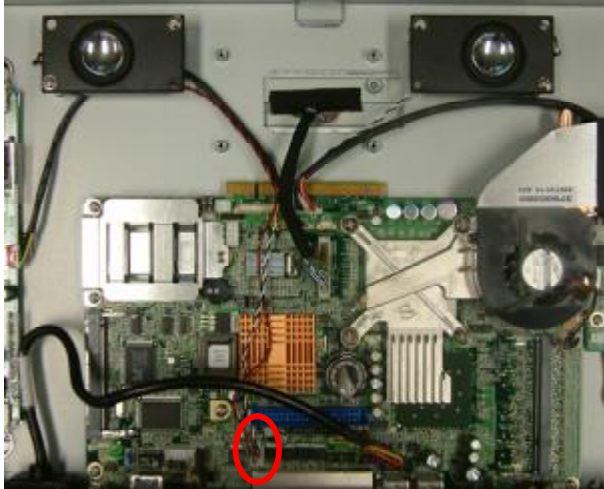

a. Disconnect the cable (1)

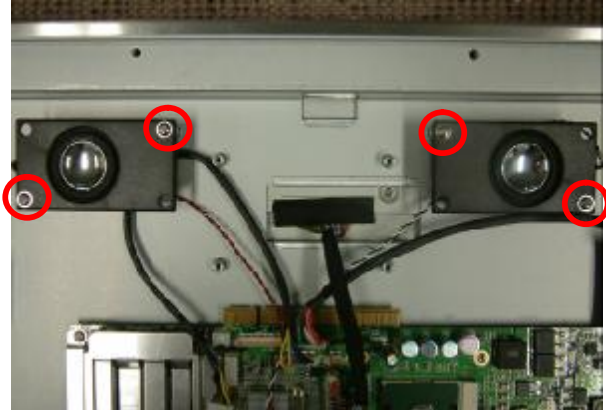

b. Remove the screws (4) to replace the speakers.

## 4.7. Replacing the Motherboard

To replace the motherboard, please first follow the steps in chapter 4.1, 4.2, 4.3(a)

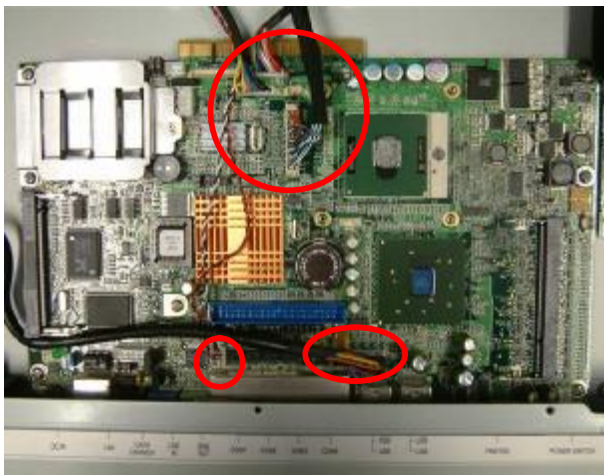

a. Disconnect the cables (5): touch cable, inverter cable, LCD interface cable, VGA cable, and speaker cable.



b. Remove the hex screws (2).

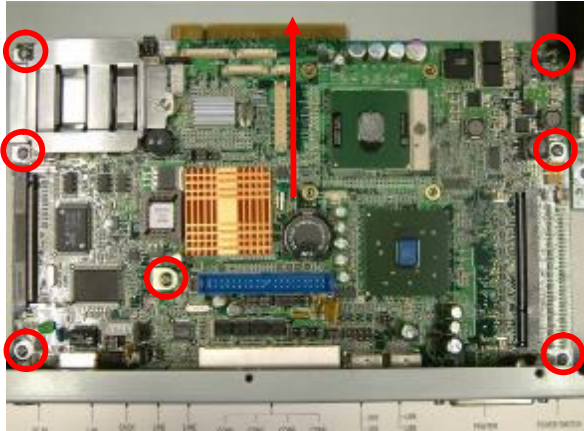

- c. Remove the screws (7) and slide the motherboard in the direction as shown by the arrow to remove it.

## 5. Specification

<b>Main Name</b>	<b>KPC1200</b>	<b>KPC1500</b>	<b>KPC1700</b>	<b>KPC1900</b>
<b>Mainboard</b>	<b>B78</b>			
CPU Support	Intel Celeron M 1.3 / 1.5GHz; Pentium M 1.8GHz;			
Chipset	Intel 852GM and ICH4 FSB 400 Mhz			
System Memory	2 x DDR SO-DIMM slot, up to 2GM			
Graphic Memory	Shared system memory 8 ~ 64MB			
BIOS	AWARD BIOS			
<b>LCD Touch Panel</b>				
LCD Size	12" TFT LCD	15" TFT LCD	17" TFT LCD	19" TFT LCD
Brightness	400nits	350nits	300nits	300nits
Maximal Resolution	800 x 600	1024 x 768	1280 x 1024	
Touch Screen Type	Resistive touch	Resistive type/, Intelligent SAW touch		
<b>Storage</b>				
HDD	2.5" Slim HDD bay			
Flash Memory	Optional Compact Flash memory (without HDD)			
<b>Expansion</b>				
Mini-PCI	1			
<b>External I/O Ports</b>				
USB 2.0	4			
Serial / COM	4 x RJ-45 (COM1 standard RS-232; COM2 RS232 / 422 / 485 selectable by Jumper; COM3 & COM4 pin 9 with 5V or 12V powered by Jumper)			
Parallel	1 x DB/ 25F			
LAN (10 / 100)	1 x RJ45			
Cash Drawer	1 x RJ-11 (12V or 24 V)			
DC Jack	1 x latch type			
Audio Jack	1 x Line-out, 1 x Line-in			
2nd VGA	1 X DB 15F			
<b>Internal Interface</b>				
USB 2.0	2			

<b>Power</b>		
Power Adapter	DC 19V, 90W	
<b>Audio</b>		
Speaker	1x3 W Speaker	2 x 3W speakers
<b>Environment</b>		
EMC & Safety	FCC, Class A, CE, LVD	
Operating Temperature	0°C~ 40°C (32°F~ 104°F)	
Storage Temperature	-20°C ~ 60°C (-4°F~ 140°F)	
Operating Humidity	5% ~ 95% RH non condensing	
Storage Humidity	5% ~ 95% RH non condensing	
Dust & Water Proof	NEMA 3 / IP 55	
Dimension (W x D x H mm/inch)	KPC1200: 330.8 x 265.3 x 55 mm	
	KPC1500: 385.9 x 307.4 x 60 mm	
	KPC1700: 410.5 x 344.5 x 60 mm	
	KPC1900: 449.2 x 374.2 x 60 mm	
Weight	KPC1200: N.W. 4.7 kg/ 10.4lbs	
	KPC1500: N.W. 5.8 kg/ 12.8 lbs	
	KPC1700: N.W. 7.6 kg/ 16.7 lbs	
	KPC1900: N.W. 9.0 kg/ 19.8 lbs	
Mounting	100mm x 100mm Standard VESA	
OS Support	Win XP Pro, XPe, WEPOS, Windows NT 4.0 / 2000	

- This specification is subject to change without prior notice.

# 6. Jumper Settings

## B78 Motherboard

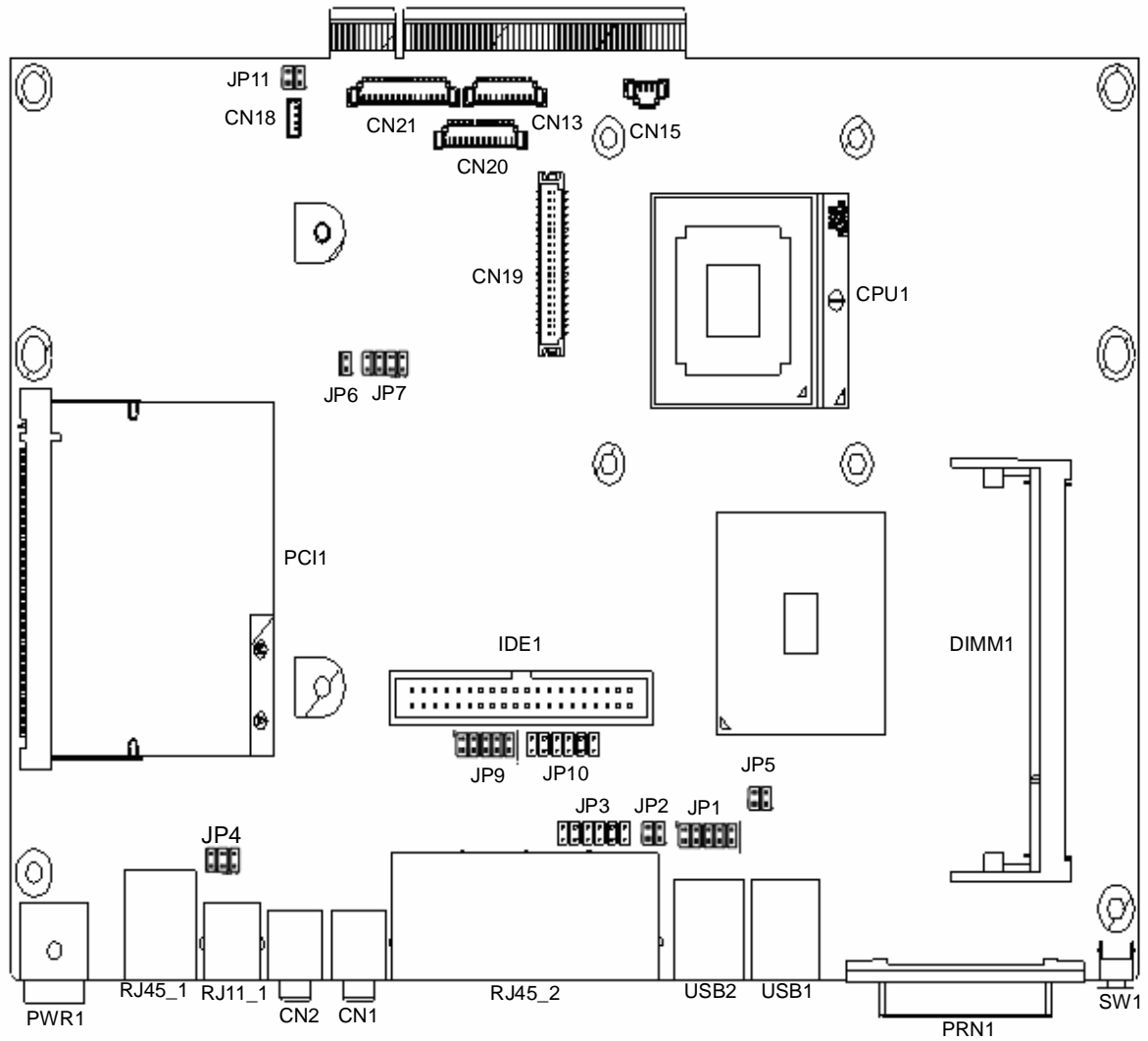

## 1. Connectors

Connector	Function
CN1	Audio Line Out
CN2	Audio Line In
CN13	COM5 for Touch
CN15	CPU FAN Connector
CN16	Hardware Reset
CN18	USB2
CN19	LCD Interface Connector
CN20	Inverter Connector
CN21	Card Reader Connector

Connector	Function
IED1	Primary IDE Connector
PRN1	Parallel Port
PWR1	+19V Power Adapter
RJ11_1	Cash Drawer Connector
RJ45_1	LAN (On Board)
RJ45_2	COM1, COM2, COM3, COM4
USB1	USB3, USB4
USB2	USB5, USB6

## 2. Jumper Settings

### 1. CMOS Operation Mode

Function	JP8
CMOS Normal	⊙N/C
CMOS Reset	1-2

To clear the CMOS:

- 1) Remove AC power from the unit.
- 2) Open the cabinet.
- 3) Change the JP8 jumper setting from N/C to 1-2.
- 4) Wait 1 minute.
- 5) Change the JP8 jumper setting back to N/C.
- 6) Close the cabinet.
- 7) Apply AC power and continue.

### 2. Power Mode Setting

Function	JP6
ATX Power	⊙N/C
AT Power	1-2

### 3. Cash Drawer Power Setting

Voltage	JP4
+12V	⊙1-2
+24V	3-4
+19V	5-6

### 4. COM3 & COM 4 Power Setting

Function	JP3
COM3 PIN10_RI	⊙1-2
COM3 PIN10_+5V	3-4
COM3 PIN10_+12V	5-6
COM4 PIN10_RI	⊙7-8
COM4 PIN10_+5V	9-10
COM4 PIN10_+12V	11-12

### 5. Card Reader Setting

Function	⊙Docking	On Board
JP11 (1-2)	N/C	1-2
JP11 (3-4)	N/C	3-4

### 6. LCD ID Setting

Panel Number	Resolution	LVDS		JP7			
		Bits	Channel	1-2	3-4	5-6	7-8
0	640 x 480	18	Single	SHORT	SHORT	SHORT	SHORT
1	800 x 600	18	Single	SHORT	SHORT	SHORT	OPEN
2	1024 x 768	18	Single	SHORT	SHORT	OPEN	SHORT
3	1280 x 1024	24	Dual	SHORT	SHORT	OPEN	OPEN
4	1024 x 768	24	Single	SHORT	OPEN	SHORT	SHORT
5	800 x 600	24	Single	SHORT	OPEN	SHORT	OPEN

### 7. COM2 RS232 / 485 / 422 Setting

Function	⊙RS232	RS485	RS422
JP9 (1-2)	V		
JP9 (3-4)	V		
JP9 (4-6)		V	
JP9 (5-7)	V		
JP9 (7-8)		V	
JP9 (9-10)			V
JP10 (1-2)	V		
JP10 (3-4)		V	
JP10 (5-6)			V
JP10 (7-8)			V
JP10 (9-10)			V
JP10 (11-12)			V

Note:      OPEN      SHORT



### 3. Connectors Pin Definition

#### CN4: Speaker & MIC Connector

Pin 1	AMP_ORL	Pin 2	GND
Pin 3	GND	Pin 4	AMP_ORR
Pin 5	GND	Pin 6	MIC1

#### CN9: CD-IN Connector

Pin 1	CDIN_L	Pin 2	CDIN_REF
Pin 3	CDIN_R	Pin 4	CDIN_REF

#### CN11: Power Connector For 3.5" HDD

Pin 1	+12V	Pin 2	GND
Pin 3	GND	Pin 4	+5V

**CN13: COM5**

Pin 1	DCD#
Pin 3	TX#
Pin 5	GND
Pin 7	RTS#
Pin 9	RI

Pin 2	RX#
Pin 4	DTR#
Pin 6	DSR#
Pin 8	CTS#
Pin 10	+5V

**CN15: CPU FAN Connector**

Pin 1	+5V
Pin 3	GND

Pin 2	Feedback
-------	----------

**CN18: USB 2**

Pin 1	+5V_USB1
Pin 3	USB20_R_P1+

Pin 2	USB20_R_P1
Pin 4	GND

**CN19: LVDS Interface**

Pin 1	LVDS_B0+
Pin 3	LVDS_B0-
Pin 5	GND
Pin 7	LVDS_B1+
Pin 9	LVDS_B1-
Pin 11	GND
Pin 13	LVDS_B2+
Pin 15	LVDS_B2-
Pin 17	GND
Pin 19	LVDS_B3+
Pin 21	LVDS_B3-
Pin 23	GND
Pin 25	LVDS_CLKB+
Pin 27	LVDS_CLKB-
Pin 29	GND
Pin 31	+5V_LCDVDD
Pin 33	+5V_LCDVDD
Pin 35	+5V_LCDVDD
Pin 37	+5V_LCDVDD
Pin 39	+5V_LCDVDD

Pin 2	LVDS_A3+
Pin 4	LVDS_A3-
Pin 6	GND
Pin 8	LVDS_CLKA+
Pin 10	LVDS_CLKA-
Pin 12	GND
Pin 14	LVDS_A2+
Pin 16	LVDS_A2-
Pin 18	GND
Pin 20	LVDS_A1+
Pin 22	LVDS_A1-
Pin 24	GND
Pin 26	LVDS_A0+
Pin 28	LVDS_A0-
Pin 30	GND
Pin 32	+3.3V_LCDVDD
Pin 34	+3.3V_LCDVDD
Pin 36	+3.3V_LCDVDD
Pin 38	+3.3V_LCDVDD
Pin 40	+3.3V_LCDVDD

**CN20: Inverter Connector**

Pin 1	+12V_INV
Pin 3	+12V_INV
Pin 5	Back-Light Enable
Pin 7	N/C
Pin 9	GND
Pin 11	GND

Pin 2	+12V_INV
Pin 4	+12V_INV
Pin 6	N/C
Pin 8	Back-Light Enable
Pin 10	GND
Pin 12	GND

**CN21: POS Card Reader Connector**

Pin 1	+5V
Pin 3	KDATA_SIO_TO_MSR
Pin 5	KDATA_MSR_TO_GFINGER
Pin 7	RS232_6_RX#
Pin 9	RS232_6_CTS#
Pin 11	KB_EN
Pin 13	USB20_MSR_P0+
Pin 15	GND

Pin 2	+5V
Pin 4	KDATA_SIO_TO_MSR
Pin 6	KCLK_MSR_TO_GHINGER
Pin 8	RS232_6_TX#
Pin 10	RS232_6_RTS#
Pin 12	GND
Pin 14	USB20_MSR_P0-

**CN22: System FAN Connector**

Pin 1	+5V
Pin 3	GND

Pin 2	Feedback
-------	----------

**CN23: IrDA Connector**

Pin 1	+5V
Pin 3	IRDA_TX

Pin 2	IRDA_RX
Pin 4	GND

**RJ45\_2: COM1, COM2, COM3, COM4**

Pin 1	N/C
Pin 3	RS232_1_DSR#
Pin 5	RS232_1_RTS#
Pin 7	RS232_1_CTS#
Pin 9	GND
Pin 11	N/C
Pin 13	RS232_2_DSR#
Pin 15	RS232_2_RTS#
Pin 17	RS232_2_CTS#
Pin 19	GND

Pin 2	RS232_1_DCD#
Pin 4	RS232_1_RX#
Pin 6	RS232_1_TX#
Pin 8	RS232_1_DTR#
Pin 10	RS232_1_RI
Pin 12	RS232_2_DCD#
Pin 14	RS232_2_RX#
Pin 16	RS232_2_TX#
Pin 18	RS232_2_DTR#
Pin 20	RS232_2_RI

**RJ45\_2: COM1, COM2, COM3, COM4**

Pin 21	N/C	Pin 22	RS232_3_DCD#
Pin 23	RS232_3_DSR#	Pin 24	RS232_3_RX#
Pin 25	RS232_3_RTS#	Pin 26	RS232_3_TX#
Pin 27	RS232_3_CTS#	Pin 28	RS232_3_DTR#
Pin 29	GND	Pin 30	RS232_3_RI
Pin 31	N/C	Pin 32	RS232_4_DCD#
Pin 33	RS232_4_DSR#	Pin 34	RS232_4_RX#
Pin 35	RS232_4_RTS#	Pin 36	RS232_4_TX#
Pin 37	RS232_4_CTS#	Pin 38	RS232_4_DTR#
Pin 39	GND	Pin 40	RS232_4_RI

**JP1: VGA Port**

Pin 1	GND	Pin 2	CRT_R
Pin 3	GND	Pin 4	CRT_G
Pin 5	GND	Pin 6	CRT_B
Pin 7	GND	Pin 8	CRT_HSYNC
Pin 9	GND	Pin 10	CRT_VSYNC

**JP2: VGA Power**

Pin 1	+12	Pin 2	GND
Pin 3	+12	Pin 4	GND

## 7. BIOS Settings

### 1. BIOS Setup Utility

The BIOS setup defines how the system is configured. You need to run this program the first time you configure this product. You may need to run it again if you change the configuration.

You need to connect a PC keyboard to the keyboard connector to run the BIOS setup utility.

### 2. Starting the BIOS Setup

1. Turn on or reboot this product.
2. Press the DEL key immediately after the product is turned on, or press the DEL key when the following message is displayed during POST (the Power on Self-Test).

***Press DEL to enter SETUP.***

3. The main menu of the BIOS setup is displayed.
4. If the supervisor password is set, you must enter it here.

### 3. When a Problem Occurs

If, after making and saving system changes with the Setup utility, you find that this product no longer boots, start the BIOS setup and execute the following.

***Load Optimized Defaults***

### 4. BIOS Main Menu

When the BIOS Main Menu is displayed, the following items can be selected. Use the arrow keys to select items and the Enter key to accept and enter the sub-menu.

Note: The BIOS menu below is from B78 BIOS version. If you have a different BIOS version, the contents of the menu may differ.

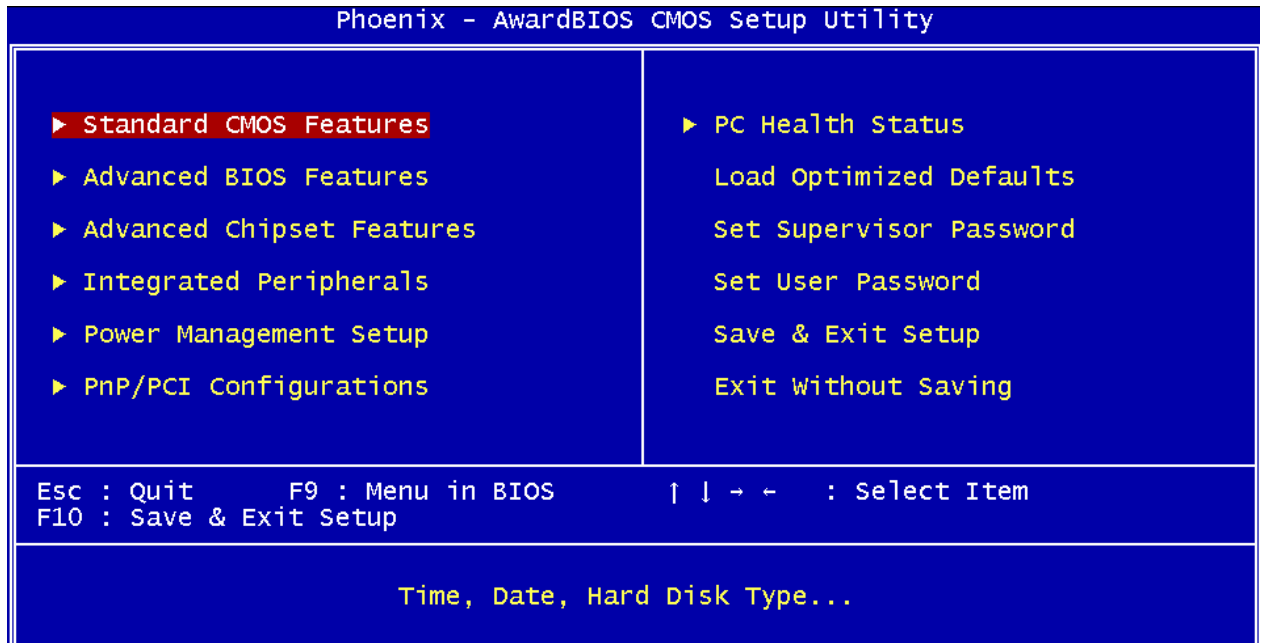

### **Standard CMOS Features**

Use this menu for basic system configuration.

### **Advanced BIOS Features**

Use this menu to set the Advanced Features available on the system.

### **Advanced Chipset Features**

Use this menu to change the values in the chipset registers and optimize the system's performance.

### **Integrated Peripherals**

Use this menu to specify your settings for integrated peripherals.

### **Power Management setup**

Use this menu to specify your settings for power management.

### **PnP/PCI Configurations**

This entry appears if your system supports Plug and Play and PCI Configuration.

### **PC health status**

Displays CPU, System Temperature, Fan Speed, and System Voltages Value.

### **Load Optimized Defaults**

Use this menu to load the BIOS default values, i.e., factory settings for optimal performance system operations. While Award has designed the custom BIOS to maximize performance, the factory has the option to change these defaults to meet their needs.

**Set Supervisor Password**

Enables you to change, set, or disable the supervisor or user password.

**Set Password**

Change, set, or disable the password. It allows you to limit access to the system and to the setup, or just to the setup.

**Save & exit setup**

Save CMOS value changes to CMOS and exits setup.

**Exit without saving**

Ignores all CMOS value changes and exits setup.

## 8. Airflow Requirements

Do not block the air vents on the CPU. These vents are necessary for cooling purposes.

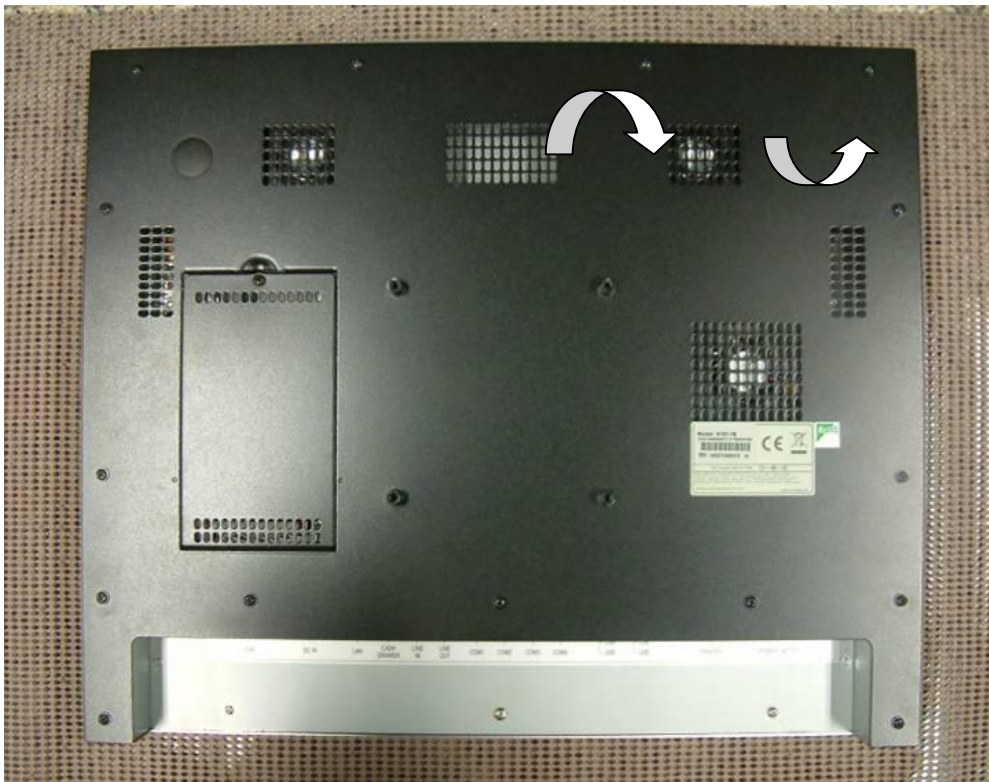

Do not place the CPU in an enclosed area where sufficient ventilation is not available. Leave at least 150 mm (6 in.) of clearance on the sides where air vents are located.