

Embedded & Industrial Computing

Hardware Platforms for Embedded and Industrial Computing

LPC8800 User's Manual



i-Tech Company LLC

TOLL FREE: (888) 483-2418 • EMAIL: info@itechlcd.com • WEB: www.iTechLCD.com

Overview

Icon Descriptions

The icons are used in the manual to serve as an indication of interest topics or important messages. Below is a description of these icons:



NOTE: This check mark indicates that there is a note of interest and is something that you should pay special attention to while using the product.



WARNING: This exclamation point indicates that there is a caution or warning and it is something that could damage your property or product.

Online Resources

The listed websites are links to the on-line product information and technical support.

Resource	Website
iTechLCD	http://www.i-techcompany.com
Product Resources	http://www.i-techcompany.com/support-top.html
RMA	http://www.i-techcompany.com/online-rma-request-form.html

Copyright and Trademarks

This document is copyrighted ©2014. All rights are reserved. The original manufacturer reserves the right to make improvements to the products described in this manual at any time without notice.

No part of this manual may be reproduced, copied, translated or transmitted in any form or by any means without the prior written permission of the original manufacturer. Information provided in this manual is intended to be accurate and reliable. However, the original manufacturer assumes no responsibility for its use, nor for any infringements upon the rights of third parties that may result from such use.

Acknowledgement

Intel, Pentium and Celeron are registered trademarks of Intel Corp.

Microsoft Windows and MS-DOS are registered trademarks of Microsoft Corp.

All other product names or trademarks are properties of their respective owners.

Compliances and Certification

CE Certification

This product has passed the CE test for environmental specifications. Test conditions for passing included the equipment being operated within an industrial enclosure. In order to protect the product from being damaged by ESD (Electrostatic Discharge) and EMI leakage, we strongly recommend the use of CE-compliant industrial enclosure products.

FCC Class A Certification

This equipment has been tested and found to comply with the limits for a Class A digital device, pursuant to Part 15 of the FCC Rules. These limits are designed to provide reasonable protection against harmful interference when the equipment is operated in a commercial environment. This equipment generates, uses and can radiate radio frequency energy and, if not installed and used in accordance with the instruction manual, may cause harmful interference to radio communications. Operation of this equipment in a residential area is likely to cause harmful interference in which case the user will be required to correct the interference at his own expense.

Revision History

Version	Changes
V1.0	Change the J1(PEG 16X lane Configuration) pin definitions



Table of Contents

Chapter 1: Introduction	4
System Specification	4
Package Contents	5
Optional Accessories	5
Chapter 2: System Components	6
System Drawing	6
Block Diagram	7
Front Components.	8
Rear Components	9
Chapter 3: Board Layout	10
Connectors	10
External Connectors.	11
Internal Connectors and Jumpers	12
Internal Connectors and Jumpers (backside)	13
Connectors and Jumpers List.	14
Jumper Settings	15
Chapter 4: Hardware Setup	21
Preparing the Hardware Installation.	21
Installing the System Memory	21
Wireless Module Installation	22
3G SIM Card Installation	22
PCI/PCIe Riser Card Installation	22
On LPC8800-xxB1 with one PCIe slot	22
Installing the Hard Disk.	23
On LPC8800-xxB2 with 2 PCI slot.	23
Connecting Power	24
Wall Mounting	24
Appendix A: Programming System Watchdog Timer	25
Appendix B: Terms and Conditions	26
Warranty Policy	26
RMA Service	26

Chapter 1: Introduction

Thank you for choosing the LPC8800. The LPC8800 is an upgrade platform of Lanner LPC8800 and features Intel Ivy Bridge i3, i5, and i7 processors. It has dual LAN as well as HDMI and DVI-D connectors for high demand of Internet and video playback applications. The LPC8800 also features slim and compact chassis design to allow heat to dissipate off directly from the top of the platform.

The LPC8800 also offers a variety of different expansion opportunities to further customize the platform. Two different expansions are possible.

On model LPC8800-xxB1, it comes with one PCIe.

On model LPC8800-xxB2, it comes with 2 PCI slots.

These expansions adds capabilities of video capture or extended LAN connections.

The following highlight the functionalities of the LPC8800 system:

- Intel HD Graphics Engine
- Dual video output of VGA and HDMI or VGA and DVI-D with Intel integrated HD graphic engine
- Dual 10/100/1000 Mbps LAN
- USB x 6 (2 by internal pin header) and COM x 2
- 1 SATA 6Gbps HDD bay support and 1 SATA-DOM connector
- Totally 2 serial ports supporting Hardware Auto flow Control: DB9 x2 for RS232/422/485
- Audio input and output through Mic-in and Line-out jack
- Dual Mini-PCIe Socket (with on SIM card reader for 3G wireless Internet connection) can extend the capability for Wi-Fi or Bluetooth
- Aluminum extrusion enclosure which helps heat dissipation
- Customization opportunity for expansion of extra LAN and serial port (board LEK-IOA5) or eSATA and DI/DO (LEK-IOA3)

System Specification

Dimensions (WxHxD)		277x(67/89)x194mm (10.91"x(2.64/3.50)"x7.64")
Processor		i5-3610ME/i3-3120ME (Ivy Bridge), i7-3612QE, i7-3555LE
Chipset		Intel HM65
System Memory	Technology	DDR3 SO-DIMM x2
	Max. Capacity	Up to 16GB
Storage	IDE	N/A
	SATA	2.5" SSD/HDD drive bay x1, SATA-DOM x1
Ethernet Controller		Intel 82574L x2
Graphic Controller		Intel integrated HD graphic engine
Audio Controller		ALC886
IO	LAN	RJ45 10/100/1000Mbps x2
	Display	HDMI x1 , DVI-D x1 , VGA x1
	Dual Display	VGA+HDMI, VGA+DVI
	Dual Display Mode	Clone, Independent, Extend
	Audio	Phone Jack x2 for Mic-In and Line-Out
	Serial I/O	DB9 x2 for RS232/422/485
	Digital I/O	DB9 Female x1 for DI x4 & DO x4 (TTL, DO Max 100ma) - optional
	USB 2.0	Type A x6
	Power Input	Terminal Block 2-pin
	Expansion	Mini-PCIe x1 with SIM card reader Mini-PCIe x1 PCI x 2 or PCIe (x1) x 1
Power Input		+9~+30v Input, Support ATX Function
Hardware Monitor		Fintek F81865 integrated Watchdog Timer 1~255 level
OS Support		Win7/XP/7Embedded/XP Embedded, Redhat Enterprise 5/Fedora 14, Linux Kernel 2.6.18 or Later
Certifications		CE, FCC Class A
Operating Temperature Range	With Industrial Components	-10 to +45°C/14~113°F for processor power consumption of 35W -10 to +50°C/14~122°F for processor power consumption below 25W
	With Commercial Components	-5~45°C / 23~113°F
	High/Low Extended Temperature Tested	Bootable after 24 hours @ -40°C
Ordering Information		
LPC8800-xxB1	Intel i5/i7/Celeron on-board CPU, 2 DDR3 SO-DIMM Sockets, 2 COM Ports, 1 HDMI, 1 DVI-D, 1 VGA, Audio Ports 2 LAN Ports, DIO (4 in, 4 out) – optional +9~30V DC input support with one PCIe expansion	
LPC8800-xxB2	Intel i5/i7/Celeron on-board CPU, 2 DDR3 SO-DIMM Sockets, 2 COM Ports, 1 HDMI, 1 DVI-D, 1 VGA, Audio Ports 2 LAN Ports, DIO (4 in, 4 out) – optional +9~30V DC input support with two PCI expansion	

Chapter 1

Introduction

Package Contents

Your package contains the following items:

- LPC8800 Fanless Embedded System
- Serial-ATA/Power Cable (P/N: 080W1N0002001)
- Wall-Mounting Kit (P/N: SE9ESA900R100)
- Drivers and User's Manual CD (087W0200V1001)
- Power Adapter (P/N: 0P0W075190001)

Optional Accessories

The system has a variety of optional accessories including the power cords and Wi-Fi or 3G modules for extended capabilities. For details of these modules, visit:

<http://www.i-techcompany.com/embedded-system-intel-i7-lpc8800-i7b2.html>

Chapter 2: System Components

System Drawing

Mechanical dimensions of the LPC8800

Unit: mm

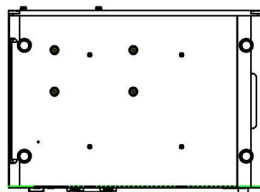
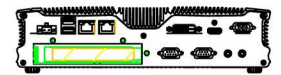
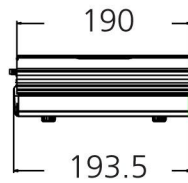
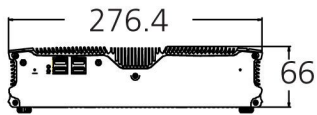
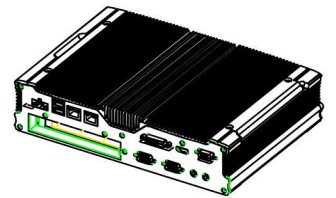
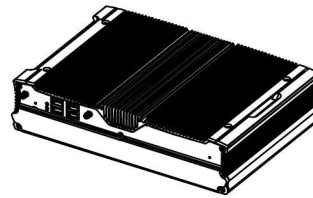
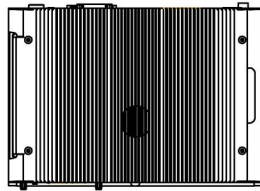

Block Diagram

The block diagram depicts the relationships among the interfaces and modules on the motherboard.

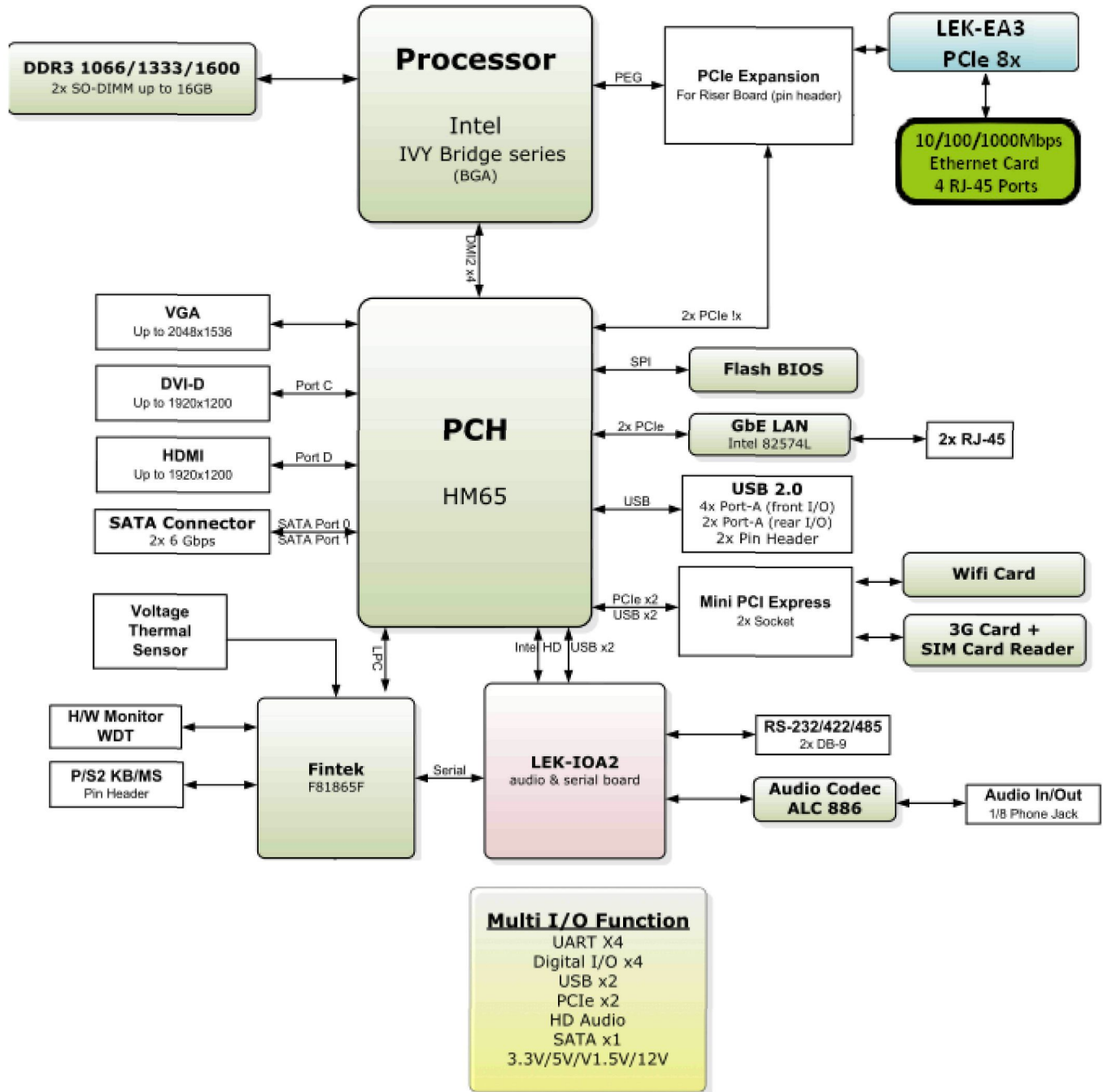

Front Components



Component	Description	Pin Definition Reference
F1 HDD (Yellow) and Power LED (Green)	HDD <ul style="list-style-type: none"> Blinking: data access activities Off: no data access activities Power <ul style="list-style-type: none"> On: The computer is on. Off: The computer is off . 	
F2 Four USB 2.0 Ports	<ul style="list-style-type: none"> An USB type A connector. In addition to this connector, an internal pin header is also provided. 	USB1, USB2 on Page 17
F3 Reset	Reset switch	RST1 on page 19

Rear Components

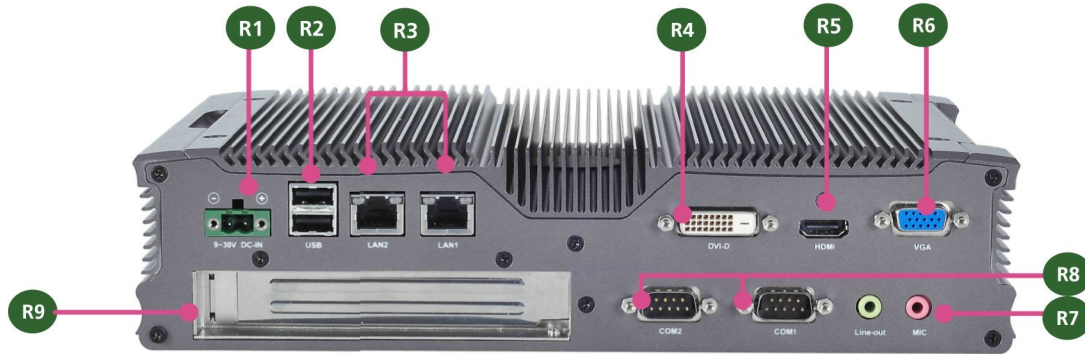

Component	Description	Pin Definition Reference
R1 DC-In (power) 1x2 Pin Phoenix Contact Connector	Power-in Connector. The LPC8800 support power range between +9~+30V DC-in.	CN4 on page 19
R2 Two USB 2.0 Ports	An USB type A connector. In addition to this connector, an internal pin header is also provided..	USB3 Connector on Page 17
R3 Two 10/100/1000Mbps LAN ports	Two RJ-45 (network) jacks with LED indicators as described below. The LAN ports are provided by Intel 82574L. They both support WOL/Remote-wake-up/PXE function. LINK/ACT (Yellow) <ul style="list-style-type: none"> On/Flashing: The port is linking and active in data transmission. Off: The port is not linking. SPEED (Green/Amber) <ul style="list-style-type: none"> Amber: The connection speed is 1000Mbps. Green: The connection speed is 100Mbps Off: .The connection speed is 10Mbps. 	LAN1/LAN2 on page 20
R4 DVI-D	A DVI-D port (single link) which is provided by Intel HD Graphic Engine. This port can support up to 1920x1200 @ 60 Hz resolution.	DVID1 Connectors on page 18
R5 HDMI	A HDMI (High-Definition Multimedia Interface).This port can support up to 1920x1200 @ 60 Hz resolution.	HDMI1 on page 18
R6 VGA Port(†)	The displays can support VGA up to 2048x1536 resolution.	VGA1 on page 18
R7 MIC IN/LINE OUT(†)	Connect the audio devices to these ports. The Microphone and line out port are provided by Realtek ALC ALC886.	CN1, CN2 on page 15
F8 Serial Ports	Serial ports through the DB-9 connector; Both COM1 and COM2 support RS-232/422/485 with jumper selection among RS-232/422/485.	COM1/COM2 on page 15
R9 Slot for PCIe expansion (*)	The PCIe/PCI expansion capability is accomplished via the riser card connected to the system	PCIEIO1 Connector on page 18
†Note that the driver for these ports should be installed with the following order: Chipset INF->Graphic->Audio * Model LPC8800-xxB2 can support 2 PCI expansion.		

Chapter 3: Board Layout

Connectors

The following picture highlights the location of the COM port and audio expansion card. Refer to the table 3.1 Connector List for more details.

Note: Daughter boards such as COM ports and low-profile PCIe extension boards can only be inserted to the mainboards with the same version. Failure to do so may damage the system. The board version is shown on top of the boards.

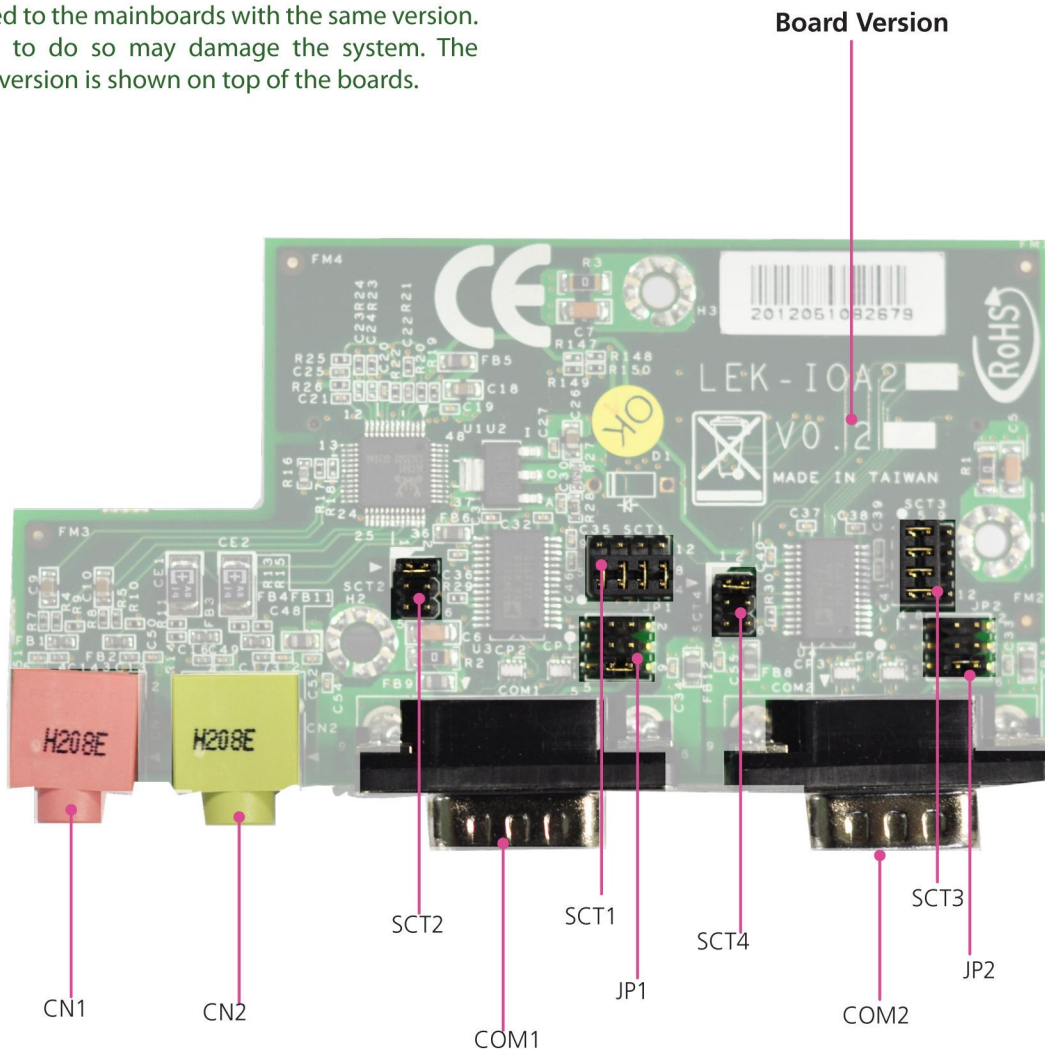

LEK-IOA2

External Connectors

The following picture highlights the location of system input/output connectors. Refer to the table 3.2 Connector List for more details.

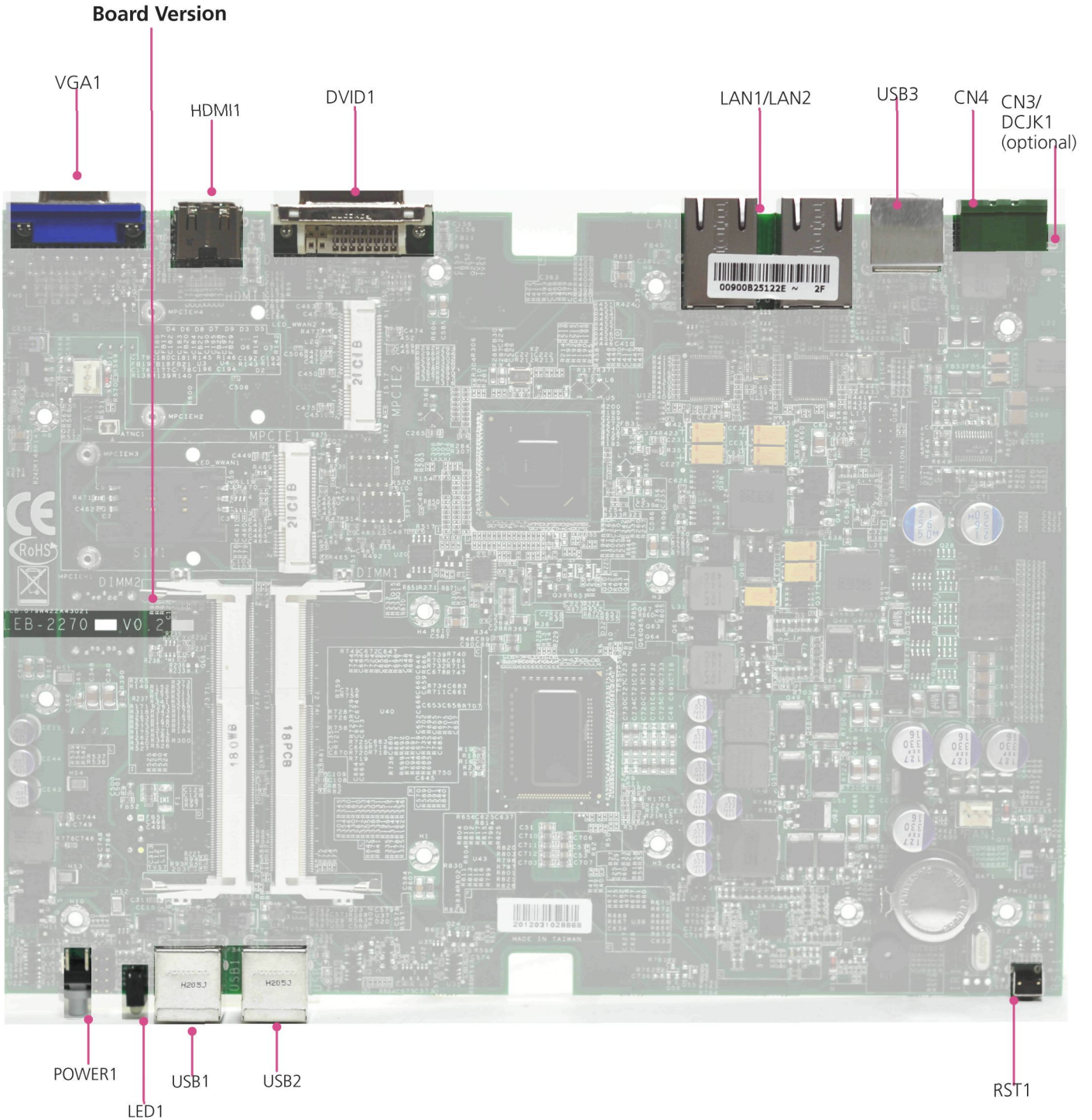

LEB-2280

Internal Connectors and Jumpers

The following picture highlights the location of internal connectors and jumpers. Refer to the table 3.2 Connector List for more details.

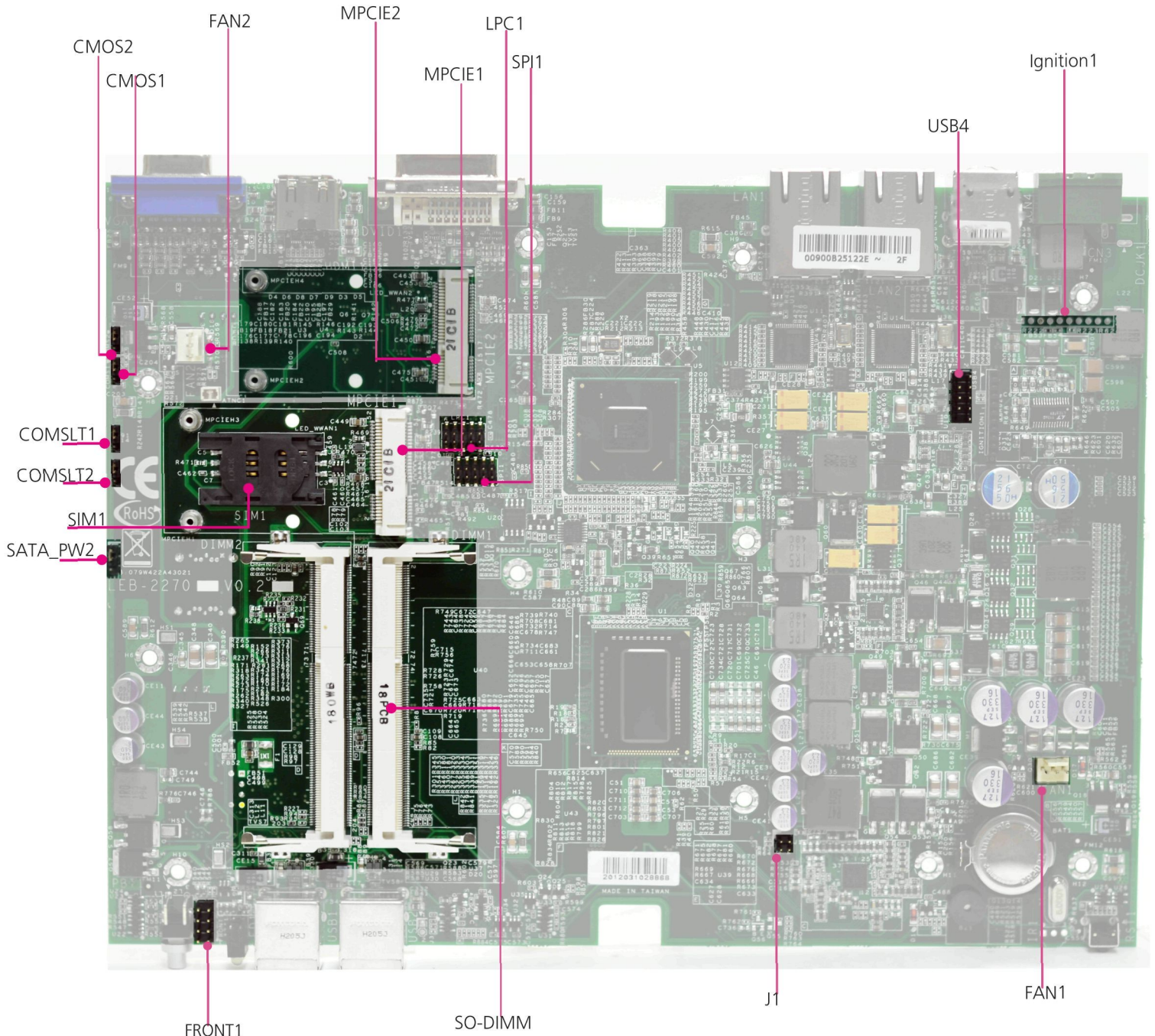

LEB-2280

Internal Connectors and Jumpers (backside)

The following picture highlights the location of internal connectors and jumpers on the backside of the board. Refer to the table 3.2 Connector List for more details.

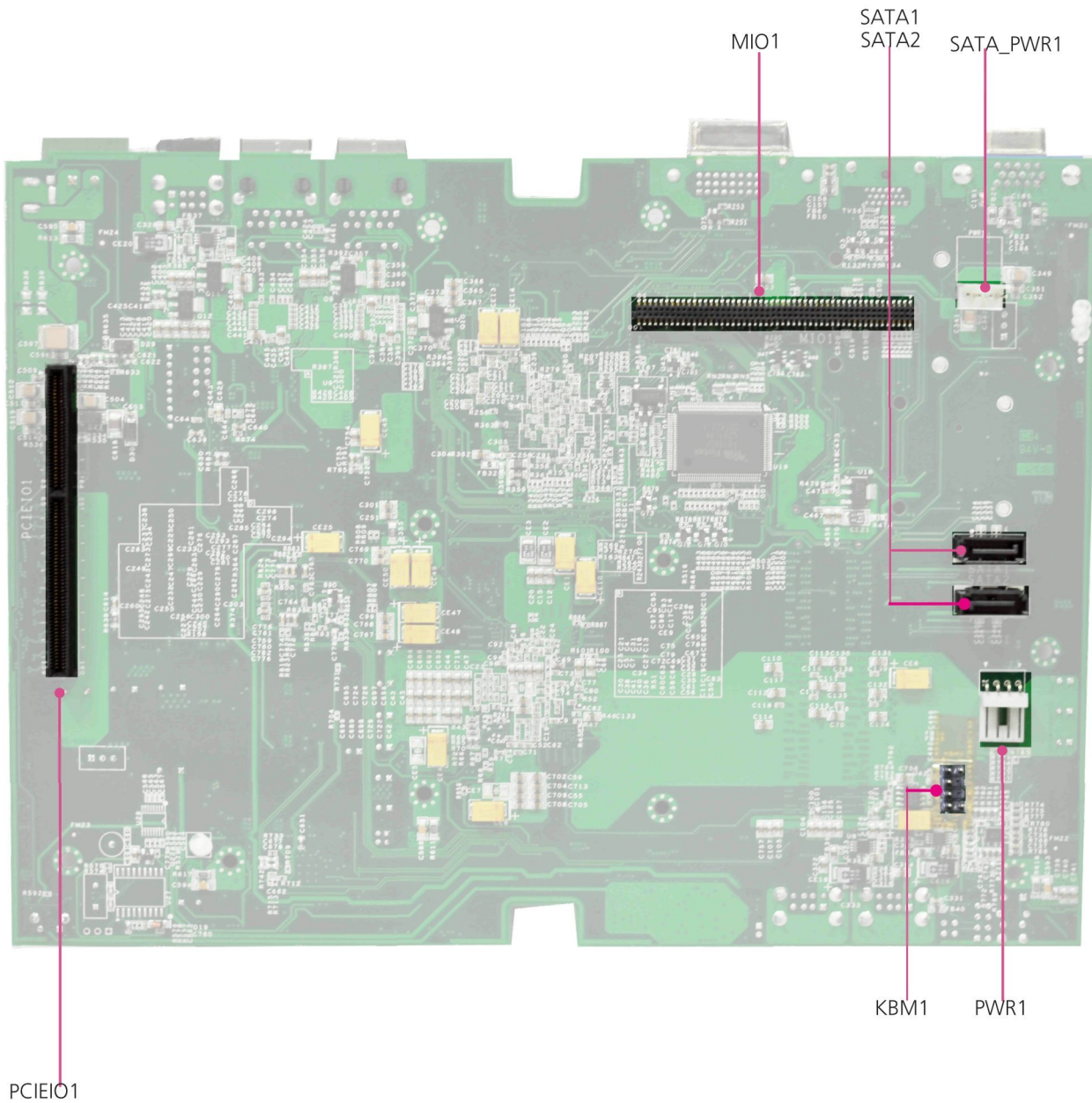

LEB-2280

Connectors and Jumpers List

The tables below list the function of each of the board jumpers and connectors by labels shown in the above section. The next section in this chapter gives pin definitions and instructions on setting jumpers.

Table 3.1 Connector List for **LEK-IOA2** Board

Labels	Function	Pin Definition Reference Page
CN1	Microphone-in Audio Jack	P15
CN2	Line-out Audio Jack	P15
COM1	RS232/422/485 Serial Port	P15
COM2	RS232/422/485 Serial Port	P15
MIO1	Connector for connecting the COM port and audio expansion board to the LEC-2280 main board	P16
SCT1/SCT2	Select COM1 Protocol Setting	P15
SCT3/SCT4	Select COM2 Protocol Setting	P15
JP1	Select COM1 Pin No. 9 function	P16
JP2	Select COM2 Pin No. 9 function	P16
<p>Note: Daughter boards such as COM ports and low-profile PCIe extension boards can only be inserted to the mainboards that has the same version as the extension boards. The board version is shown on top of the boards. Failure to do so may damage the system.</p>		

Table 3.2 Connector List for **LEB-2280** Board

Labels	Function	Pin Definition Reference Page
CMOS1	Cleaning CMOS data including RTC	P16
CMOS2	Cleaning CMOS data only	P16
COMSLT1	Daughter board LEK-IOA3 enable/disable	P20
COMSLT2	Daughter board LEK-IG1 enable/disable	P20
CN3 (optional)	Optional Power Connector with Power -ignition Control	P20
CN4	DC-in Power Connector	P19
DCJK1 (optional)	Optional DC Jack type of Power Connector	P20
DVID1	DVI-D Connector	P18
FAN1/FAN2	System Fan Connector	P18
Front1	Front Panel Function Pin Header	P17
HDMI1	HDMI Port	P18
Ignition1 (optional)	Connector for power Ignition Control	P20
J1	PEG16X Lane Function Selection	P19
LAN1/LAN2	Ethernet Connector 1/Ethernet Connector 2	P20
LPC1	Low Pin Count Interface	Reserved for factory use
KBM1	Keyboard and Mouse Connector	P20
MIO1	COM and Audio Expansion Card Connector	P17
MPCIE1	Mini-PCIe Connector	P19
MPCIE2	Mini-PCIe Connector	P19
PCIEIO1	PCI/PCIe Expansion connector for PCI or PCIe low profile card (PCIEIO1, on the backside)	P18
PWR1	Right-angled SATA Power Connector	P17
RST1	Reset Button	P19
SATA1/SATA2	Serial-ATA Connector (SATA2 supports SATA-DOM)	P16
SATA_PW2	Switch for SATA port 2 power state	P21
SATA_PWR1	SATA Power Connector	P17
SIM1	SIM Card Reader	P17
SPI1	Serial Peripheral Interface Bus	Reserved for factory use
USB1/USB2/USB3	USB Type A Connector #0,1; #2,3; #4,5	P17
USB4	USB Pin Header	P17
VGA1	VGA Port	P18

Jumper Settings

LEK-IOA2 Board

Microphone-in Audio Jack (CN1)

Pin No.	Function
1	CO_GND
2	MIC_INL
3	CO_GND
4	INSULATOR
5	MIC_INR

Line-out Audio Jack (CN2)

Pin No.	Function
1	CO_GND
2	LINOUT-L
3	CO_GND
4	INSULATOR
5	LINOUT-R



Note: The driver for the VGA and Audio ports should be installed with the following order: Chipset INF->Graphic->Audio

COM1 RS-232 Serial Port(COM1): It is a RS-232/422/485 port through the D-SUB9 connector.

1 2 3 4 5

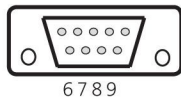

Pin No.	Pin Name		
	RS-232	RS-422	RS-485
1	DCD	TXD-	DATA-
2	RXD	TXD+	DATA+
3	TXD	RXD+	
4	DTR	RXD-	
5	GND		
6	DSR		
7	RTS		
8	CTS		
9	RI		

RS-232/422/485 Serial Port(COM2): It is a RS-232/422/485 port through the D-SUB9 connector.

Pin No.	Pin Name		
	RS-232	RS-422	RS-485
1	DCD	TXD-	DATA-
2	RXD	TXD+	DATA+
3	TXD	RXD+	
4	DTR	RXD-	
5	GND		
6	DSR		
7	RTS		
8	CTS		
9	RI		

SCT1, SCT2: Select COM1 Protocol Setting

SCT1

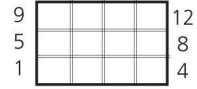

SCT2

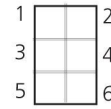

RS-232

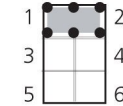
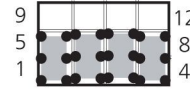

RS-422

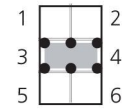
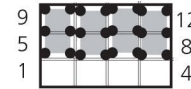

RS-485

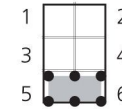
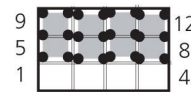

Switch	SCT1	SCT2
Protocol		
RS-232 (default)	1-5, 2-6, 3-7, 4-8	1-2
RS-422	5-9, 6-10, 7-11, 8-12	3-4
RS-485	5-9, 6-10, 7-11, 8-12	5-6

SCT3, SCT4: Select COM2 Protocol Setting

SCT3

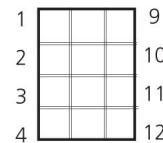

SCT4

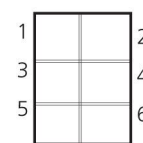

Switch	SCT3	SCT4
Protocol		
RS-232 (default)	1-5, 2-6, 3-7, 4-8	1-2
RS-422	5-9, 6-10, 7-11, 8-12	3-4
RS-485	5-9, 6-10, 7-11, 8-12	5-6

JP1, JP2: Select COM1 and COM2 Pin No9 (Ring Indicator) function respectively

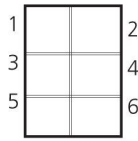

JP1		JP2	
Pin	Signal	Pin	Signal
1-2	VCC5	1-2	VCC5
3-4	VCC12	3-4	VCC12
5-6	SPI_RI	5-6	SPI_RI

MIO1 on the expansion card: Connector for connecting the COM port and audio expansion board to the LPC8800 main board.

PIN	Pin Name	PIN	Pin Name
1	GND	51	HDA_BCLK
2	N/A	52	HDA_SYNC
3	N/A	53	HDA_RST
4	GND	54	HDA_SDIN0
5	N/A	55	HDA_SDO
6	N/A	56	SPK
7	GND	57	GND
8	VCC5	58	VCC3
9	VCC5	59	VCC3
10	N/A	60	N/A
11	GND	61	GND
12	N/A	62	N/A
13	N/A	63	N/A
14	N/A	64	N/A
15	N/A	65	N/A
16	N/A	66	N/A
17	N/A	67	N/A
18	GND	68	GND
19	N/A	69	N/A
20	N/A	70	N/A
21	GND	71	N/A
22	+12V	72	N/A
23	N/A	73	N/A
24	VCC5	74	N/A
25	VCC5	75	GND
26	VCC5	76	N/A
27	VCC5	77	N/A
28	GND	78	GND
29	N/A	79	N/A
30	N/A	80	N/A
31	N/A	81	N/A
32	N/A	82	N/A
33	GND	83	GND
34	N/A	84	COM1_DCD#
35	N/A	85	COM1_RI#
36	N/A	86	COM1_CTS#
37	N/A	87	COM1_DTR#
38	N/A	88	COM1_RTS#
39	N/A	89	COM1_DSR#
40	N/A	90	COM1_SOUT
41	N/A	91	COM1_SIN
42	GND	92	GND
43	N/A	93	COM2_DCD#
44	N/A	94	COM2_RI#

45	N/A	95	COM2_CTS#
46	N/A	96	COM2_DTR#
47	N/A	97	COM2_RTS#
48	N/A	98	COM2_DSR#
49	N/A	99	COM2_SOUT
50	N/A	100	COM2_SIN



Note: Daughter boards such as COM ports and low-profile PCIe extension boards can only be inserted to the mainboards with the same version. Failure to do so may damage the system. The board version is shown on top of the boards.

LEB-2280 Board

Clear CMOS jumper (CMOS1/CMOS2): It is for clearing the CMOS data. CMOS 1 clears CMOS data with real-time clock (RTC) whereas CMOS2 clears CMOS data only.



Pin No.	Pin Name
1-2	Normal (Default)
2-3	Clear CMOS and RTC (CMOS1) Clear CMOS only (CMOS2)

To erase the CMOS data:

Turn off the computer and unplug the power cord.

1. Move the jumper cap from pins 1-2(default) to pins 2-3. Keep the cap on pins 2-3 for about 5-10 seconds, then move the cap back to pins 1-2.
2. Plug the power cord and turn on the computer.
3. Enter BIOS setup to re-enter data.

Serial-ATA Connector (SATA1/SATA2): It is for connecting a 2.5" hard disk to be served as your system's storage. It can support SATA 3.0 which features Data transfer rates up to 6.0 Gb/s (600 MB/s). SATA 2 connector also supports SATA-DOM (the power line of SATA-DOM can be disabled with a jumper on, see SATA_PW2).

1 2 3 4 5 6 7



7 6 5 4 3 2 1



Pin No.	Function
1	GND
2	TX0_P
3	TX0_N
4	GND
5	RX0_N
6	RX0_P
7	GND

Pin No.	Function
1	GND
2	TX1_P
3	TX1_N
4	GND
5	RX1_N
6	RX1_P
7	VCC5

The controller contains two modes of operation—a legacy mode using I/O space, and an AHCI mode using memory space. Software that uses legacy mode will not have AHCI capabilities.

The AHCI (Advanced Host Controller Interface) is a programming interface which defines transactions between the SATA controller and software and enables advanced performance and usability with SATA. Platforms supporting AHCI may take advantage of performance features such as no master/slave designation for SATA devices—each device is treated as a master—and hardware assisted native command queuing. AHCI also provides usability enhancements such as Hot-Plug.



Use the BIOS menu to configure your hard disk to be AHCI compatible.

4-pin Serial-ATA Power Connector (PWR1/SATA_PW1): It is for connecting the SATA power cable.



Pin No.	Function
1	+12V
2	GND
3	GND
4	+5V

Dual USB 2.0 Port Connector #0 and #1 (USB1)

Dual USB 2.0 Port Connector #2 and #3 (USB2)

Dual USB 2.0 Port Connector #4 and #5 (USB3)

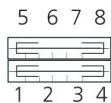

Pin No.	Pin Name
1	VCCUSB
2	USB0N
3	USB0P
4	GND
5	VCCUSB1
6	USB1N
7	USB1P
8	GND

USB 2.0 Pin Header (USB4):

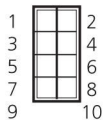

Pin No.	Pin Name	Pin No.	Pin Name
1	VCCUSB10	2	GND
3	N/A	4	USB11P
5	USB10N	6	USB11N
7	USB10P	8	N/A
9	GND	10	VCCUSB11

SIM Card Socket (SIM1):



Pin No.	Description
C1	UIM_PWR
C2	UIM_RST
C3	UIM_CLK
C5	GND
C6	UIM_VPP
C7	UIM_DAT

Front Panel Function Pin Header (FRONT1): It provides LED signal and button function on the front panel.

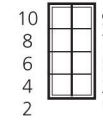

Pin No.	Pin Name	Function	Pin No.	Pin Name	Function
1	HD_LED+	HDD LED	2	PWR_LED+	Power LED
3	HD_LED-		4	PWR_LED-	
5	Reset	System Reset Button	6	POWER_BTN	Power On/Off
7	GND		8	GND	Push Button

Mini PCI Express Connector (MIO1) on the mainboard: COM and Audio Expansion Card Connector

PIN	Pin Name	PIN	Pin Name
1	GND	51	HDA_BCLK
2	SATATXN2	52	HDA_SYNC
3	SATATXP2	53	HDA_RST
4	GND	54	HDA_SDINO
5	SATARXN2	55	HDA_SDO
6	SATARXP2	56	SPK
7	GND	57	VCC3_SB
8	VCC3P3_PS	58	VCC3_SB
9	VCC3P3_PS	59	VCC3_SB
10	VCC3P3_PS	60	VCC3_SB
11	GND	61	VCC3_SB
12	PCIE_RXN5	62	PCIE_RXN6
13	PCIE_RXP5	63	PCIE_RXP6
14	PCIE_TXN5	64	PCIE_TXN6
15	PCIE_TXP5	65	PCIE_TXP6
16	PCIE_CKN5	66	PCIE_CKN6
17	PCIE_CKP5	67	PCIE_CKP6
18	IGN_DI2	68	IGN_DI1
19	PLTRST	69	SMBCLK
20	WAKE_N	70	SMBDATA
21	DCIN_VCC	71	REMOTE_POWER_ON
22	VCC12_PS	72	3G_POWER_ON
23	VCC5_SB	73	USB_N12
24	VCC5_SB	74	USB_P12
25	VCC5	75	GND
26	VCC5	76	USB_N13
27	VCC5	77	USB_P13
28	GND	78	GND
29	DGOUT_0	79	DGIN_0
30	DGOUT_1	80	DGIN_1
31	DGOUT_2	81	DGIN_2
32	DGOUT_3	82	DGIN_3
33	GND	83	GND
34	COM3_DCD#	84	COM1_DCD#
35	COM3_RI#	85	COM1_RI#
36	COM3_CTS#	86	COM1_CTS#
37	COM3_DTR#	87	COM1_DTR#
38	COM3_RTS#	88	COM1_RTS#
39	COM3_DSR#	89	COM1_DSR#
40	COM3_SOUT	90	COM1_SOUT
41	COM3_SIN	91	COM1_SIN
42	GND	92	GND
43	COM4_DCD#	93	COM2_DCD#
44	COM4_RI#	94	COM2_RI#
45	COM4_CTS#	95	COM2_CTS#
46	COM4_DTR#	96	COM2_DTR#
47	COM4_RTS#	97	COM2_RTS#
48	COM4_DSR#	98	COM2_DSR#
49	COM4_SOUT	99	COM2_SOUT
50	COM4_SIN	100	COM2_SIN

DVI-D Connector (DVID1): A single link DVI-D Connector

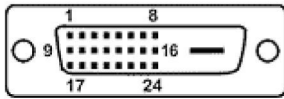

Pin No.	Description	Pin No.	Description
1	TXD_2-	2	TXD_2+
3	GND	4	N/A
5	N/A	6	DDC_CLK
7	DDC_DATA	8	N/A
9	TXD_1-	10	TXD_1+
11	GND	12	N/A
13	N/A	14	VCC5
15	GND	16	HPD
17	TXD_0-	18	TXD_0+
19	GND	20	N/A
21	N/A	22	GND
23	TXD_CLK_P	24	TXD_CLK_N

HDMI Connector (HDMI1): An HDMI Connector

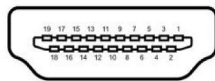

Pin No.	Description	Pin No.	Description
1	HDMI_DATP2_P	2	GND
3	HDMI_DATP2_N	4	HDMI_DATP1_P
5	GND	6	HDMI_DATP1_N
7	HDMI_DATP0_P	8	GND
9	HDMI_DATP0_N	10	HDMI_CLK_P
11	GND	12	HDMI_CLK_N
13	N/A	14	N/A
15	HDMI_DDC_CLK	16	HDMI_DDC_DAT
17	GND	18	PHDMI
19	HDMI_HPD		

VGA (VGA1)

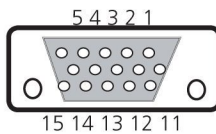

Pin	Signal	Pin	Signal	Pin	Signal
1	RED	6	CRT DET	11	N/A
2	GREEN	7	GND	12	DDC DAT
3	BLUE	8	GND	13	HSYNC
4	N/A	9	VCC5	14	VSYNC
5	GND	10	GND	15	DDC CLK



Note: The driver for the VGA and Audio ports should be installed with the following order: Chipset INF->Graphic->Audio

System FAN Connector (FAN1/FAN2)



Pin No.	Description
1	GND
2	VCC5
3	FAN TAC

PCI/PCIe Expansion connector for PCI or PCIe low profile card (PCIEIO1, on the backside)

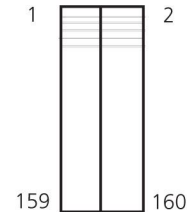

PIN	SIGNAL	PIN	SIGNAL	PIN	SIGNAL
1	VCC3P3_SB	53	PCIE_CKP1	105	PEG_RXP9
2	VCC5_SB	54	PCIE_TXP1	106	PEG_TXP9
3	VCC3P3_SB	55	PCIE_CKN1	107	GND
4	VCC5_SB	56	PCIE_TXN1	108	GND
5	N/A	57	GND	109	PEG_RXN8
6	N/A	58	GND	110	PEG_TXN8
7	VCC3P3	59	PEGACLKN	111	PEG_RXP8
8	V1P5	60	PEGBCLKN	112	PEG_TXP8
9	VCC3P3	61	PEGACLKP	113	GND
10	N/A	62	PEGBCLKP	114	GND
11	VCC3P3	63	GND	115	PEG_RXN7
12	VCC5	64	GND	116	PEG_TXN7
13	VCC3P3	65	GND	117	PEG_RXP7
14	VCC5	66	GND	118	PEG_TXP7
15	VCC3P3	67	PEG_RXN15	119	GND
16	VCC5	68	PEG_TXN15	120	GND
17	VCC3P3	69	PEG_RXP15	121	PEG_RXN6
18	VCC5	70	PEG_TXP15	122	PEG_TXN6
19	N/A	71	GND	123	PEG_RXP6
20	VCC5	72	GND	124	PEG_TXP6
21	GND	73	PEG_RXN14	125	GND
22	VCC5	74	PEG_TXN14	126	GND
23	N/A	75	PEG_RXP14	127	PEG_RXN5
24	N/A	76	PEG_TXP14	128	PEG_TXN5
25	+12V	77	GND	129	PEG_RXP5
26	GND	78	GND	130	PEG_TXP5
27	+12V	79	PEG_RXN13	131	GND
28	GND	80	PEG_TXN13	132	GND
29	+12V	81	PEG_RXP13	133	PEG_RXN4
30	CLKRQ1	82	PEG_TXP13	134	PEG_TXN4
31	+12V	83	GND	135	PEG_RXP4
32	CLKRQ2	84	GND	136	PEG_TXP4
33	N/A	85	PEG_RXN12	137	GND
34	GND	86	PEG_TXN12	138	GND
35	PLTRST	87	PEG_RXP12	139	PEG_RXN3
36	SMBCLK	88	PEG_TXP12	140	PEG_TXN3
37	WAKE_N	89	GND	141	PEG_RXP3
38	SMBDATA	90	GND	142	PEG_TXP3

PIN	SIGNAL	PIN	SIGNAL	PIN	SIGNAL
39	GND	91	PEG RXN11	143	GND
40	GND	92	PEG TXN11	144	GND
41	PCIE RXN2	93	PEG RXP11	145	PEG RXN2
42	PCIE CKN2	94	PEG TXP11	146	PEG TXN2
43	PCIE RXP2	95	GND	147	PEG RXP2
44	PCIE CKP2	96	GND	148	PEG TXP2
45	GND	97	PEG RXN10	149	GND
46	GND	98	PEG TXN10	150	GND
47	PCIE RXP1	99	PEG RXP10	151	PEG RXN1
48	PCIE TXN2	100	PEG TXP10	152	PEG TXN1
49	PCIE RXN1	101	GND	153	PEG RXP1
50	PCIE TXP2	102	GND	154	PEG TXP1
51	GND	103	PEG RXN9	155	GND
52	GND	104	PEG TXN9	156	GND
				157	PEG RXN0
				158	PEG TXN0
				159	PEG RXP0
				160	PEG TXP0



Note: Daughter boards such as COM ports and low-profile PCIe extension boards can only be inserted to the mainboards with the same version. Failure to do so may damage the system. The board version is shown on top of the boards.

Reset Button (RST1)

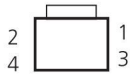

Pin NO.	Description
1	RST BTN
2	GND
3	GND
4	N/A

DC_IN CONNECTOR (CN4): A Phoenix connector for external power supply.



Pin No.	Pin Name
1	GND
2	DC_VIN

J1(PEG 16X lane Configuration): PCI/PCIe (PCIEIO1) expansion connector signal selection



Pin No.	Signal
1	GND
2	H_CFG5
3	GND
4	H_CFG6

Pin	Lane
All Off	x16
1-2 ON	x8, x8
3-4 Off (default)	Reserved
1-2 OFF	
3-4 ON	x8, x4, x4



Note: For PEG riser card, PEG lanes is reversed for layout limited

MPCIE1: Mini-PCIe Connector with SIM Card Reader

Pin	Signal	Pin	Signal
1	WAKE#	2	VCC3.3
3	N/A	4	GND
5	N/A	6	VCC1.5
7	CLKREQ#	8	USIM_PWR
9	GND	10	UIM_DATA
11	PCIE_CLK_N3	12	UIM_CLK
13	PCIE_CLK_P3	14	UIM_RESET
15	GND	16	UIM_VPP
17	RSV	18	GND
19	RSV	20	N/A
21	GND	22	PLTRST
23	PCIE_RX_N3	24	VCC3.3
25	PCIE_RX_P3	26	GND
27	GND	28	VCC1.5
29	GND	30	SMBCLK
31	PCIE_TX_N3	32	SMBDATA
33	PCIE_TX_P3	34	GND
35	GND	36	USB_N8
37	GND	38	USB_P8
39	VCC3.3	40	GND
41	VCC3.3	42	N/A
43	GND	44	N/A
45	RSV	46	N/A
47	RSV	48	VCC1.5
49	RSV	50	GND
51	RSV	52	VCC3.3

MPCIE2: Mini-PCIe Connector

Pin	Signal	Pin	Signal
1	WAKE#	2	VCC3.3
3	N/A	4	GND
5	N/A	6	VCC1.5
7	CLKREQ#	8	N/A
9	GND	10	N/A
11	PCIE_CLK_N4	12	N/A
13	PCIE_CLK_P4	14	N/A
15	GND	16	N/A
17	RSV	18	GND
19	RSV	20	N/A
21	GND	22	PLTRST
23	PCIE_RX_N4	24	VCC3.3
25	PCIE_RX_P4	26	GND
27	GND	28	VCC1.5
29	GND	30	SMBCLK
31	PCIE_TX_N4	32	SMBDATA
33	PCIE_TX_P4	34	GND
35	GND	36	USB_N9
37	GND	38	USB_P9
39	VCC3.3	40	GND
41	VCC3.3	42	N/A
43	GND	44	N/A
45	RSV	46	N/A
47	RSV	48	VCC1.5
49	RSV	50	GND
51	RSV	52	VCC3.3

Ignition Connector on board (ignition1): Power ignition connector.



Pin No.	Pin Name	Pin No.	Pin Name
1	DCIN_VCC	6	DC2DC_PWROK
2	DC_VIN	7	COM5_SIN
3	GND	8	SOUT
4	SYS_PWROK	9	PWR_BTN_IGN
5	DC2DC_EN	10	IGNITION

SATA_PW2: A switch for supply of SATA Connector II's power.

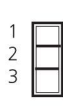

Pin No.	Pin Name
1-2	SATAII Connector without power
2-3	SATA II Connector with 5V power

CN3 (optional): An optional power connector with power-ignition Control



Pin No.	Pin Name
1	Ignition
2	GND
3	DC_VIN

DCJK1 (Optional): An optional DC Jack type of Power Connector

Pin No.	Pin Name
1	DC_VIN
2	GND
3	GND

LAN1/LAN2 Ports (LAN1/LAN2): The LAN ports are provided by Intel 82574L Ethernet controller whose interface complies with PCI-e 1.1 (2.5 Ghz). It has advanced management features including IPMI pass-through via SMBus or NC-SI, WOL, PXE remote boot, iSCSI boot and VLAN filtering.

Pin No.	Description	
	Fast Ethernet	Gigabit Ethernet
1	TX+	BI_DA+
2	TX-	BI_DA-
3	RX+	BI_DB+
4	--	BI_DC+
5	--	BI_DC-
6	RX-	BI_DB-
7	--	BI_DD+
8	--	BI_DD-

Enable or Disable Daughter Board LEK-IOA3 (COMSLT1): This jumper is for enabling or disabling the COM3, COM4 ports on daughter board LEK-IOA3.

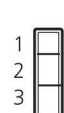

Pin No.	Pin Name
1-2	Disable
2-3	Enable

Enable or Disable Daughter Board LEK-IG1 (COMSLT2): This jumper is for enabling or disabling the COM5, COM6 ports on daughter board LEK-IG1.



Pin No.	Pin Name
1-2	Disable
2-3	Enable

Keyboard and Mouse Connector (KBM1)

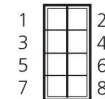

Pin No.	Pin Name	Pin No.	Pin Name
1	VCC5	2	MCLK
3	MDATA	4	NC
5	KDATA	6	NC
7	GND	8	KCLK

Chapter 4: Hardware Setup

Preparing the Hardware Installation

To access some components and perform certain service procedures, you must perform the following procedures first.



WARNING: To reduce the risk of personal injury, electric shock, or damage to the equipment, remove the power cord to remove power from the server. The power switch button does not completely shut off system power. Portions of the power supply and some internal circuitry remain active until power is removed.

1. Unpower the LPC8800-xxB2 and remove the power cord.
2. Unscrew the 4 threaded screws from the top cover.
3. Open the cover.



Note:

If the CPU thermal pad mounting breaks apart, use your hands to reattach the falling parts and stick them together.

Installing the System Memory

The motherboard supports DDR3 memory to meet the higher bandwidth requirements of the latest operating system and Internet applications. It comes with two Double Data Rate Three (DDR3) Small Outline Dual Inline Memory Module (SO-DIMM) socket.

1. Align the memory module's cutout with the SO-DIMM socket's notch.
2. Install the SO-DIMM.

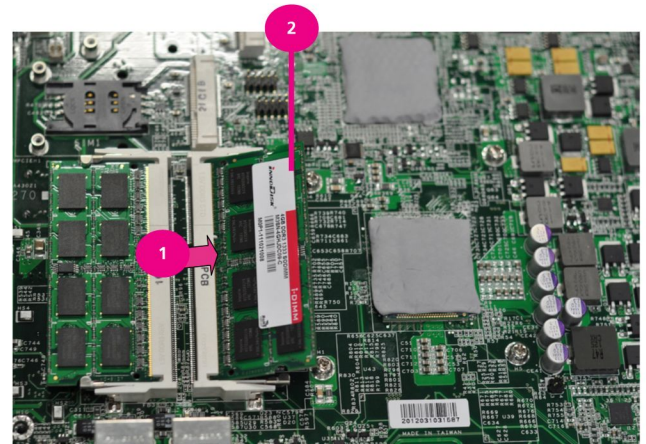

Note:

The system can support memory of DDR3 SO-DIMM up to 16 GB in maximum with 2 SO-DIMM sockets.

Wireless Module Installation

1. Align the wireless module's cutout with the Mini-PCIe slot notch.
2. Insert the wireless module into the connector diagonally.
3. Hold down the other end of the wireless module and tighten it with the screws.

3G SIM Card Installation

1. Unlink the SIM card reader first by sliding it outward.
2. Flip the SIM card reader diagonally.
3. Align the cut corner of the SIM card pointing toward SIM card reader. Make sure the ICs will be in contact with the SIM card reader.
4. Insert the SIM card into the reader and close the tray. You should feel a click when the SIM card is locked securely in the SIM card reader.

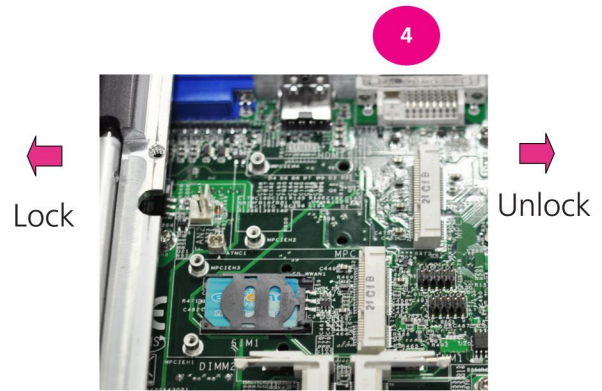
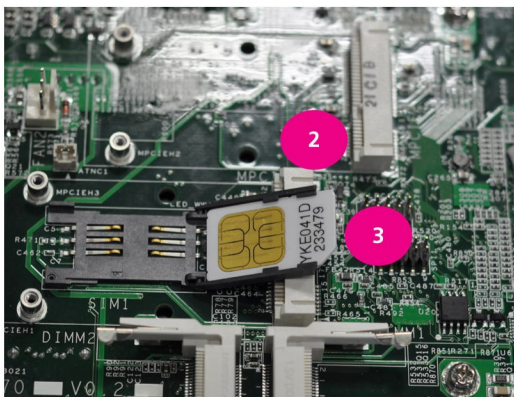
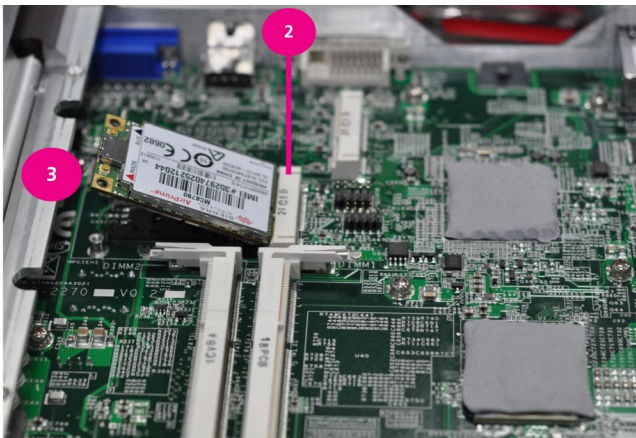

Note: To remove the SIM card, slide the card reader outward to unlock it.

PCI/PCIe Riser Card Installation

The system can accommodate one PCIe expansion (or two PCI expansion on model P2) module. In order to install the PCIe expansion module, a low-profile riser card has to be installed first. Follow these steps to install the riser card:

1. Fix the riser card on the bracket with 3 screws.
2. Install the riser card to the system by connecting the connectors with the system's PCIEIO1 connector.
3. Fix the riser card on the board.
4. Connect the PCIe expansion card to the riser.
5. Fix the card holder back to the system.

On LPC8800-xxB1 with one PCIe slot

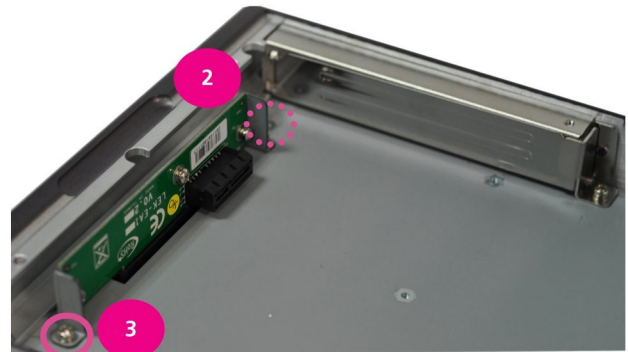

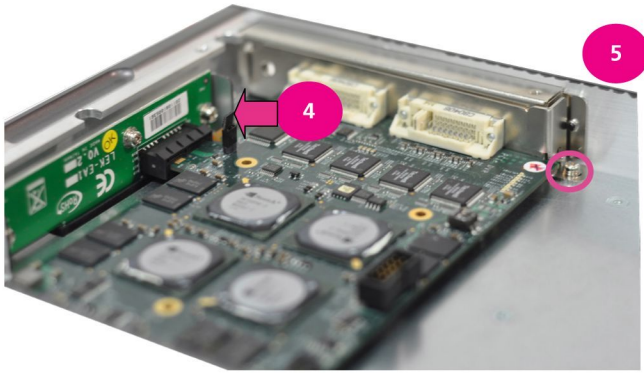

On LPC8800-xxB2 with 2 PCI slot

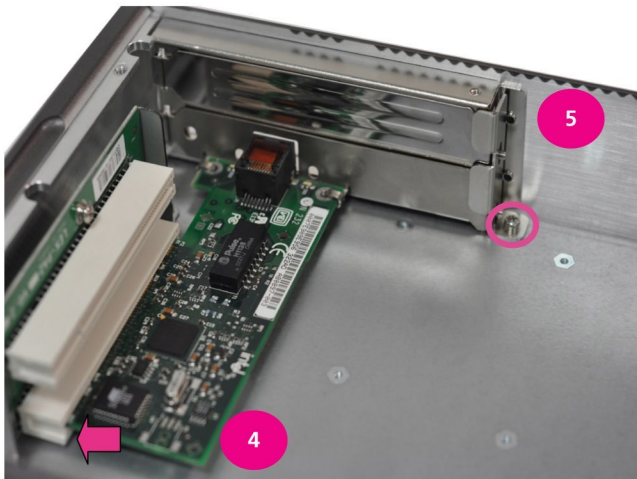

Note: Using a PCIe or PCI riser card, users have choice of either PCI Express x1 or PCI expansions.



1. 1 PCIe is supported on model LPC8800-xxB1
2. 2 PCI are supported on model LPC8800-xxB2
3. Both PCI or PCIe support the Max. Dimension as the following illustrated and the Max. Power consumption reserved for expansion is 25W in total.
4. Daughter boards such as COM ports and low-profile PCIe extension boards can only be inserted to the mainboards with the same version. The board version is shown on top of

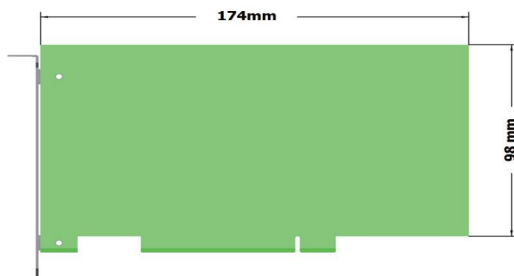

Installing the Hard Disk

The system can accommodate one Serial-ATA disk. Follow these steps to install a hard disk into the system:

1. Take out the hard disk tray and fix the hard disk on the tray with 4 mounting screws as illustrated in the following picture.
2. Plug the Serial-ATA cable to the hard disk.
3. Place the hard disk back to the system's chassis and fix it with the mounting screws.
4. Connect the Serial-ATA power and data disk cables to the Serial-ATA power and disk connectors on the main board respectively.

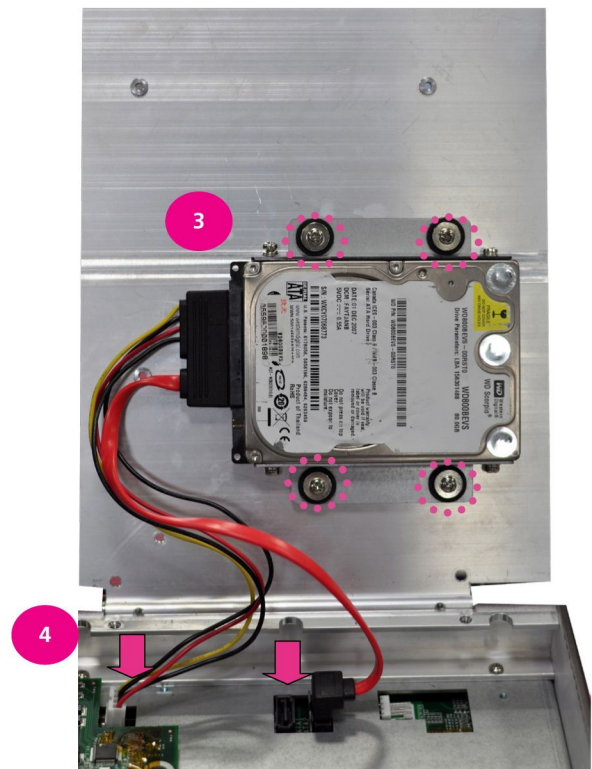

Connecting Power

Connect the LPC8800 to a +9~+30V DC-in power source. The DC power-in connector comes with a 2-pin terminal block for its Phoenix contact. This power socket can only accept the power supply with the right pin contact so be cautious when inserting power to the system.

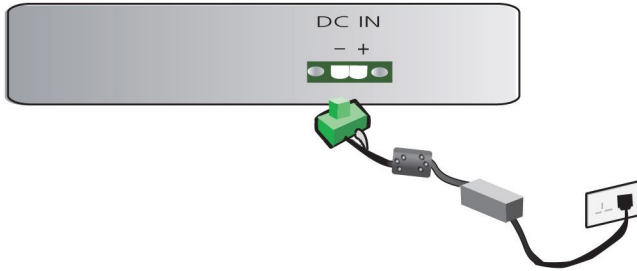

Wall Mounting

The product ships with wall mounting kit. To mount your product on the wall, follow the instructions below:

1. First make a hole for the anchor in the surface on the wall. Use the following diagram as a guideline for placing the anchors.
2. Then press the anchor into the hole until it is flush with the surface. You may need a hammer to tap the wall anchor.
3. Use a screwdriver to screw the threaded screw into the plastic anchor.
4. Attach the wall mounting bracket to the back of the device, securing it in place with four of the flat-head screws provided.
5. Hang the device on the wall.

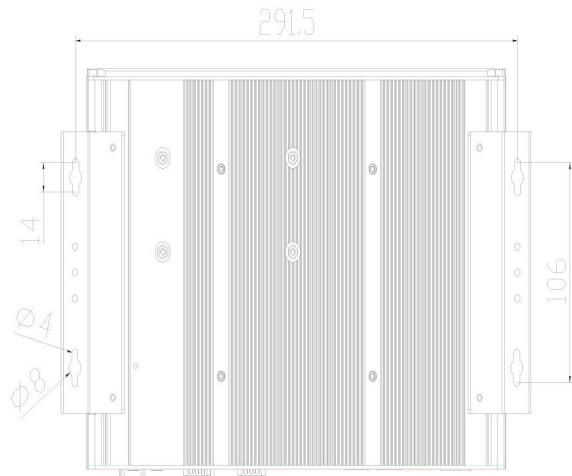

Unit: mm

Appendix A: Programming System Watchdog Timer

A watchdog timer is a piece of hardware that can be used to automatically detect system anomalies and reset the processor in case there are any problems. Generally speaking, a watchdog timer is based on a counter that counts down from an initial value to zero. The software selects the counter's initial value and periodically restarts it. Should the counter reach zero before the software restarts it, the software is presumed to be malfunctioning and the processor's reset signal is asserted. Thus, the processor will be restarted as if a human operator had cycled the power.

For sample watchdog code, see *watchdog* folder under LPC8800 Utility in the *Driver and Manual CD*



Executing through the Command Line:

Execute the WD.EXE file under DOS (WD.EXE and CWSDPMI.EXE should be placed in the same directory), then enter the values from 0~255. The system will reboot automatically according to the time-out you set.

Appendix B: Terms and Conditions

Warranty Policy

1. All products are under warranty against defects in materials and workmanship for a period of one year from the date of purchase.
2. The buyer will bear the return freight charges for goods returned for repair within the warranty period; whereas the manufacturer will bear the after service freight charges for goods returned to the user.
3. The buyer will pay for repair (for replaced components plus service time) and transportation charges (both ways) for items after the expiration of the warranty period.
4. If the RMA Service Request Form does not meet the stated requirement as listed on "RMA Service," RMA goods will be returned at customer's expense.
5. The following conditions are excluded from this warranty:

Improper or inadequate maintenance by the customer, unauthorized modification, misuse, or reversed engineering of the product Operation outside of the environmental specifications for the product.

RMA Service

Requesting a RMA#

1. To obtain a RMA number, simply fill out and fax the "RMA Request Form" to your supplier.
2. The customer is required to fill out the problem code as listed. If your problem is not among the codes listed, please write the symptom description in the remarks box.
3. Ship the defective unit(s) on freight prepaid terms. Use the original packing materials when possible.
4. Mark the RMA# clearly on the box.



Note: Customer is responsible for shipping damage resulting from inadequate/loose packing of the defective unit(s). All RMA# are valid for 30 days only; RMA goods received after the effective RMA# period will be rejected.

Appendix B

Terms and Conditions

RMA Service Request Form

When requesting RMA service, please fill out the following form. Without this form enclosed, your RMA cannot be processed.

RMA No:	Reasons to Return: <input type="checkbox"/> Repair(Please include failure details) <input type="checkbox"/> Testing Purpose
Company:	Contact Person:
Phone No.	Purchased Date:
Fax No.:	Applied Date:
Return Shipping Address: _____	
Shipping by: <input type="checkbox"/> Air Freight <input type="checkbox"/> Sea <input type="checkbox"/> Express _____	
<input type="checkbox"/> Others: _____	

Item	Model Name	Serial Number	Configuration

Item	Problem Code	Failure Status

*Problem Code:

- | | | | |
|------------------------|------------------------------|--------------------|--------------------------|
| 01: D.O.A. | 07: BIOS Problem | 13: SCSI | 19: DIO |
| 02: Second Time R.M.A. | 08: Keyboard Controller Fail | 14: LPT Port | 20: Buzzer |
| 03: CMOS Data Lost | 09: Cache RMA Problem | 15: PS2 | 21: Shut Down |
| 04: FDC Fail | 10: Memory Socket Bad | 16: LAN | 22: Panel Fail |
| 05: HDC Fail | 11: Hang Up Software | 17: COM Port | 23: CRT Fail |
| 06: Bad Slot | 12: Out Look Damage | 18: Watchdog Timer | 24: Others (Pls specify) |

Request Party

Confirmed By Supplier

Authorized Signature / Date

Authorized Signature / Date