

MasterConsole MX⁴

User's Manual

MX48

MX416

MX432



www.raritan.com

MasterConsole MX⁴

User's Manual

MX48
MX416
MX432

Copyright ©1999

Raritan Computer, Inc.

MX4-0C-E JUNE, 2001



Raritan Computer Inc.

400 Cottontail Lane
Somerset, NJ08873
USA

Tel: 1-732-764-8886

Fax: 1-732-764-8887

E-mail: sales@raritan.com

[Http://www.raritan.com](http://www.raritan.com)

Raritan Computer Europe, B.V.

Eglantierbaan 16
2908 LV Capelle aan den IJssel
The Netherlands

Tel: 31-10-284-4053

Fax: 31-10-284-4049

E-mail: sales.europe@raritan.com

[Http://www.raritan.com](http://www.raritan.com)

Raritan Computer Japan, Inc.

Kuga Building 7F, 11-6
Kuramae 4-chome Taitoo-Ku
Tokyo 111-0051, Japan

Tel: 81-3-5833-6360

Fax: 81-3-5833-6336

E-mail: sales.japan@raritan.com

[Http://www.raritan.co.jp](http://www.raritan.co.jp)

Raritan Computer Taiwan, Inc.

5F, 121, Lane 235, Pao-Chiao Rd.,
Hsin-Tien City, Taipei Hsien
Taiwan

Tel: 886-2-8919-1333

Fax: 886-2-8919-1338

E-mail: sales.asia@raritan.com

[Http://www.raritan.com.tw](http://www.raritan.com.tw)

FCC Information

This equipment has been tested and found to comply with the limits for a Class A digital device, pursuant to Part 15 of the FCC Rules. These limits are designed to provide reasonable protection against harmful interference in a commercial installation. This equipment generates, uses, and can radiate radio frequency energy and if not installed and used in accordance with the instructions, may cause harmful interference to radio communications. Operation of this equipment in a residential environment may cause harmful interference.

Product names mentioned in this document are trademarks or registered trademarks of their respective companies. MasterConsole MX⁴, MasterConsole II, MasterConsole, and their respective logos are registered trademarks of Raritan Computer, Inc. PS/2, RS/6000, and PC/AT are registered trademarks of International Business Machines Corporation. Mac is a registered trademark of Apple Computer Inc. Sun is a registered trademark of Sun Microsystems. Alpha is a registered trademark of Compaq Corporation. HP9000 is a registered trademark of Hewlett Packard. SGI is a registered trademark of Silicon Graphics, Inc.

Japanese Approvals

この装置は、情報処理装置等電波障害自主規制協議会（VCCI）の基準に基づくクラスA情報技術装置です。この装置を家庭環境で使用すると電波妨害を引き起こすことがあります。この場合には使用者が適切な対策を講ずるよう要求されることがあります。

Table of Contents

Chapter 1 Getting Started	1
Welcome	1
Introduction	1
Features	1
Quick Installation and Test	2
MX4 On-Screen User Interface	3
Chapter 2 Operating The MX ⁴	4
Logging In	4
Selecting a Computer	4
User Customization	7
On-Screen User Interface Functions	9
Chapter 3 Administrator Functions	10
Administration Menu	10
System Configuration	11
User Configuration	13
Channel Configuration	14
Set Second-Tier Names	15
Chapter 4 Installing MX ⁴	16
Installations	16
One-Tier Installation	16
Two-Tier Installation	18
Connecting Second-Tier MasterConsole(s) to the Base Unit	19
Connecting a MasterConsole MX ⁴ Unit for Second-Tier Operation:	19
Connecting a MasterConsole II C, X or S Unit for Second-Tier Operation	20
Connecting a MasterConsole P Model for Second-Tier Operation	21
Connecting Computers to Second-Tier MasterConsole(s)	21
Channel Configuration for Two-Tier Installation	21
Appendix A: Security Access And PublicView	24
Security Access Mode	24
PublicView Video Sharing Options	25
PublicView (P-View) Action	25
Appendix B: MX ⁴ Front Panel Controls	26
Front Panel Components and Functions	26
Start-Up Display	27
Normal Display	27
Function Selection Screen	28
Set LCD Contrast	28
Set Tier	29
Set Password	29
Disable Password	30
Logout	30
Select Sync Type	31
Reset MX ⁴	31
Display Serial Number (DSP Serial Number)	32

Display Firmware Version (DSP Firmware Vsn)	32
Appendix C: MCUpdate Program	33
Introduction	33
Installation	33
MCUpdate Operations	34
Attachments	37
Appendix D: OverView Program	39
Introducing Overview	39
Installation	39
OverView Operations	40
MC OverView FAQ'S	44
Appendix E: Glossary	45
Appendix F: Troubleshooting	48
Appendix G: Specifications	50
MX ⁴ Models	50
Cable Kits	50
Universal Cable Kits: For connecting computer to MX ⁴	50
Console Cable: For connecting MX ⁴ User Port to User Console	51
Cascading Cable: For connecting MX ⁴ to tier to another MX ⁴	51
Accessories	52
Appendix H: MX ⁴ Configurations	53
Basic: 4 Users and Up to 16 Computers	53
4 Users and Up to 64 Computers Matrix	54
MX ⁴ 4 Users and Up to 256 Computers Matrix	55

Table of Figures

Figure 1 OSUI Menu Structure	3
Figure 2 Log-In Menu	4
Figure 3 Selection Menu	5
Figure 4 Selection Menu By Name	5
Figure 5 PublicView Only Message	6
Figure 6 PublicView Sign On	7
Figure 7 PublicView Sing Off	7
Figure 8 User Profile Menu	7
Figure 9 Help Menu	9
Figure 10 Administration Menu	10
Figure 11 System Configuration Menu	11
Figure 12 PublicView Messages	12
Figure 13 Continuous Sync Configuration	12
Figure 14 User Configuration Menu	13
Figure 15 Channel Configuration Menu	14
Figure 16 One-Tier Configuration	16
Figure 17 One-Tier Installation Cabling Details	17
Figure 18 MX ⁴ Back Panel	17
Figure 19 K/B Mouse Adapters For PS/2 To AT	18
Figure 20 Two-Tier Configuration	19
Figure 21 Two-Tier Installation Cabling Details	21
Figure 22 Device Configuration Menu 1	22
Figure 23 Device Configuration Menu 2	23
Figure 24 Device Configuration Menu 3	23
Figure 25 MX ⁴ Front Panel	26
Figure 26 MX ⁴ Front Panel Buttons	26
Figure 27 LCD Normal Display	27
Figure 28 Function Selection	28
Figure 29 Set LCD Contrast	28
Figure 30 Set Tier	29
Figure 31 Set Front Panel Password	29
Figure 32 Disable Front Panel Password	30
Figure 33 Logout	30
Figure 34 Select Sync Type	31
Figure 35 Display Serial Number	32
Figure 36 Display Firmware Version	32
Figure 37 MX ⁴ Back Panel And Admin Port	33
Figure 38 Running MCUpdate Program	34
Figure 39 FILE Options Section	35
Figure 40 Communication Section	35
Figure 41 Update Commands Section	36
Figure 42 MX ⁴ Back Panel Showing RJ11 Admin Port	39
Figure 43 OverView Started	40
Figure 44 Communication Control Panel	40

Figure 45 Login To Database	41
Figure 46 Log Window	42
Figure 47 Edit User Profile	42
Figure 48 Edit Device Profile	43
Figure 49 MX ⁴ Basic Configuration	53
Figure 50 MX ⁴ 4X64 Configuration	54
Figure 51 MX ⁴ 4X256 Matrix Configuration	55

Chapter 1 Getting Started

Welcome

Congratulations on your purchase of Raritan Computer's MasterConsole [MX⁴](#).

Introduction

Raritan's keyboard/video/mouse (KVM) switches are engineered to provide reliable, cost-effective, central control of multiple computers. This eliminates the cost and clutter of unnecessary equipment, reclaims space, and improves productivity for a host of applications.

[MX⁴](#) is a matrix KVM switch that enables up to four simultaneous users to select and operate connected computers. Each user will have exclusive control of any selected computer. The [MX⁴](#) can be configured to allow sharing of videos among users.

Each user is provided with an on-screen user interface (OSUI) menu to facilitate operation. A LCD display on the [MX⁴](#) front panel continuously displays the status of the system, and front-panel control buttons enable the administrator to perform maintenance functions and define system operation parameters. The firmware control program can be upgraded via a built-in communication port.

Raritan's unique emulation technology dedicates a keyboard and mouse emulator for each computer to ensure that each computer always "sees" its own keyboard and mouse, ensuring flawless boot up and operation.

Features

- Offering models to connect 8, 16, or 32 computers with up to 4 user consoles
- Ability to cascade units to control up to 256 computers
- Locate computers, cascaded units, or user consoles (keyboard, monitor, mouse) up to 325 feet away from the [MX⁴](#) with or up to 1000 feet away using Cat5 Reach
- Easy to install tangle proof, double-shielded coaxial cable in lengths of 2, 6.5, 13, 20, and 30 feet
- Built in dedicated keyboard and mouse emulators for flawless operation
- Includes Keep-alive design to ensure non-stop computer operation in case of power loss to the switch
- Supports high-resolution video to 1600 x 1280
- Allows a mix PCs, Macs, Suns, Alphas, RS/6000s, HP9000s, USB and SGIs
- Contains a powerful on-screen user interface for simple operation and system management
- Assigns meaningful names to connected computers and select from pop-up, on-screen menus

- Stores up to 128 user names, each with personalized operating profile and optional password for security
- Contains individual user-controlled functions to AutoSkip inactive channels and to AutoScan computers at variable rates
- Engineered with multilevel security to ensure authorized access to each computer by each user
- Expand capabilities by cascading MX⁴ units using 1, 2, 3, or 4 ports—unused user ports available for local user consoles
- Offers PublicView video sharing features with several options for users to share video with follow along and camp-on actions
- OSUI supports French and German keyboard layouts
- Has a front panel LCD display status of user ports
- Available on-site firmware upgrades via built-in RJ11 administration port
- Is compatible with MasterConsole C Model, S Model, X Model, and P Model
- Add on optional 19” rack mount brackets
- OverView—an optional PC Windows feature—facilitates on-line, real-time monitoring, tracking, system administration, as well as reporting from an industry standard PC (see *Appendix D: OverView Program*)

Quick Installation and Test

Chapter 4 specifies a detailed installation procedure. For a quick installation and test of MX⁴, perform the following:

1. Plug the power cord into the MX⁴, and turn the power switch to ON.
2. Observe the LCD display on the front panel as the MX⁴ goes through a power-on self-test. When the LCD displays a circulating “**Raritan MX48: Base MX48**” message, the unit is ready.
3. Locate user console cable—CCPnnF. Plug the DB25 connector to a user port on the back panel of the MX⁴ unit.
4. Plug a user console-keyboard, monitor, and mouse-into the connectors at the other end of the user cable.
5. **Login Menu** will now be displayed on the monitor. The keyboard's <**Scroll Lock**> LED will be blinking.
6. Enter *usera* as user name, and press <**Enter**>. A **Selection Menu** will be displayed on the monitor.
7. Unwrap a universal cable—CCPnnU. Plug the DB25 connector into a channel on the back panel of the MX⁴ unit.
8. Plug the other end of the cable to a PC's keyboard/mouse/VGA ports.
9. Power on the PC.
10. The PC channel on the **Selection Menu** will turn green.

11. Use the keyboard <↑> and <↓> keys to select the green line, and press <Enter>.
12. You will now be able to operate the PC connected to MX⁴.

Congratulations! This quick test is complete.

- ☞ ¹To go back to the MX⁴ selection menu, press the <Scroll Lock> key twice rapidly. This activates the on-screen user interface. The <Scroll Lock> LED on the user console keyboard blinks, indicating the on-screen user interface has been activated.

MX⁴ On-Screen User Interface

The MX⁴ on-screen user interface (OSUI) consists of a simple hierarchy of menus and screens. Each menu (except Login Menu) contains the following sections (Figure 1):

- Title Line
- Menu/Screen Body (for text and fields)
- Help Messages
- Status Line (displays Skip/Scan status, OSUI activator, and P-View indicator if appropriate)

Function keys F1, F2, F4, and F5 switch between different first-level menus.

- ☞ Pressing <F1> while the on-screen user interface is active invokes the Help Screen, which details all options available to the user.
- ☞ Whenever the on-screen user interface is activated on a user console, that console keyboard's <Scroll Lock> LED indicator blinks.

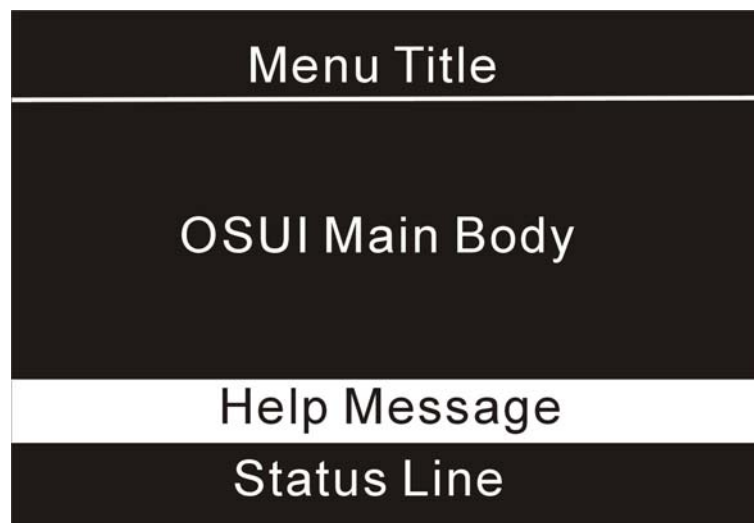

Figure 1 OSUI Menu Structure

¹ The symbol ☞ provides hints and tips.

Chapter 2 Operating The MX⁴

This section describes how a user operates MX⁴ functions to access computers.

Logging In

☞ You must first login to access the computers connected to the MX⁴.

When the system is first turned on, the **Log-in Menu** is displayed on the monitor of each user console. (Figure 2). Device ID is the name of this MX⁴ unit, and User Port is the number-1, 2, 3, or 4-of the physical MX⁴ user port to which this user console is currently connected.

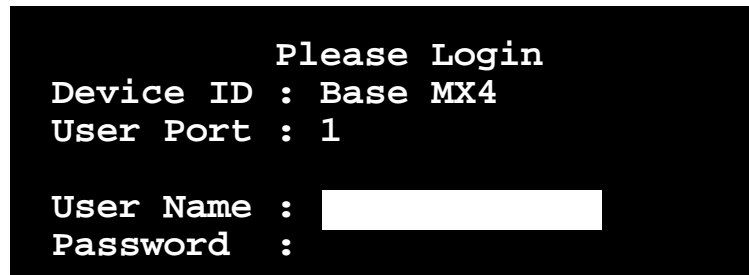

Help Messages

Figure 2 Log-in Menu

1. Enter your **user name** assigned by your administrator. If user names have not been assigned, the default is *usera*, *userb*, *userc*, or *userd* for users, and *admin* for the administrator. User names are not case sensitive.
2. Press **<Enter>**. If a password is necessary, you will be prompted to enter it, and press **<Enter>** again. **Passwords are case sensitive.** (See Changing Password on page 9.)
3. The **Selection Menu** will be displayed (Figure 3 & Figure 4.) To go to other menus, use the function keys. (See On-Screen User Interface Functions on page 9.)

Selecting a Computer

1. Activate the on-screen user interface by pressing the **<Scroll Lock>** twice rapidly. The **Selection Menu** will be displayed (See Figure 3 & Figure 4.)
2. The Selection Menu lists channels sorted either by channel ID (**Ch. ID**) number or alphabetically by computer name. Default sorting is by channel ID number. Press **<F12>** to toggle between sorting by channel ID number and by computer name.
 - The Selection Menu displays up to eight channels.
 - The Ch. ID column indicates the physical channel to which each computer is connected.
 - The Name column lists the computer name.

- The Stat column shows each channel's security class on the left side of the column, and the channel-specific scan rate—in seconds—on the right side of the column. (See Channel Configuration on page 15 for instructions for changing channels, security classes, and scan rates.)

Selection Menu			
MC: Base MX4		Page	1 / 1
Ch.ID	Name	Stat	
1 01	Untitled-001	A0	03
2 02	NT4.0-Mail	A0	03
3 03	Wins95.Bob	B0	03
4 04	▶ Wins98.Jack	A0	03
5 05	Untitled-005	A0	03
6 06	NT4.0-Susan	A0	03
7 07	Untitled-007	A0	03
8 08	Untitled-008	A0	03

Help Messages

Status Line

Figure 3 Selection Menu

Selection Menu by Name		
		Page 1 / 1
Name	Ch.ID	Stat
NT4.0-Mail	02	A0 03
NT4.0-Susan	06	A0 03
▶ Wins95.Bob	03	B0 03
Wins98.Jack	04	A0 03
Untitled-001	01	A0 03
Untitled-005	05	A0 03
Untitled-007	07	A0 03
Untitled-008	08	A0 03

Help Messages

Status Line

Figure 4 Selection Menu by Name

3. The highlight bar is used to select a channel for connection to the local user console. Each channel's availability is visually indicated by the following text colors:
 - Black—no computer connected or computer is powered down
 - Green—channel is active and available
 - Red—unavailable
 - Yellow—unavailable, another user is connected, but the video is available to view
 - Purple—connected to a MasterConsole II or MasterConsole P model
 - Cyan—connected to a second-tier MX⁴. The highlight bar skips this channel.
 - White—current status unknown
 - ☞ If the security class of a channel is shown in red, the channel cannot be selected due to security restrictions.
 - ☞ A small red triangle points to the name of the computer—if any—to which you are currently connected.
4. To select a computer:
 - Press the **<Page Up>**, **<Page Down>**, **<↑>**, and **<↓>** keys to highlight the desired computer and press **<Enter>**,
 - When the Selection Menu is sorted by channel ID number, press the desired computer's key number—shown in the left-hand column—and press **<Enter>**,
 - When the Selection Menu is sorted by Name—arranged alphabetically— you can type the first character(s) of the desired name to quickly jump to the name that most closely matches the characters you type, and press **<Enter>**.
5. When you select a computer, you automatically return to normal computer operation at the selected computer.
 - If you select a MasterConsole device, you'll go to the Selection Menu of that device. To return to the base MX⁴ Selection Menu from any other Selection Menu, press the **<Home>** key.
 - ☞ If you select another computer's video to share (PublicView option), a message is displayed as shown in Figure 5. Pressing the hot-key activator twice returns you to your previous menu.

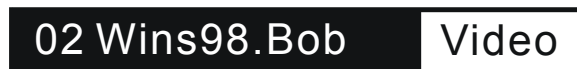

Figure 5 PublicView Only Message

- ☞ If another user selects your computer's video to view, a message is displayed as shown in Figure 6. The name of the previous user is attached. When a user selects to stop viewing your video, another message is displayed as shown in Figure 7. Pressing the hot-key activator twice clears these messages.

P-View Active - Jayson

Figure 6 PublicView Sign On

P-View Active - Jayson

Figure 7 PublicView Sign Off

User Customization

The **User Profile** screen is for displaying your **MX⁴** configuration and for setting / changing your preferred operating parameters (Figure 8).

1. Activate OSUI by pressing the **hot-key <Scroll Lock>** key twice rapidly.
2. Press **<F4>** to access the User Profile screen.
 - The **Connected** field displays the name and the channel ID number of the currently selected computer.
 - The **User** field displays the User Name entered at login.
 - The **Station** field displays the physical **MX⁴** user port you are connected to.
 - The **Security** field displays your security class.
 - The **Admin** field displays your administrator privileges.

```

User Profile
Connected: Wins95.Bob   Ch 3
User: Susan           Station: 1
Security: A0          Admin: Yes

Scan Mode: Global
Global Scan Rate: 03 Seconds
ID Display: On       03 Seconds
Green Mode: Off     05 Minutes
Hotkey:      Scroll Lock
Display Position: Menu ID
Help Mode: Circ Left
P-View Switch: Do Nothing

Help Messages

Status Line

```

Figure 8 User Profile Menu

3. Select the field you want to edit by pressing the **<Tab>** (forward) **<Shift-Tab>** (backward) keys to move to the desired field. Press **<Enter>** to begin the edit. The

highlighted area will turn green. When the editing is completed, either press **<Enter>** to retain the changes or press **<Esc>** to cancel them.

- **Scan Mode:** Use the **<↑>** and **<↓>** keys to toggle between **Global** and **Individual**. The **Global Scan Mode** scans each channel for the same amount of time, indicated by the **Global Scan Rate**. The **Individual Scan Mode** scans each channel for the specified time as shown in the Selection Menu. The default setting is Global. (Setting the channel's individual scan rate is an administrator function—see page 15.)
 - **Global Scan Rate:** Type a number from 01 to 24, or use the **<↑>** and **<↓>** keys to increment or decrement. The default setting is 3 seconds.
 - **ID Display:** The ID Display is a small window that shows the computer name and the channel ID number when you switch or scan between channels. It is controlled by two fields:
 - **On/Off:** Use the **<↑>** and **<↓>** keys to toggle on and off.
 - **Time:** Type a number from 01 to 24, or use the **<↑>** and **<↓>** keys to increment and decrement. When incremented beyond 24, it displays “—”, indicating that ID window will be shown all the time. The default setting is On/03 seconds.
 - **Green Mode:** The Green Mode (**PowerSave** mode) blanks the screen if the user console is idle for the specified amount of time. It is controlled by two fields:
 - **On/Off:** Use the **<↑>** and **<↓>** keys to toggle on and off.
 - **Time:** Type a number from 01 to 99 or use the **<↑>** and **<↓>** keys to increment and decrement. The default setting is On/05 minutes.
 - **Hot-key:** Use the **<↑>** and **<↓>** keys to select **<Scroll Lock>**, **<Caps Lock>**, or **<Num Lock>**. Press the selected hot-key twice rapidly to activate the on-screen user interface. The default setting is **<Scroll Lock>**.
 - **Display Position:** This lets you position the On-Screen menu and ID Display window. Use the **<↑>**, **<↓>**, **<←>** and **<→>** keys to position the selected window.
 - **Help Mode:** Use the **<↑>** and **<↓>** keys to select the preferred help mode. This controls how the help messages are presented on the on-screen user interface menus and screens. The default setting is Circulate Left.
 - **PublicView Action (P-View Action):** PublicView enables video sharing. The administrator can set the PublicView video sharing option to grant system-wide permission that allows the video of any user to be viewed by any other user. If the administrator permits video sharing, the option is used for setting user preferences. Use the **<↑>** and **<↓>** keys to select the preferred mode: “Do Nothing”, “Follow User”, “Connect PC”, or “Notify”. (See *Appendix A: Security Access and PublicView* on page 26 for detailed explanations.)
4. **Changing Password:** To add, delete, or change your password, press **<P>**. You will be prompted to enter your new password of up to eight characters. Press **<Enter>**, and confirm by re-entering your new password. Then either press **<Enter>** again to retain the change or press **<Esc>** to cancel it.
 5. **Saving Changes:** Press **<S>** to save your changes at any time. When you press **<S>** or exit the menu, you will be prompted to confirm your changes.

On-Screen User Interface Functions

Use the following function keys to access MX⁴ OSUI functions:

PRESS...	WHEN YOU WANT TO...
<F1>	access Help; get a list of all of the function keys (Figure 9)
<F2>	access Selection Menu; view the list of channels, security levels, or scan rates; or select a channel
<F4>	access the User Profile or view and change user-specific operating parameters
<F5>	access the Administration Menu if you have administrator privileges
<F6>	toggle On/Off AutoScan
<F7>	toggle On/Off AutoSkip
<F8>	permit/deny PublicView
<F9>	logout
<Shift-F9>	disconnect from a channel without logging out
<F12>	while in Selection Menu, toggle sorting by name or channel ID
<Esc>	Exit

- ☞ If a user does not have administrator privileges, then the F5 function is displayed in red.
- ☞ If F8 has no effect with respect to granting Public View permission based on the view-mode setting, it is displayed in red.

```

                                Help
    MX4 Version:      MX4-V2.28
    Serial Number:   CWA40035
    F1 Help    /   Esc Exit
    F2 Channel Selection
    -F12 Sort by Channel/Name
    F4 User Profile
    F5 Administrative Functions
    F6 Toggle Scan On/Off
    F7 Toggle Skip On/Off
    F8 Permit/Deny Public View
    F9 Logout/Login as new user
    -Shft+F9 Release Channel
  
```

Help Messages

Status Line

Figure 9 Help Menu

Chapter 3 Administrator Functions

This section describes the functions that enable the administrator to configure the MX⁴ system so the user can access the computers connected to the MX⁴. The functions are performed from a set of administration menus.

Administration Menu

The Administration Menu is used for setting security classes, maintaining user names and privileges, and managing the system configuration. These tools enable the administrator to control access to the MX⁴ and to all connected computer resources.

1. Log in to the system as *admin* or your user name, if you have administrator privileges. The Selection Menu will be displayed.
 - ☞ The default password for the login *admin* is “raritan” and is case sensitive. Press <F5> to access the Administration Menu. The Administration Menu displays user port connections (Figure 10).
 - **User Port Connections:** User names of the users logged in to each user port.
2. Use the <↑> and <↓> keys to select the desired submenu, and press <Enter>.

```
Administration Menu
User Port Connections
1: Susan          2: Jayson
3: None          4: None

Choose Admin Function
- -----
1 System Configuration
2 User Configuration
3 Channel Configuration
4 Set 2nd Tier Names
- -----

Help Messages
Status Line
```

Figure 10 Administration Menu

System Configuration

The System Configuration menu is used for setting the global parameters that control operation of the system for all users (Figure 11).

1. The System Configuration screen displays the current settings of the parameters.
2. To select the field you want to edit, press the **<Tab>** (forward) and **<Shift-Tab>** (backward) keys to move to a desired field. Press **<Enter>** to edit the field. The highlighted area will turn green. When the editing is completed, either press **<Enter>** to retain the changes or press **<Esc>** to cancel them.

```

System Configuration
Device ID: Base MX48
Security
  Timeout: On Logout 15 Min
  Access Mode: Free Access
  P-View Mode: User Permit
  Admin Silent P-View: Yes
  Allow Blank Password: No

KB Language Type: English
Login Blank: Off 05 Minutes
Login Help Mode: Multi-Line
Auto Sync Detection

Help Messages

Status Line

```

Figure 11 System Configuration Menu

- **Device ID:** This is the name of the MX⁴. Type in the desired name of the device. This gives the device a unique and meaningful name, which is important if you have multiple MasterConsole units. The default names are Base MX416 and Base MX48.
- **Time Out:** This is the amount of time—in minutes—before a user is logged out of the MX⁴ system or disconnected from a computer, if the user console is idle for that amount of time.
 - **On/Off:** Use the **<↑>** and **<↓>** keys to toggle On/Off.
 - **Logout/Disc.:** Use the **<↑>** and **<↓>** keys to toggle Logout/Disc.
 - **Time:** Type a number from 01 to 99, or use the **<↑>** and **<↓>** keys to increment or decrement the Time Out time in minutes. The default setting is On/5.

- **Access Mode:** Use the <↑> and <↓> keys to select one of the four Access Modes: Free Access, Exact Match, 2 Digit Level, and Level/Group. The default is Free Access. (See *Appendix A: Security Access and PublicView* on page 26 for detailed explanations of security modes.)
- ☞ The security classes for individual users and channels must be set in the User Configuration Menu and the Channel Configuration Menu of the administration menus.
- **P-View (PublicView) Mode:** Use the <↑> and <↓> keys to select “No V-share”, “Always On”, “Admin Only”, “User Permit”, “Admin or UP”. The default is “No V-share”. (See *Appendix A: Security Access and PublicView* on page 26 for detailed explanations of video sharing modes.)
- **Admin Silent P-View:** When video sharing is permitted, the user is notified if other user is sharing the video (Figure 12). If you have administrator privileges, this option allows you to turn off the message. Use the <↑> and <↓> keys to toggle Yes or No.

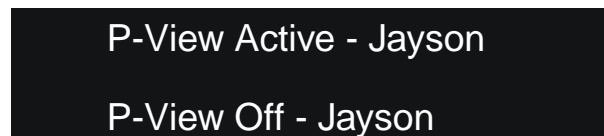

Figure 12 PublicView Messages

- **Allow Blank Password:** Use the <↑> and <↓> keys to toggle Yes or No. This field controls whether a user may specify a blank password. The default setting is No.
- ☞ If this field is set to No, a user may not set a blank password. A newly created user has by default no password unless the user or the administrator sets one.
- **KB Language Type:** The OSUI supports English, French, or German keyboard mapping. Use the <↑> and <↓> keys to select your keyboard type.
- **Login Blank:** The Login Blank feature blanks the Login screen after the user console is idle for the specified amount of time in minutes. This acts as a screen saver to protect the monitor. When this screen is blanked, press any key to bring back the Login screen. The fields are edited the same way as Security Time Out. The default setting is On/5 minutes.
- **Login Help Mode:** Use the <↑> and <↓> keys to select the desired help mode. This controls how the help and welcome messages are presented on the Login screen. The default setting is Multi-Line.

Figure 13 Continuous Sync Configuration

- **Ct Sync (continuous sync):** On *certain* MX⁴ units that do not have the automatic sync detection feature built-in, the System Configuration menu will have a option to allow you to manually set the sync type to accommodate certain types of monitors. See Figure 13. If you experience abnormality in the On-Screen Display, set the appropriate (or all) user port(s) to Y. The default is N. (See also Front Panel Function on page 32.)

User Configuration

The **User Configuration** Menu enables the administrator to add, delete, and edit user names and security rights (Figure 14). It also displays current connection status for each user.

User Configuration			
User: John		Page	1 / 1
Name	SC	Adm	Connection
Admin	A0	Yes	None
Jayson	A0	No	None
Usera	A0	No	None
Userb	A0	No	None
Userc	A0	No	None
Userd	A0	No	None
John	A0	Yes	Wins95.Bob

Help Messages

Status Line

Figure 14 User Configuration Menu

1. Use the <↑>, <↓>, <←>, <→>, <Tab>, <Shift-Tab>, <Page up>, <Page down>, <Home>, and <End> keys to move within the menu. Press <Enter> to edit the field. The highlighted area will turn green. When the editing is completed, either press <Enter> to retain the changes or press <Esc> to cancel them.
 2. This menu displays user information—one user per line.
 - **User:** This field displays your login user name.
 - **Name:** The Name column displays and allows editing of system user names. The user names are not case sensitive. Type up to 8 characters to change a name.
- ☞ The special user name **Admin** cannot be changed.

- **SC:** The SC column displays the security class of the user. Typing A-P changes the user's security level; typing 0-9 changes the user's security group. The default value of a newly created user is **A0**. (See *Appendix A: Security Access and PublicView* for details about security classes.)
 - **Adm:** The Adm column indicates whether the user has administrator privileges. Use the <↑> and <↓> keys to toggle Yes or No. The default setting is No.
 - **Connection:** The Connection column shows the status of each user and displays the channel to which any active user is currently connected.
3. **Adding a new user:** To add a new user, press <C>. A new default user name will be added. Proceed to edit the default name to the user name desired.
 4. **Deleting a user:** Move the highlight bar to a user line, and press <D>. The highlighted user will be removed from the system.
 5. **Logging out a user:** Move the highlight bar to a user line, and press <L>. The highlighted user will be logged out from the system.

Channel Configuration

The **Channel Configuration Menu** enables the administrator to edit the computer names, security classes, and individual scan rates associated with each channel (Figure 1). Any device—such as a computer or any MasterConsole unit—can be connected to **MX⁴** channels. To create a two-tier installation, MasterConsole units are cascaded from one or more of the **MX⁴** channels. (See Two-Tier Installation on page 19.) This section describes the channel configuration for a stand-alone **MX⁴**.

Channel Configuration Menu			
MC: Base	MX4	Page	1/ 1
Ch.ID	Name	Sec	Scn
01	Untitled-001	A0	03
02	NT4.0-Mail	A0	03
03	Wins95.Bob	B0	03
04	Wins98.Jack	A0	03
05	Untitled-005	A0	03
06	NT4.0-Yee	A0	03
07	Untitled-007	A0	03
08	Untitled-008	A0	03

Help Messages

Status Line

Figure 15 Channel Configuration Menu

1. Use the <↑>, <↓>, <←>, <→>, <Tab>, <Shift-Tab>, <Page up>, <Page down>, <Home>, and <End> keys to move within the menu.
2. Press <Enter> to edit the field. The highlighted area will turn green. When the editing is completed, either press <Enter> to retain the changes or press <Esc> to cancel them.

NOTE—Reserved Channel: If the channel shows **–RESERVED–** and you do not want this option set, *from within the **Channel Configuration** menu*, move the cursor to that channel and hit the B key. This will unblock the channel.

You can block a channel's access by going to that channel and hitting the B key. This function will eliminate the access by any user to that channel.

3. This menu displays channel information—one computer per line.
 - **MC:** This is the name of this MX⁴—same as MX⁴ ID.
 - **Ch. ID:** This column displays the physical Channel ID number to which the device connects to MX⁴.
 - **Name:** This column displays and allows editing of the computer name. Computer names are case sensitive and may be up to 12 characters.
 - **Sec:** This column displays the security class of the computer. Typing A-P changes the computer's security level; typing 0-9 changes the computer's security group. The default value of a computer is A0. (See *Appendix A: Security Access and PublicView* for detailed explanations of security modes.)
 - **Scn:** This column displays the computer's individual scan rate. Type a number from 01 to 24, or use the <↑> and <↓> keys to increment or decrement the scan rate. The default setting is 3 seconds.

Set Second-Tier Names

This selection enables you to change the name displayed on the LCD of the second-tier MX⁴ units. When this option is selected, the base MX⁴ will communicate with all second-tier MX⁴ units and update their names. A confirmation message—Names set on tiered units—will appear. (To set second tier names see [Channel Configuration for Two-Tier Installation](#) page 23.)

If no tier names have been entered, all tiered units LCD's will continue to display the MX⁴ default tier name.

Chapter 4 Installing MX⁴

Installations

MasterConsole MX⁴ can be installed to control 8, 16, or 32 computers in a one-tier installation with 4 simultaneous users. To expand computer capacity, the MX⁴ can be cascaded with other MasterConsole units to create a two-tier installation that controls up to 256 computers.

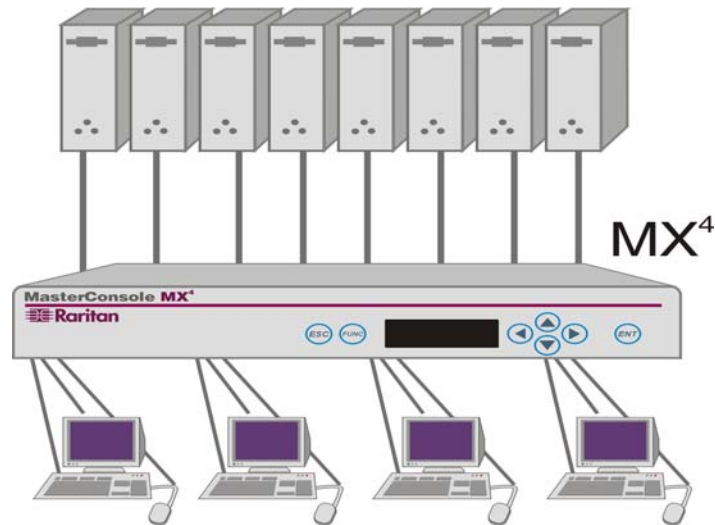

Figure 16 One-Tier Configuration

One-Tier Installation

In a one-tier installation, only computers are connected to a single MX⁴ unit (Figure 16). Complete the following steps for a one-tier installation:

1. Shut down and power off all computers to be connected to the MX⁴.
2. Install a user console to the MX⁴.
 - Plug the 25-pin connector of a user console cable (CCPnnF) into one of the four user ports on the MX⁴ back panel (Figure 17 and Figure 18).
 - Plug a user console (keyboard, monitor, and mouse) into the connectors at the other end of the user cable.
3. Power on the MX⁴ unit.
 - The MX⁴ will go through the start-up test. (See Start-Up Display on page 28.)
 - The Login Menu will be displayed on the monitor.
 - Enter *usera* in the user name field of the Login Menu, and press **<Enter>**. The Selection Menu will be displayed. (See page 5.)

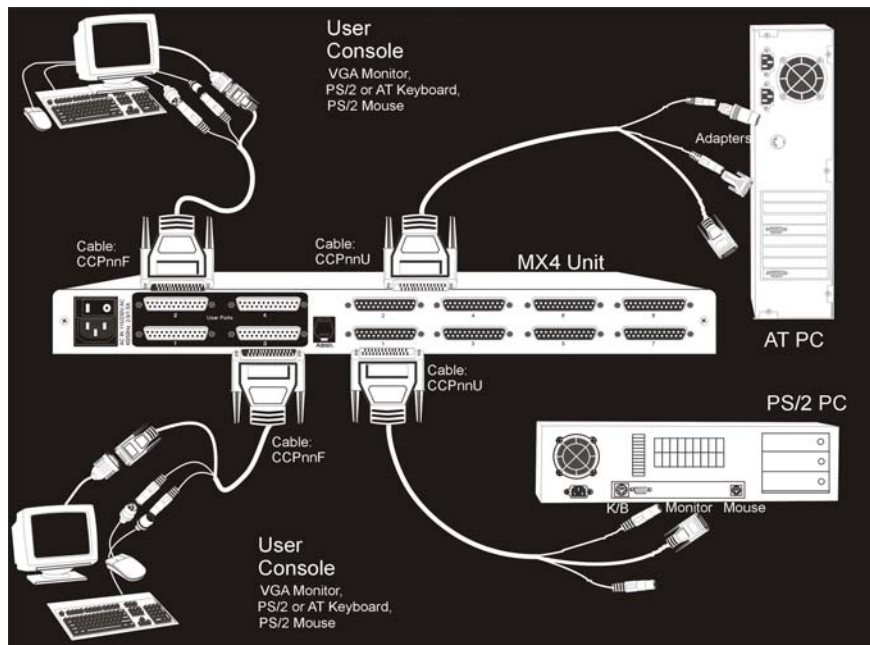

Figure 17 One-Tier Installation Cabling Details

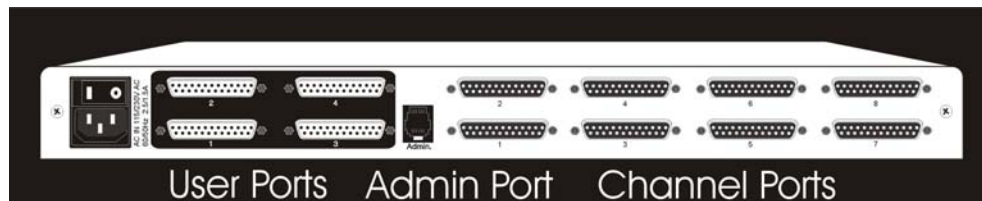

Figure 18 MX⁴ Back Panel

4. Connecting a computer to the MX⁴
 - Using a Universal Cable Kit (CCPnnU), plug the 25-pin connector into one of the numbered channels on the MX⁴ back panel.
 - Plug the cable's other connectors into the computer's keyboard, monitor, and mouse ports. Use supplied adapters for AT-style computers if needed (Figure 17 and Figure 19).
 - Power on the connected computer.
 - On the Selection Menu, the line displaying the channel to which the new computer has been connected will turn green.
 - Use the <↑> and <↓> keys to select the channel, and press <Enter>.
 - You will now be able to operate the computer just as if the keyboard, monitor, and mouse were connected directly.
5. Repeat steps 2 and 4 to connect the remaining user consoles and computers to the MX⁴.

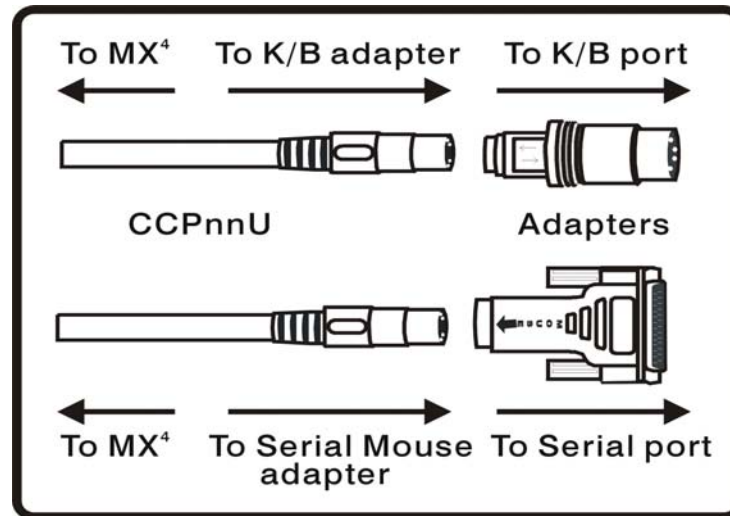

Figure 19 K/B Mouse Adapters for PS/2 to AT

Two-Tier Installation

In a two-tier installation, it is assumed that the base or first-tier unit is a MasterConsole **MX⁴**. Any device such as a computer or MasterConsole unit—second-tier unit—can be connected to any **MX⁴** channel.

Only computers may be connected to the channels of a second-tier MasterConsole (Figure 20 and Figure 21).

Install Base Unit—First-Tier—MasterConsole **MX⁴**

1. Follow the One-Tier installation procedure to set up the base **MX⁴** with the following exceptions:
 - Reserve one channel for each MasterConsole model II S, II X, and P unit, which you wish to cascade as a second-tier unit.
 - Reserve 1–4 consecutive channels for each **MX⁴** unit, which will be cascaded as a second-tier unit. A second-tier **MX⁴** can have 1, 2, 3, or 4 paths from the base **MX⁴**.
 - Power off the base **MX⁴** unit, and begin the procedure to connect second-tier MasterConsole(s) to the base unit (described below).
- ☞ If computers have already been connected to the base **MX⁴** unit, you do not have to shut down the computers; even when powered off, the **MX⁴**'s keyboard/mouse keep-alive feature continues performing keyboard/mouse emulation on attached computers.

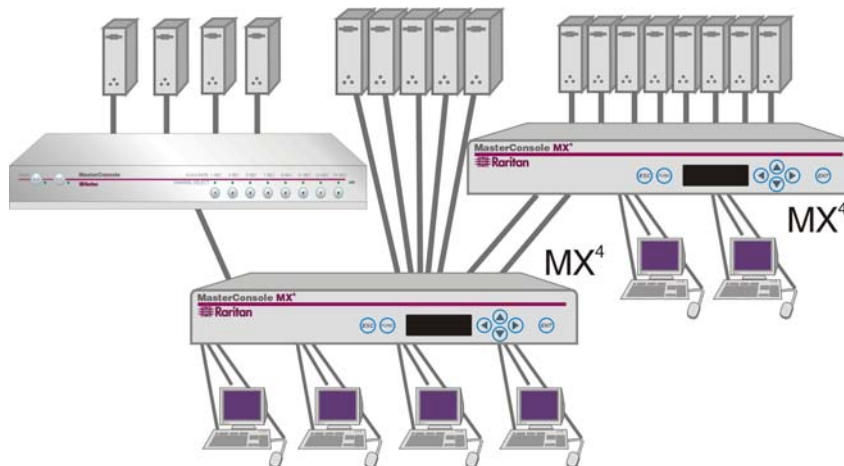

Figure 20 Two-Tier Configuration

Connecting Second-Tier MasterConsole(s) to the Base Unit

Power off all MasterConsole units before connecting them to the base MX^4 . Depending on the model, select one of the following procedures to install a second-tier MasterConsole. Then perform the appropriate channel configuration from the Administration Menu described in the next section. It is recommended that channel configuration be performed incrementally after each second-tier installation.

Connecting a MasterConsole MX^4 Unit for Second-Tier Operation:

1. Using a cascading cable (CCPnnE), plug the DB25 connector (female) into one of the 4 user ports of the second-tier MX^4 .
 2. Plug the cable's other DB25 connector (male) into the first of up to 4 consecutive channels reserved on the base MX^4 unit.
 3. Repeat steps 1 and 2 to connect the remaining user ports to the channels reserved on the base MX^4 .
 4. Power on the second-tier MX^4 .
 5. From the front panel, follow the Set Tier procedure (page 30) to set those user ports to second-tier status as indicated by the T on the front panel LCD display.
 6. Power on the base MX^4 units, and perform channel configuration from the Administration Menu, described in Channel Configuration for Two-Tier Installation (page 23).
- ☞ To guarantee correct operation, always power on the second-tier MX^4 before the base unit.

Connecting a MasterConsole II C, X or S Unit for Second-Tier Operation

1. To program the MasterConsole II unit as a second tier, while powering on, presses the Channel #2 button on the front panel and hold for 3 seconds. This sets the local user port of the MasterConsole II unit to second-tier status. For X models, you may use the user port out for the second-tier connection instead—by pressing and holding the Channel #3 button.
2. When the MasterConsole II unit is programmed as a second tier, the LED on the far right of the unit's front panel (RMT/2ND for X models and 2ND for C and S models) will be lit continuously.
3. Power off the unit.

Using a CCPnnU cable, plug the keyboard, monitor, and mouse connectors of the cable to the keyboard, monitor, and mouse ports on the second-tier MasterConsole II. —OR—

If you choose to use the user port of a MasterConsole II X model for second-tier connection, connect an RKVM module to the X model with a CVnn cable. Using a CCPnnU cable, plug the keyboard, monitor, and mouse connectors of the cable to the keyboard, monitor, and mouse ports of the RKVM module.

4. Plug the DB25 connector (male) on the other end of the CCPnnU cable into the channel reserved on the back panel of the base MX⁴.
5. Power on both the base MX⁴ and the second-tier MasterConsole II units, and perform channel configuration with the Administration Menu described in Channel Configuration for Two-Tier Installation (page 23).

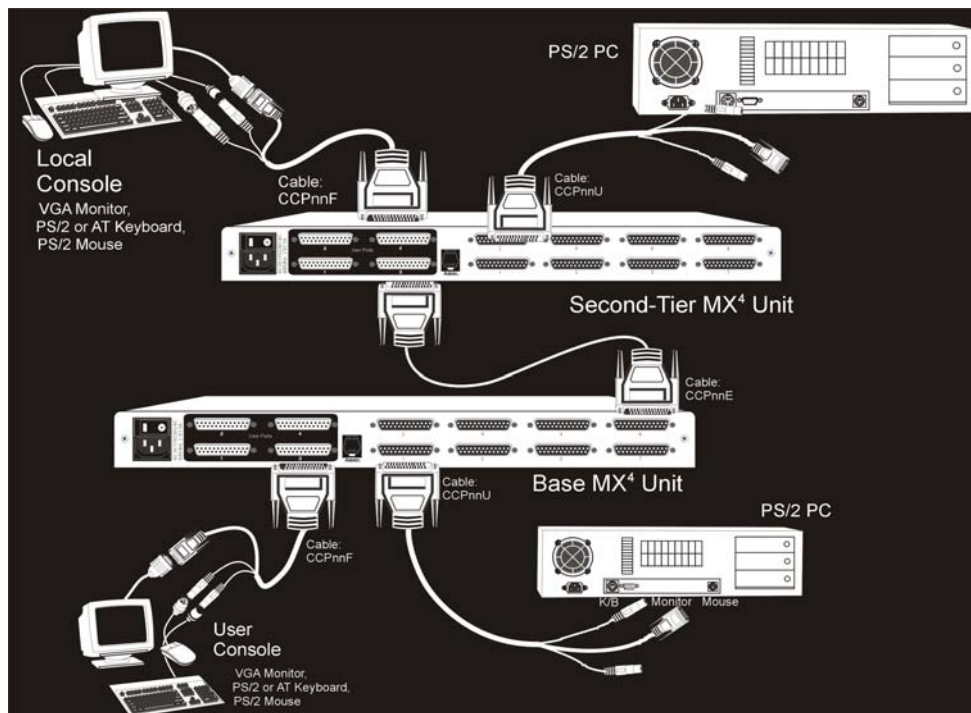

Figure 21 Two-Tier Installation Cabling Details

Connecting a MasterConsole P Model for Second-Tier Operation

1. Using a CCPnnU cable, plug the keyboard, monitor, and mouse connectors of the cable into the keyboard, monitor, and mouse ports of the second-tier MasterConsole P unit.
 2. Plug the DB25 connector (male) on the other end of the CCPnnU cable into the channel reserved on the base MX⁴ back panel.
 3. Power on both the base MX⁴ and the second-tier MasterConsole P units, and perform channel configuration with the Administration Menu described in Channel Configuration for Two-Tier Configuration (page 23).
- ☞ All second-tier MasterConsole P models must be MasterView ready. To determine whether your P model is MasterView ready, check the white label on the bottom of the unit. Locate the unit's firmware version: MDSP-*nnn*. If the firmware version is MDSP-1AC or higher (e.g., MDSP-1AD.), the unit is MasterView ready.
 - ☞ If your MasterConsole P model is rack mounted, call Raritan Technical Support with the unit's serial number located on the back of the unit.
 - ☞ MasterConsole P models that are not MasterView ready must be upgraded before they can be connected in second-tier configurations with MX⁴ units. Call Raritan Technical Support for details.

Connecting Computers to Second-Tier MasterConsole(s)

1. For a MasterConsole II C model, S model or X model follow the regular installation instructions detailed in your MasterConsole II manual.
2. For a MasterConsole P model follow the normal installation instructions detailed in your MasterConsole P Model manual.
3. For an MX⁴ model follow step 4 of MX⁴ One-Tier Installation detailed in the (page 17).

Channel Configuration for Two-Tier Installation

After installing a second-tier MasterConsole to a base MX⁴, you must perform channel configuration from the Administration Menu to reconfigure the base MX⁴. As explained in the Administration Menu section of this manual (page 11), you must login with administration privileges to access the administrator functions described here.

1. Press F5 to access the Administration Menu.
 2. Select the Channel Configuration submenu, and press **<Enter>**. The Channel Configuration menu will be displayed listing channel ID and channel names (Figure 15).
 3. Use the **<↑>** and **<↓>** keys to highlight the channel you reserved for the second-tier MasterConsole during the base MX⁴ installation process.
- ☞ Up to 4 consecutive paths or channels can be connected to a second-tier MX⁴ device. When a channel is selected for a second-tier MX⁴, up to 4 paths are available for selection. If any of the MasterConsole devices, MX⁴, MCP, MCC, MCS, or MCX, is

on any one of the 3 subsequent channels, it will limit the number of paths to be connected to base MX⁴.

4. Press **<C>** to display the Device Configuration screen (Figure 22).
 5. From the list of devices, select the appropriate device and press **<Enter>**. A next level of the Device Configuration menu will be displayed (Figure 23).
- ☞ **For MasterConsole II MCC models select line 2, “MasterConsole MXII-X”.**
6. From the list of device sizes, select the appropriate size and press **<Enter>**.
 7. If an MX⁴ is being configured as a second tier, an additional menu is displayed to allow you to specify the number of paths to connect to base MX⁴ (Figure 24). From the list of paths available, select the number of paths desired and press **<Enter>**.
 8. The display will return to the Channel Configuration menu (Figure 15).
 9. Press **<F2>** and confirm that the new MasterConsole device is displayed in purple on the proper channel in the Selection Menu (Figure 3).
 10. Select the new MasterConsole device, and press **<Enter>**.

```

      Device Configuration
Name: Untitled-001 Type:  PC
Connections: 1 Channels: --
Base: Base MX48      Ch.ID: 01
      Device                Abv
-  -----
1  MasterConsole MX4      MX4
2  MasterConsole MCII-X   MCX
3  MasterConsole MCII-S   MCS
4  MasterConsole          MCP
▶ 5  PC/No Device         PC
-  -----
▶ - Current Device Settings
      Help Messages
      Status Line

```

Figure 22 Device Configuration Menu 1

11. The Selection Menu of the new second-tier device will be displayed.

You can edit the second-tier unit name by going back to the Administration Menu and selecting Channel Configuration option and editing the tier names. On MX⁴ units, the tier name can be displayed on the LCD by selecting option 4 on the Administration Menu—Set 2nd Tier Names
12. You have now configured a *second-tier device* on to a base MX⁴.

Go back to the Channel Configuration Menu to name your *second tier device computers* by pressing **F5**. (Figure 15)

13. Select option number 3—Channel Configuration.
14. Using the <↑> and <↓> keys, highlight the *second tier device* you want to edit.
15. Press the **G** key—on the keyboard—to select this device for channel editing.
16. Edit the name(s) of the computers on the second tier.
17. Enter S to save edit or <esc> to cancel it.
18. Enter Y to save menu or N to re-edit.

```

      Device Configuration
Name: Untitled-001 Type:  PC
Connections: 1 Channels: --
Base: Base MX48      Ch.ID: 01
      Number of Device Channels
-  -----
  1   8 Channels
▶ 2  16 Channels
-  -----
▶ - Current Device Settings
      Help Messages
      Status Line

```

Figure 23 Device Configuration Menu 2

```

      Device Configuration
Name: Untitled-001 Type:  PC
Connections: 1 Channels: --
Base: Base MX48      Ch.ID: 01
      Number of User Connections
-  -----
▶ 1   1 Path
  2   2 Paths
  3   3 Paths
  4   4 Paths
-  -----
▶ - Current Device Settings
      Help Messages
      Status Line

```

Figure 24 Device Configuration Menu 3

Appendix A: Security Access and PublicView

Security Access Mode

The MX⁴ provides administrators with four modes of security access in addition to the login security. Depending on your business and security needs, choose the option best suited to manage your system.

- ☞ Users with admin privileges are always able to access any computers regardless of the mode.
1. **Free Access:** All users have free access to all channels. The only security is the login user name and password—if used. Setting security classes has no effect when this mode is invoked. Free Access is the default setting.
 2. **Exact Match:** The user's security class must be exactly the same as the channel security class in order for the user to access that channel.
 - Example: If both the user class and a channel class are B1, then the user can access that channel; if the user class is any other security class, access will not be allowed in Exact Match security mode.
 3. **2 Digit Level:** The user security class must be higher or equal to the channel security class in order to gain access. **A0 is highest; P9 is lowest.**
 - Example: A user of security class C2 can access all channels with a security class of C2 or lower, but cannot access any channels of security class C1 or higher.
 4. **Level/Group:** Access to a channel is determined by the following rules:
 - A0 is highest; P9 is lowest.**
 - If the letter level (1st position) of the user is higher than the letter level of the channel (1st position), access is allowed; if the level of the user is lower than the level of the channel, access is denied.
 - If the letter levels are equal, then the group (2nd position)—a number—determines access
 - Group 0 (zero) is the universal group: if either the user group or the channel group is 0, access is allowed.
 - Otherwise, the channel group number (2nd position) must match the user group number (2nd position) in order to gain access.

PublicView Video Sharing Options

Users of the MX⁴ have exclusive control of the computer selected. However, depending on your business needs, the administrator can configure the MX⁴ PublicView feature to allow users to view video of a computer controlled by another user. There are 5 PublicView options:

1. **No PublicView:** No video sharing—system default.
2. **Always On:** All users are permitted to view the video of computers being used by other users.
3. **Admin Only:** Only users with administrator privileges are permitted to view the video of computers being used by other users.
4. **User Permit:** User is permitted to view the video of another computer if the user currently in control of that computer has granted permission to do so.
5. **Admin or UP (User Permit):** This is a combination of options 3 and 4.

PublicView (P-View) Action

When a user is viewing the video of a connected user, there are four optional actions that can be executed when the connected user switches. The viewing user selects the action from the User Profile Menu. The actions are:

- **Do Nothing:** Continue viewing the video of the same computer.
- **Follow User:** Follow the connected user and continue viewing the video of the newly selected computer.
- **Connect PC:** Take control—become the connected user—of the computer that the original connected user has switched away from—unless access is denied due to specific user security.
- **Notify:** Do nothing but display a message when the connected user has switched away.

Appendix B: MX⁴ Front Panel Controls

The front panel of the MX⁴ consists of an LCD and 7 buttons (Figure 25 and Figure 26). The front panel controls provide special systems management and technical support functions. Normally there is no need to use the front panel beyond viewing status. Typically, the front panel is used for the following tasks:

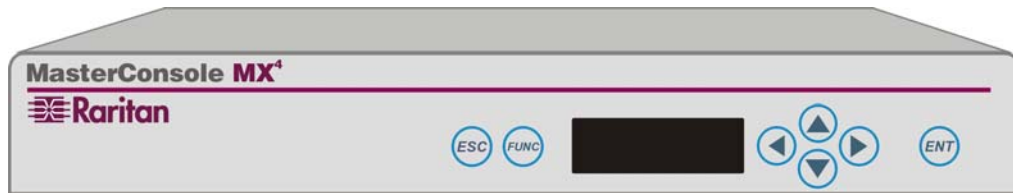

Figure 25 MX⁴ Front Panel

1. Confirming power on
2. Programming an MX⁴ unit for second-tier operation
3. Changing video-sync signal type for certain monitors

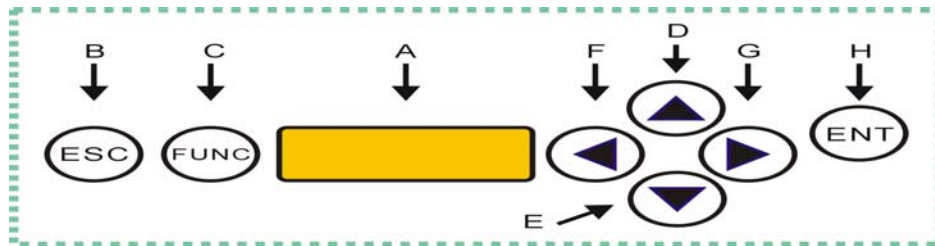

Figure 26 MX⁴ Front Panel Buttons

Front Panel Components and Functions

- The **LCD (A)** shows the status of the system and indicates the functions that can be selected by pressing the front panel control buttons.
- The **ESC button (B)** is used for canceling the displayed function and returning the system to the normal state.
- The **FUNC button (C)** is used to select the various functions.
- The **↑, ↓, ← and → buttons (D), (E), (F) and (G)** are used for selecting or setting various options depending on the function being performed.
- The **ENT button (H)** is used for confirming and executing the selected function.

Start-Up Display

When the **MX⁴** is turned on, it performs a start-up test. It checks each channel and user port to detect connections. If an error is detected, it displays “ERROR!” and stops the process.

- Press **ENT** to continue checking the remaining channels and ports.
- Recycle the power by turning the **MX⁴** off and on to clear the error conditions.
- If error persists, power down all computers and devices and then recycle the power again.
- If error condition still persists, contact Raritan Technical Support for further assistance.

Normal Display

After the start-up test, the LCD panel displays 2 circulating messages:

- Top line: “RARITAN <Model>: <Unit Name>”

Where, Model=“MX48”, “MX416”, or “MX432”, and Unit Name is the device name of the unit. The default unit names are “Base MX48”, “Base MX416”, or “Base MX432”. The base unit device name can be changed using the System Configuration option of the administration menu. The second tier device name can be changed using the Channel Configuration option and the Set 2nd Tier Names option of the administration menu. Please refer to those sections for details.

- Second line: user port status (Figure 27). The user port status line displays a scrolling status of all 4-user ports, one user port per second. The user’s active channel, Ch #, is displayed after the user port number. The first 3 positions of the display denote the Scan/Skip/Tier status—S, K, or T—or a *dot* if these options are not active.
 - First position: S—the user port is in **AutoScan** mode.
 - Second character: K—the user port is in **AutoSkip** mode.
 - Third character: T—the user port is configured to connect to another **MX⁴**—tier.
 - A *dot* appearing in any of these 3 positions indicates the option is not activated.



Figure 27 LCD Normal Display

Function Selection Screen

Seven functions can be performed from the front panel control: Set LCD Contrast, Set Tier, Set Password, Disable Password, Logout, Select Sync Type, and Reset [MX⁴](#). The following sections describe those functions.



Figure 28 Function Selection

Function Selection:

1. Press **FUNC** to enter the Function selection mode (Figure 28).
2. Use the **↑** or **↓** buttons to scroll through the Function List.
3. Press **ENT** to select the displayed function. Follow the sections below to perform the individual selected function.
4. Press **ESC** at any time to return to the Normal Display.

Set LCD Contrast

The Set LCD Contrast function modifies the contrast level of the front panel LCD display. (See Figure 29.)

To modify the LCD contrast:

1. Press the **↑** and **↓** buttons to increase and decrease the contrast.
 2. Press **ESC** to return to the normal display.
- ☞ The LCD contrast can also be adjusted by holding **←** button and pressing the **↑** or the **↓** buttons anytime during normal display.

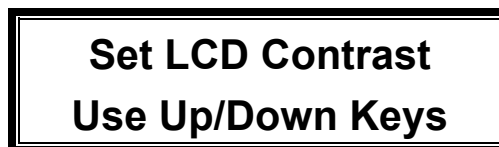

Figure 29 Set LCD Contrast

Set Tier

The Set Tier function should be used only on second-tier **MX⁴** units. Be sure to carefully review Two-Tier Installation on page 19 before proceeding with the Set Tier function (Figure 30).



Figure 30 Set Tier

The Set Tier function programs the user ports of a second-tier **MX⁴** to properly perform as a second-tier device. Each of the 4 user ports on a second-tier **MX⁴** unit must be programmed as follows. **Perform steps 1-3 of Function Selection first.**

To set a second-tier user port to connect to a Base **MX⁴**:

1. Press the **↑** or **↓** buttons to select the user port number you wish set to second-tier status.
2. Press the **←** button to toggle the tier indicator—denoted by “T”—on and off.
3. Press **ENT** to confirm the selected settings, or,
4. Press **ESC** to return to the Normal Display and retain the previous setting.

Set Password

The Set Password function enables the administrator to password protect access to front panel functions (Figure 31). A valid front panel password consists of a sequence of exactly six button presses, which must be repeated exactly to gain access. **Perform steps 1-3 of Function Selection first.**



Figure 31 Set Front Panel Password

To set the password for the front panel:

1. When prompted, enter a sequence of any 6 front panel button presses except **ESC**. The second line of the LCD display will show an asterisk (*) for each button pressed.
- ☞ Pressing **ESC** before finishing the 6 button presses exits this function without setting a front panel password.

2. The LCD display will prompt you to enter the button sequence a second time for confirmation. Entering the new 6-button password confirms it.
 3. Press **ESC** to return to the Normal Display.
- ☞ If the front panel is password protected, you must enter your password to access any of the front panel functions.

Disable Password

The Disable Password function disables the front panel password and allows unrestricted access to front panel functions (Figure 32). **Perform steps 1-3 of Function Selection first.**

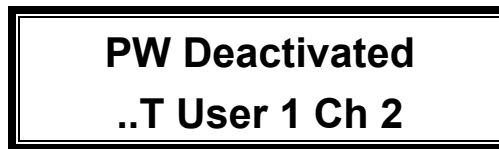

Figure 32 Disable Front Panel Password

1. When this function is selected, the LCD confirms that the password has been deactivated.
2. Press **ESC** to return to the Normal Display.

Logout

If a front panel password has been established, the Logout function exits the current front panel operation and returns to password protected (Figure 33). A password is needed to gain control of the front panel functions. **Perform steps 1-3 of Function Selection first.**



Figure 33 Logout

1. When this function is selected, the LCD display confirms the logout by showing "Bye Now!" on the second line.
2. Press **ESC** to return to the Normal Display.

Select Sync Type

This function is disabled on models with Automatic Sync Setting feature. (See System Configuration page 12)

The Select Sync Type function enables the **MX⁴** to accommodate as many types of VGA monitors as possible, as some monitors may function erratically without continuous synchronization (Figure 34). The **MX⁴** can generate either continuous sync signal or regular sync signal. If a user console monitor exhibits abnormal behavior, try changing this setting for the user port to which it is connected. **Perform steps 1-3 of Function Selection first.** To control the sync type generated for a user port:

1. Press **↑** or **↓** buttons to select the user port number.
2. Press the **←** button to toggle the sync type between regular and continuous.
3. Press **ENT** to confirm the selected setting, or
4. Press **ESC** to return to the Normal Display and retain the previous setting.

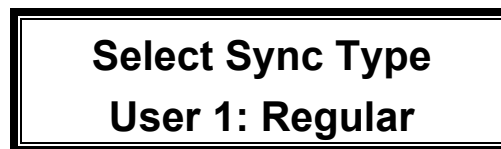

Figure 34 Select Sync Type

☞ Certain versions of MX4 hardware have the auto sync detection function built-in, which will disable this front panel function.

Reset MX⁴

The Reset **MX⁴** function lets you restart the **MX⁴** unit as if you had physically turned the unit's power off and back on again. However, the **MX⁴** will not perform the start-up test unless you hold down the **ENT** button during restart. **Perform steps 1-3 of Function Selection first.**

Display Serial Number (DSP Serial Numbr)

The Display Serial Number function lets you review the serial number of your MX⁴ unit. See Figure 35. **Perform steps 1-3 of Function Selection first.**

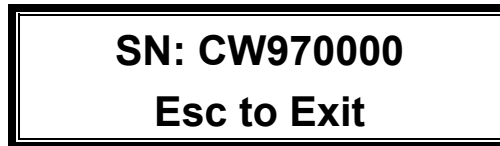

Figure 35 Display Serial Number

1. Press the **↑** or **↓** buttons until “DSP Serial Numbr” appears.
2. Press the **ENT** button to display the serial number of the unit.
3. Press **ESC** to return to the Normal Display and retain the previous setting.

Display Firmware Version (DSP Firmware Vsn)

The Display Firmware Version function lets you review the version of control firmware running on your MX⁴ unit. See Figure 36. **Perform steps 1-3 of Function Selection first.**

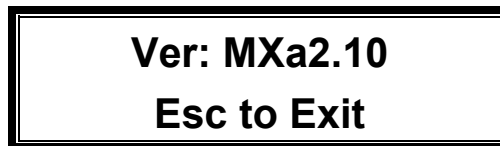

Figure 36 Display Firmware Version

1. Press the **↑** or **↓** buttons until “DSP Firmware Vsn” appears.
2. Press the **ENT** button to display the serial number of the unit.
3. Press **ESC** to return to the Normal Display and retain the previous setting.

Appendix C: MCUpdate Program

Introduction

MCUpdate is a Windows 95/98 based utility program designed to upload the MX⁴ firmware from a PC Windows environment into the MX⁴ unit. This document will guide you to install and run the MCUpdate program to update your MX⁴ with a new release of firmware.

The MCUpdate kit contains the following parts:

- 1 Floppy Diskette containing MCUpdate, setup programs and HEX file
- 1 DB9 to RJ11 Serial port adapter
- 1 4-wire Telephone cord

Installation

MCUpdate is designed to run on an industry standard PC, with a DB9 serial COM connector, running Windows 95 or Windows 98.

Installing MCUpdate program

1. Insert the MCUpdate diskette into the floppy drive.
2. Run the setup.exe program on the diskette and follow the step by step instruction to complete the MCUpdate program installation. The setup will install the program and file in C:\Program Files\MCUPDATE.

Connecting PC to MX⁴

1. Plug the DB9 to RJ11 Serial port adapter to your PC's DB9 serial port

If your PC has only a DB25 serial port, you need to convert it to DB9 using a standard DB25 to DB9 adapter available from your local PC store.

2. Plug one end of 4-wire telephone cord to the RJ11 port on the adapter, and plug the other end to the MX⁴ RJ11 admin port. (Figure 37)



Figure 37 MX⁴ Back Panel and Admin Port

MUpdate Operations

Planning before running MUpdate

- ☞ Please read this section carefully and plan ahead before you proceed. The MUpdate program **MUST RUN TO COMPLETION**. If it fails to complete the update procedure, the MX⁴ unit may become totally non-functional. If you have any questions on this regard, please contact Raritan Tech Support for assistance.
1. The MX⁴ unit must be running normally. Observe the LCD display, which will have a circulating Raritan message on the first line and scrolling user messages on the second line.
 2. If the MX⁴ is currently running a version of firmware prior to ver. 2.0, MUpdate will reset all configurations to default. You must login as an administrator and **MANUALLY COPY** the current configurations in the attached OSUI menu blanks so that you can **re-configure the system after the upgrade?** Firmware version release levels can be checked from the *Help Menu*, when logged in as an administrator.
 3. If you have a 2-tier MX⁴ system, you need to upgrade only the base unit. However, if you want to make full use of all features, you should upgrade the second tier units to as well. You don't need to perform step 2 for second tier units, unless you have local users on those second tier units.
 4. When MUpdate is executing, the MX⁴ will suspend all operations to perform the firmware update. It is advisable to log off all users of the MX⁴ system before running the MUpdate, but not necessary.

Running MUpdate

Begin from the Windows Start menu; select MUpdate from the Programs menu. Select MUpdate to begin the MUpdate program. (Figure 38)

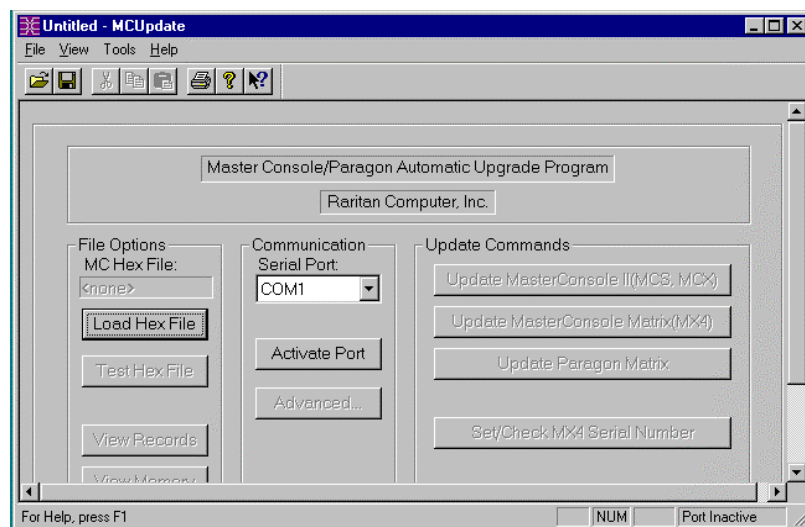

Figure 38 Running MUpdate Program

Loading firmware file

Load the MX⁴ firmware into the MCUpdate program memory. In the File Options section of the MCUpdate window click the button labeled *Load Hex File*. (Figure 39) In the pop up file Open dialog window, select MX4-*nnn*.hex, where *nnn* is a version number, then click the *Open* button.

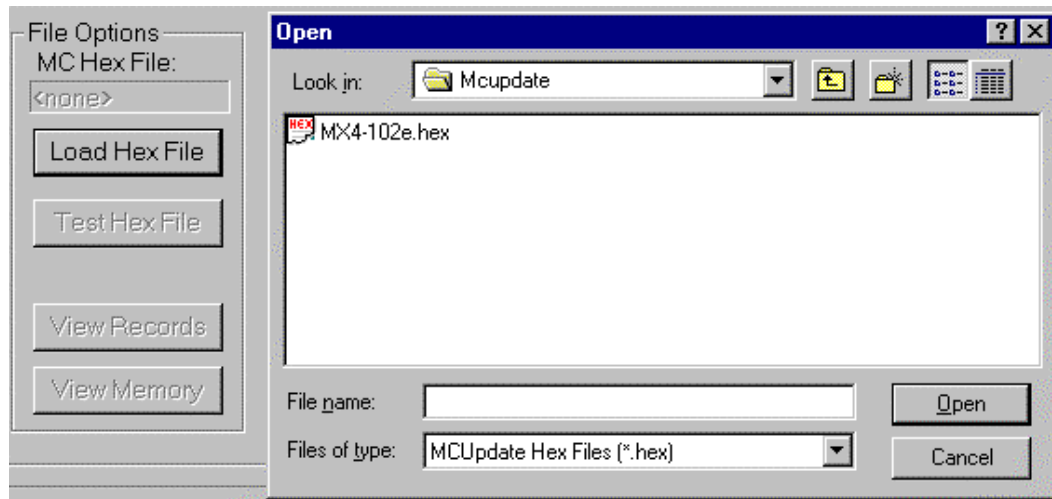

Figure 39 File Options Section

After the firmware is loaded into memory, you can click the button labeled *Test Hex File* to verify the content. This is an optional step.

Activate the PC Communication port

You must identify the PC serial port used to communicate with the MX⁴ unit. From the Communication section of the MCUpdate window, select the COM port you installed the DB9 to RJ11 adapter. (Default COM1) Then click the button labeled *Activate Port*. (Figure 40)



Figure 40 Communication Section

Update MX⁴

MCUpdate will upload the firmware into the MX⁴ unit, replacing the older version stored in a flash memory chip. In the Update Commands Section (Figure 41), as a test procedure, click the button labeled *Set/Check MX4 Serial Number* to validate that MCUpdate and the MX⁴ unit are communicating properly. This test will retrieve the serial number of your MX⁴ unit and display it. Click *OK* to end the communications test.

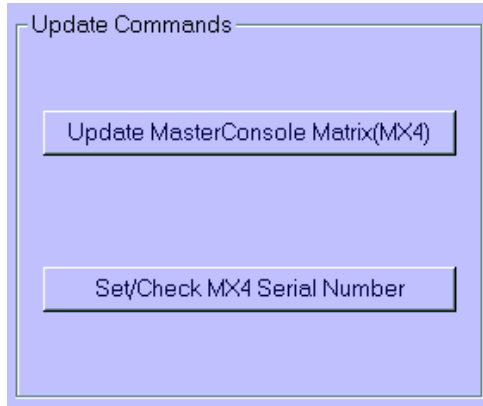

Figure 41 Update Commands Section

You are now ready to upload the new firmware file. Click the button labeled *Update MasterConsole Matrix (MX4)*. The serial number will be displayed. Click *OK* to continue. It will take about 2 minutes to complete this step. Make sure there are no interruptions of power and avoid performing any activities on the PC or MX⁴ unit during the MCUpdate upload. MCUpdate will display the progress of firmware transfer, record by record, page by page, and block by block. There are total of 8 blocks, 64 pages in each block, and 16 records in each page.

Upon completion, the MX⁴ will reset and restart itself. Close the MCUpdate program window on your PC.

If the version of firmware you replaced was prior to version 2.0, you must manually reload the system and user configurations that were copied prior to the MCUpdate program being executed. Refer to Planning before running MCUpdate step2.

Congratulation! You have done it. Enjoy the new features of the new MX⁴ Release.

Attachments

MX⁴ OSUI Menu Forms

System Configuration

MX4 ID: _____

Security

Timeout: _____ Logout _____ Min

Access Mode: _____

V-Share Mode: _____

Allow Blank Password: _____

Login Blank: _____ Minutes

Login Help Mode: _____

Ct Sync: 1: _____ 2: _____ 3: _____ 4: _____

Help Messages
Status Line

Channel Configuration Menu

MC: _____

Page 1/2

Ch. ID	Name	Sec	Scn
01	_____	_____	_____
02	_____	_____	_____
03	_____	_____	_____
04	_____	_____	_____
05	_____	_____	_____
06	_____	_____	_____
07	_____	_____	_____
08	_____	_____	_____

Help Messages
Status Line

Channel Configuration Menu

MC: _____

Page 2/2

Ch. ID	Name	Sec	Scn
09	_____	_____	_____
10	_____	_____	_____
11	_____	_____	_____
12	_____	_____	_____
13	_____	_____	_____
14	_____	_____	_____
15	_____	_____	_____
16	_____	_____	_____

Help Messages
Status Line

User Configuration

User: John

Page 1/1

Name	Sc	Adm	Connection
Admin	_____	_____	None
_____	_____	_____	None
_____	_____	_____	None
_____	_____	_____	None
_____	_____	_____	None
_____	_____	_____	None
_____	_____	_____	Wins95.Bob
_____	_____	_____	_____

Help Messages
Status Line

Appendix D: OverView Program

Introducing OverView

OverView is the PC Windows 95/98 program that provides an interface with the MasterConsole MX⁴ enabling the administrator to perform the following functions:

- Maintenance of MX⁴ configuration data in a Windows environment.
- Uploading and downloading of MX⁴ configuration data to a PC
- Real-time log of MX⁴ activity with reporting capabilities.

The OverView Package

Raritan's OverView package includes the following items:

- 1 Floppy Diskette containing OverView and setup programs
- 1 DB9(F) to RJ11 serial port adapter (part number A9FRJ11)
- 1 4-wire telephone cord

Installation

OverView is designed to run on a PC, with a DB9 serial COM connector, running Windows 95 or Windows 98.

Installing OverView program

3. Insert the OverView diskette into the floppy drive—assumed to be A.
4. Click the Windows *Start* button and then click on the *Run* button. Either type—A:\setup.exe—into the *Open* window—or use the *Browse* button and select “Setup.exe” —and then click on *OK*. Follow the step by step instructions to complete the OverView program installation. Setup will install the program in C:\Program Files\MC OverView

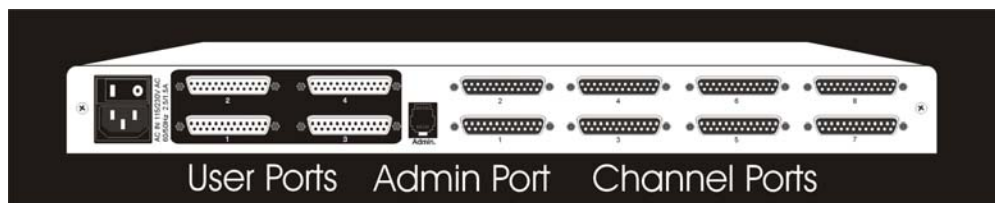

Figure 42 MX4 Back Panel showing RJ11 Admin Port

Connecting PC to MX⁴

3. Plug the DB9 to RJ11 adapter (A9FRJ11) into PC's DB9 serial port. ***If your PC has only a DB25 serial port, you need to convert it to DB9 using a standard DB25 to DB9 adapter available from your local PC store.***
4. Plug one end of the 4-wire telephone cord into the RJ11 port on the adapter and the other end into the MX⁴ RJ11 Admin port.

OverView Operations

Running OverView

From the Windows Start menu, select “MC OverView” from the Programs menu. Select “MC OverView” to begin the MX⁴ OverView program. (Figure 43)

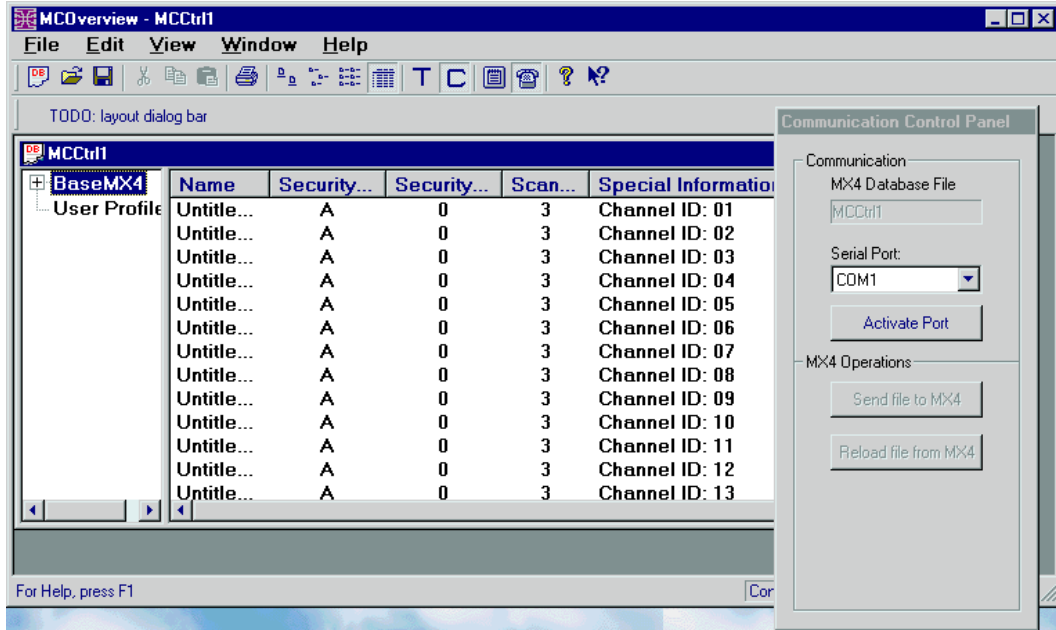

Figure 43 OverView Started

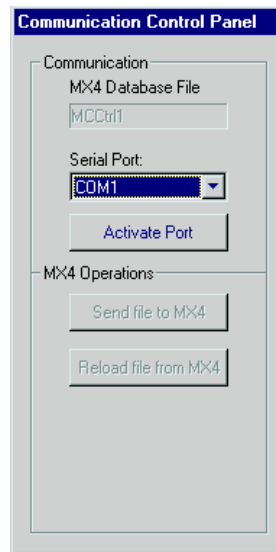

Figure 44 Communication Control Panel

Activate PC Communication and Login

OverView activates the PC serial port to communicate with the MX⁴ unit. From the Communication Control Panel select the COM port you installed the DB9 to RJ11 adapter—default COM1 (Figure 44). Click the button labeled *Activate Port*. OverView will initiate the communication with the MX⁴ unit. It retrieves the serial number from the MX⁴ unit and displays it in an information window. Click the *OK* button to continue. OverView will prompt you to login as an administrator (Figure 45). Enter an administrative user name and the password—admin/raritan—if needed, and then click the *OK* button. OverView will validate the admin name and password with the MX⁴ unit and will download a copy of the configuration file from MX⁴ unit into the PC. You can now perform maintenance functions.

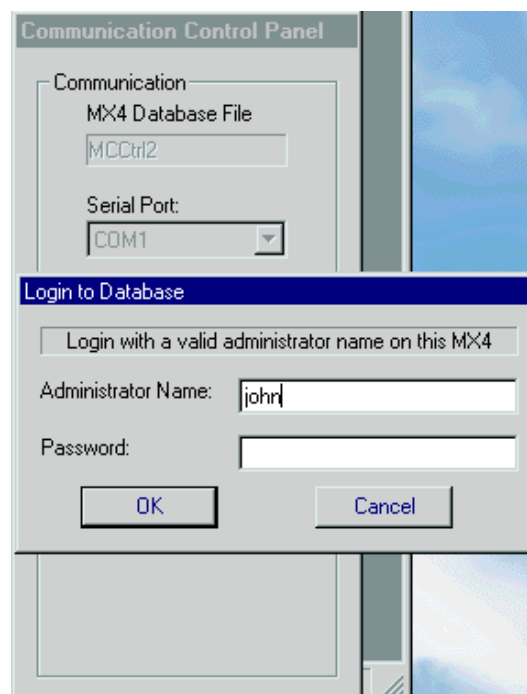

Figure 45 Login to Database

Real Time MX⁴ Monitoring

OverView allows you to monitor all user activity of in real time (Figure 46). From the View Menu, select *Log Window* to activate monitoring. It displays any user's login from a specific user station, user's logout and the duration of the session, user's selection of computers, and any failed login attempts. These activities are saved in a log file for later review. The log file contains all user activities performed while the log window is activated.

Edit User Profiles

OverView allows you to change, add or delete a user's profile. To edit a user's profile, click *User Profiles* on the left side of the main window to display the user list. Double click the user name to edit it. An edit window will pop up to allow you to edit the profile (Figure 47). Modify any field as required. Click *OK* to close the window.

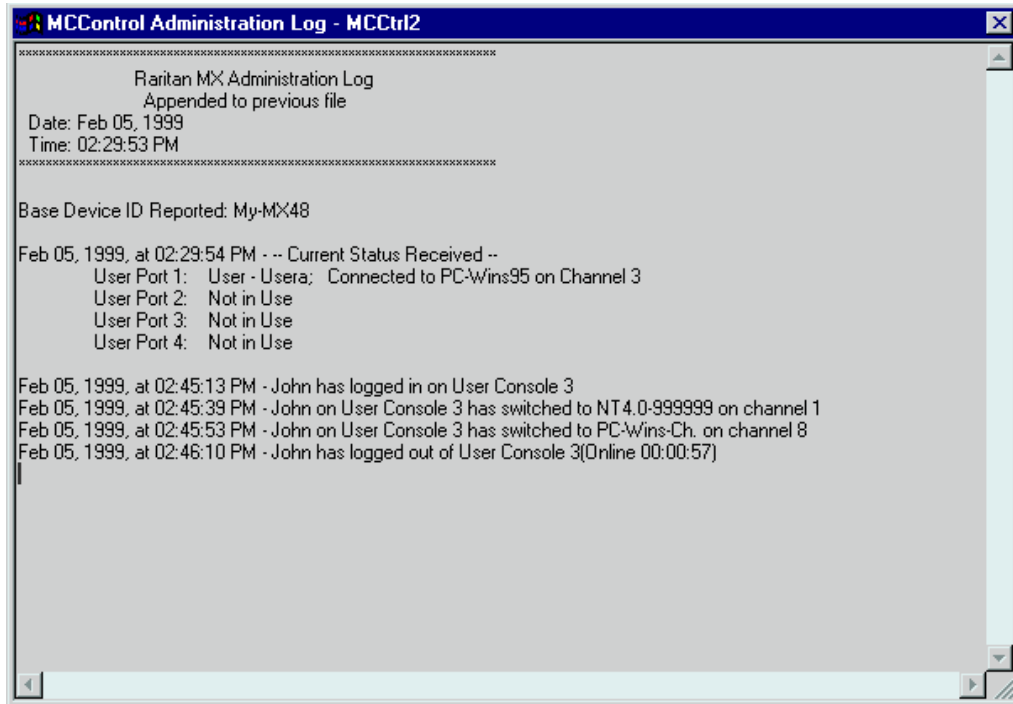

Figure 46 Log Window

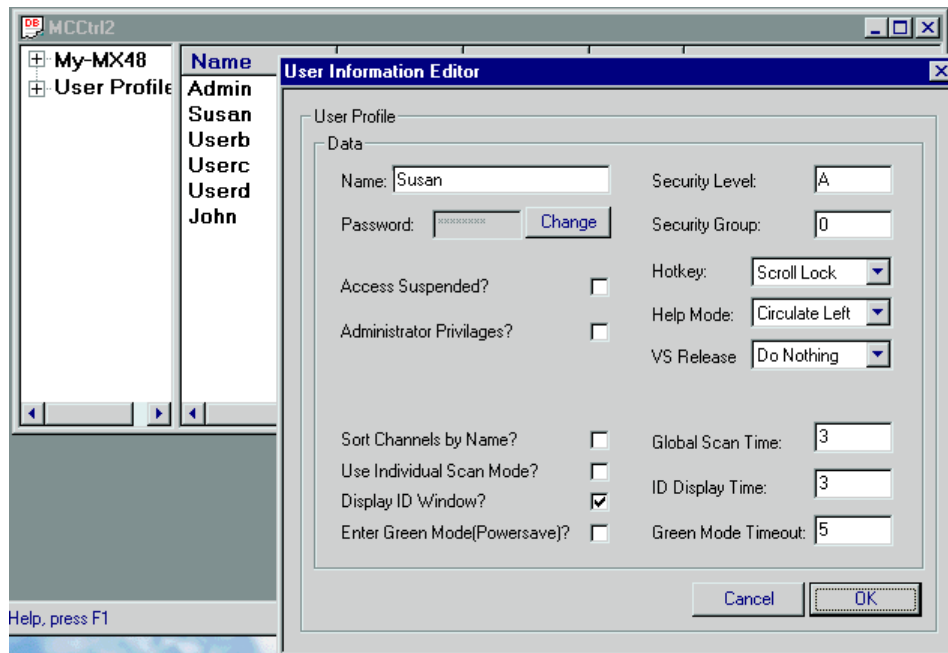

Figure 47 Edit User Profile

Edit Device Profile

Use this feature to change computer names and profiles, either on a base or tier MX⁴, or second tier MasterConsole. To edit a computer, open the device list by clicking the *square plus sign* on the left of the MasterConsole name(s). Double click a computer or a MasterConsole from the list. An edit window will open to allow you to edit the device profile (Figure 48).

Save a Copy of Configuration File to a PC Disk—Backup

You can save—backup— a copy of the current configuration file to a PC disk file. The saved configuration can be opened and uploaded to an MX⁴ if necessary or as a quick way to set up a new MX⁴ unit. From the File menu, select *Save* or *Save As* to backup the active configuration file to a PC disk file.

Upload Configuration File to MX⁴

After editing the user profiles, computers and/or MasterConsole(s) information, the changed configuration file must be uploaded to the MX⁴ unit to become the active version that the MX⁴ unit operates with. **Before uploading to the MX⁴ save a copy in a PC disk file for later reference.** To update the MX⁴ configuration, click the *Send file to MX4* button from the communication panel. OverView will upload the new configuration file to the MX⁴ unit—during this upload the MX⁴ unit will temporarily suspend all operations.

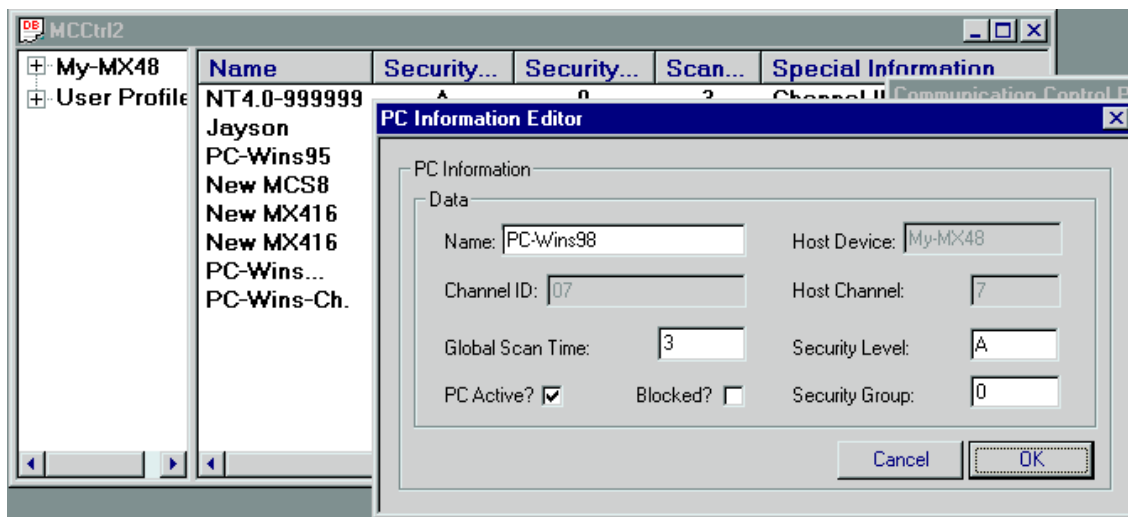

Figure 48 Edit Device Profile

Download Configuration File from MX⁴

From the communication panel, click the *Reload Configuration file from MX4* button to download a copy of the configuration file from MX⁴. This will override any currently stored configuration file on the PC. This feature allows you to update the configuration file on the PC if maintenance has been performed on the MX⁴ from a user station.

Open Saved Configuration File from a PC Disk File

Select *Open* from the File menu, and then select the file name of the stored configuration data. This opens a copy of a previously saved configuration file from a PC disk file. Select the *Send to MX4* button to upload this saved configuration file to the connected MX⁴ unit or easily set up all necessary configuration data on a new MX⁴ unit.

MC OverView FAQ's

<p>After I began the OverView, I'm getting "MX4 device is not responding" after clicking "Activate Port".</p>	<ol style="list-style-type: none"> 1. Make sure DB9 to RJ11 converter is plugged in to PC DB9 serial port properly, and the 4-wire telephone cable is connected between the converter and MX⁴ RJ11 Admin port. 2. Make sure a proper Comm port number is selected. 3. You may need to re-cycle the MX⁴ AC power. Please note: This will not affect the computers connected to the MX⁴, except all users will have to login again. 4. There may be a defective serial port on your Windows 95/98 PC.
<p>After a certain period of OverView operation, when I click "Send to MX4", the Windows hourglass stays on and will not go away.</p>	<ol style="list-style-type: none"> 1. Check the cable connection between PC and MX⁴. 2. Most likely the serial communication between PC and MX⁴ is broken. Press <Ctrl+Alt+Del> to bring up the "Close Program" windows. Select "MCOverView – MCCTRL1" entry to see if it has a "Not responding" status. If it does, click "End task" to terminate OverView. restart the OverView from the Start Menu. If it does not have a "Not responding" status, it is waiting for a slow PC to perform.
<p>My PC has only DB25 serial port, not DB9. What can I do to run MX⁴ OverView?</p>	<ol style="list-style-type: none"> 1. You can convert a DB25 to DB9 using a standard adapter from your local PC store.

Appendix E: Glossary

Administration Menu		For installing and configuring access to the MX ⁴ . Use is restricted to those with administrator privileges.
AutoScan		When activated, the MX ⁴ automatically cycles through channels, displaying each computer's video for a specified time interval.
AutoSkip		When activated, channel selection is restricted to active channels.
Base Unit		The MX ⁴ unit to which computers and/or other MasterConsole units are connected in a two-tier configuration.
C Model		MasterConsole II models MCC4, MCC8, and MCC16.
Channel		The 25-pin connector identifying where a device is connected to the MX ⁴ . There are 8 channels on model MX48 units, and 16 channels on model MX416 units.
	Active	A channel is active when a connected device is powered on.
	Inactive	A channel is inactive if no device is connected to it or if the connected device is powered off.
Channel Configuration Menu		For editing computer and device names, changing security classes, and assigning channel-specific scan rates.
Channel ID Number		The specific channel number to which a device is connected.
Computer Name		A label of up to 12 characters assigned by an administrator for a device connected to an MX ⁴ channel.
Configuration	One-Tier	Only computers are connected directly to a single MX ⁴ unit
	Two-Tier	A mix of devices—computers and MasterConsole units—are connected to a base MasterConsole unit.
Device		A computer or any MasterConsole unit—P model, MCC, MCX or MCS model, MX ⁴ model— is connected to an MX ⁴ channel.
Function Selection Screen		For accessing front panel control functions.
Green Mode		A field in the User Profile Menu for toggling the PowerSave feature on and off.
Hot-key		For activating the on-screen user interface. To activate the on-screen user interface, press the hot-key—default <ScrollLock>—twice rapidly.
ID Display		A single-line display shown on the monitor to identify the currently selected channel.

Key Number	Located in the left-hand column of the Selection Menu. To quickly select a channel, press the corresponding key number on the keyboard when the Selection Menu is displayed.
LCD Display	Liquid-crystal display screen on the MX ⁴ front panel for displaying statuses and controlling administrative functions.
Local Console	The keyboard, monitor, and mouse plugged into the local KVM port.
Logging In	Entering a user name to gain access to the MX ⁴ system.
Login Screen	For logging in to the system as a user or administrator.
Logout	Disconnects a user from the system.
Menu	An MX ⁴ on-screen user interfaces display.
Menu F Keys	Function keys used for accessing on-screen user interface menus.
Normal Display	Displayed on the LCD and showing the on going operating status of the MX ⁴ .
MX ⁴ OverView™ Program	The PC Windows 95/98 program that provides an interface with the MasterConsole MX ⁴ enabling the administrator to perform maintenance functions and real-time user activity tracking.
Password	Used in conjunction with user name to gain access to the MX ⁴ .
PowerSave	Allows a properly equipped monitor to operate in energy save mode. See also Green Mode.
PublicView	Feature that controls the video sharing of a computer that is being selected and operated by another user.
Remote KVM Module	Optional unit that enables the MX ⁴ to connect to computers or user consoles up to 325 feet away.
Reserved Channels	In a two-tier configuration, the channels on the base MX ⁴ unit allocated to connect second-tier MasterConsole(s).
S Model	MasterConsole II models MCS4, and MCS8
Satellite Unit	Second-tier MasterConsole II X model located more than 30 feet from the base unit and connected through its Remote Access port.
Scan	On-screen user interface function for activating AutoScan.
Scan Mode	Field in the User Profile; can be set to either Global or Individual. See also Scan Rate.
Scan Rate	The time interval—in seconds—that a channel's computer is to remain displayed on the monitor when AutoScan is activated.
	Global Scan Rate
	The scan rate used for all channels when the Scan Mode

		field in the User Profile is set to Global.
	Channel-Specific (Individual) Scan Rate	Scan rate specified for each channel when the Scan Mode field in the User Profile is set to Individual. Channel-specific scan rates are set in the Channel Configuration submenu of the Administration Menu.
Security Code		Letter/number set assigned to each user and computer to establish user-access rights.
	Class	Refers to the entire security code.
	Level	Refers to the letter in the security code.
	Group	Refers to the number in the security code.
Selection Menu		For selecting a computer or device.
Set LCD Contrast Screen		For adjusting the contrast of the LCD on the MX ⁴ front panel.
Set-Password Screen		Enables the administrator to password protect the functions on the LCD.
Set Tier Screen		For connecting second-tier user ports to first-tier channels.
Sorting		Order of the channels listed in the Selection Menu—either by channel ID or by name. Pressing F12 toggles the sort criterion when a Selection Menu is displayed.
Start-Up Display		Displayed on the LCD when the MX ⁴ is turned on—the system checks for the status of computers and user connections. After this start-up test, the system goes to normal display.
System Configuration		For allowing and disallowing blank passwords, turning Time Out on and off, changing the Time Out interval, turning the Login Screen on and off, and changing the Login interval.
Time Out		Length of time that a user port can remain idle—that is, since the previous keyboard/mouse or front panel operation—before the connected console is automatically logged out. User must enter an authorized user name to re-establish access after Time Out.
User Configuration		Used by the administrator for adding, deleting, and changing user names, security codes, and administrator privileges.
User Console		The keyboard, monitor, and mouse plugged into a user port on the MX ⁴ back panel.
User Name		Name a user types to log in to the system.
User Port		The 25-pin connector where a user console (keyboard, monitor, and mouse) is connected to an MX ⁴ .
User Profile		For setting and changing user passwords and preferences.
X Model		MasterConsole II models MCX4, MCX8, and MCX16. Includes Port Out for connecting a Remote Access Kit.

Appendix F: Troubleshooting

No power.	<ol style="list-style-type: none"> a. Check power cord and make sure power switch is turned on. b. Check cable connection from computer to MX⁴. c. MX⁴ power supply has built-in surge protection. If you cannot regain power during a power recycling process, power off the unit. Wait for 15–20 seconds, and then turn on again.
No video display for one or all computers.	<ol style="list-style-type: none"> a. Check video cable's connection to the computer. b. Check the monitor and computer. Turn off the power to MasterConsole and computers. Connect the monitor to the computer directly, boot the computer and make sure the monitor has the proper display. If it does not, either the problem is with your computer or the monitor is not compatible with your computer. If it does display, continue to Troubleshooting item
The monitor cannot correctly display the video output from some of the computers.	<ol style="list-style-type: none"> a. The monitor probably does not match the video outputs. If the monitor is a single-mode-type VGA, all computers must have the same type of video output. b. See Select Sync Type on page 32 if a change of sync type is necessary. c. This problem occurs most often with some IBM PS/2s and IBM 63xx, 85xx, and 95xx monitors. The intelligent type display card outputs video signals based on the monitor ID-pin setting in the connector of the monitor cable. If the ID-pin setting is correct, the monitor at MasterConsole may have no display, become monochrome instead of color, or become unstable. If this is the case, you will need to provide a proper ID pattern for the display card. Call Raritan Computer Technical Support for help.
All computers powered up without keyboard error, but the keyboard at MX ⁴ has no control—cannot input to any computer.	<ol style="list-style-type: none"> a. Make sure the keyboard is connected firmly into the cable connector and the 25-pin cable is connected to the MX⁴. Disconnect and reconnect keyboard. b. Replace keyboard. MasterConsole allows hot reconnection of the keyboard at its user console port. c. In a two-tier configuration, check that the MX⁴ with the keyboard connected is the base unit.

<p>Repeated "KB ERROR" at computer power-up.</p>	<ul style="list-style-type: none"> a. The keyboard cable from the computer to the MX⁴ is loose. Secure the connection and power up the computer again. b. If the problem occurs after the MX⁴ has been installed for a period of time and occurs on computers that have previously worked with MX⁴, then some components are out of order. Verify that the computer works with the keyboard when connected directly. Then contact your dealer or Raritan Computer Technical Support for service.
<p>After a period of trouble-free operation, the keyboard attached to the MX⁴ locks—unable to input keystrokes—when a particular computer is selected, but works normally when other computers are selected.</p>	<ul style="list-style-type: none"> a. The most likely cause of the problem is either a voltage spike—increase— or a brownout—decrease—in the power supply, which would cause the microprocessors in the MX⁴ to malfunction. A short-term solution to the problem is to try to recover operation by turning the MX⁴'s power switch off and on. Then, if necessary, restart all computers. The long-term solution to avoid this problem is to power the MX⁴ from a UPS. b. Check keyboard connection.
<p>Repeated "MOUSE INSTALLATION FAILURE" at computer power-up.</p>	<ul style="list-style-type: none"> a. The mouse cable from the computer to the MX⁴ is loose. Secure the connection, and power up again. b. If the problem occurs only with new computers that are being added to the system, the firmware in the KVM—an internal mouse emulator—may need to be upgraded to a later version to be compatible with newer computers. Contact your dealer or Raritan Computer Technical Support for service.
<p>After a period of trouble-free operation, the mouse attached to the MX⁴ locks—unable to control mouse functions—when a particular computer is selected, but works normally when other computers are selected.</p>	<ul style="list-style-type: none"> a. Try to identify whether the problem is originating from the computer by reconnecting the computer to a different channel with a different cable. Then power up the computer. If the problem is not with the cable or with the specific channel, then connect the mouse directly to the computer. If the problem persists, then the computer's mouse port is out of order. Otherwise, contact your dealer or Raritan Computer Technical Support. b. If the problem occurs after the MX⁴ has been installed for a period of time and occurs to computers that have previously worked with the MX⁴, then some components are out of order. Contact your dealer or Raritan Computer for service.
<p>Unit does not operate in on-screen user interface mode.</p>	<ul style="list-style-type: none"> a. Replace keyboard. OSUI works only with PS/2 or extended AT-style keyboards.

Appendix G: Specifications

MX⁴ Models

Model	MX48 (8-channel model)	MX416 (16-channel model)	MX432 (32-channel model)
Dimensions	17.0"(W) x 10.5"(D) x 1.75"(H)	17.0"(W) x 10.5"(D) x 3.5"(H)	17.0"(W) x 10.5"(D) x 7.0"(H)
Weight	2.8 kg (6.1 lb.)	3.8 kg (8.4 lb.)	6.6 kg (14.4 lb.)
Power	115V/230V Auto Sensing 60 Hz / 50 Hz 0.3/0.2A	115V/230V Auto Sensing 60 Hz / 50 Hz 0.3/0.2A	115V/230V Auto Sensing 60 Hz / 50 Hz 0.3/0.2A
Operating Temperature	0–50°C (32-122°F)	0–50°C (32-122°F)	0–50°C (32-122°F)

Cable Kits

Universal Cable Kits: For connecting computer to MX⁴

PART NO.	LENGTH	CONNECTORS
CCP06U	2' (0.6 M)	DB25(M) to HD15(M), 2x mini-DIN6(M)
CCP20U	6.5' (2 M)	DB25(M) to HD15(M), 2x mini-DIN6(M)
CCP40U	13' (3 M)	DB25(M) to HD15(M), 2x mini-DIN6(M)
CCP60U	20' (6 M)	DB25(M) to HD15(M), 2x mini-DIN6(M)
CCP90U	30' (9 M)	DB25(M) to HD15(M), 2x mini-DIN6(M)

Each Universal Cable Kit comes with adapters for AT-style keyboard and serial mouse: (1) DIN 6F to DIN 5M and (1) DIN 6F to DB9F

Console Cable: For connecting MX⁴ User Port to User Console

PART NO.	LENGTH	CONNECTORS
CCP06F	2' (0.6 M)	DB25(F) to HD15(F), 2x mini-DIN6(F)
CCP20F	6.5' (2 M)	DB25(F) to HD15(F), 2x mini-DIN6(F)
CCP40F	13' (3 M)	DB25(F) to HD15(F), 2x mini-DIN6(F)
CCP60F	20' (6 M)	DB25(F) to HD15(F), 2x mini-DIN6(F)
CCP90F	30' (9 M)	DB25(F) to HD15(F), 2x mini-DIN6(F)

Cascading Cable: For connecting MX⁴ to tier to another MX⁴

PART NO.	LENGTH	CONNECTORS
CCP10E	3' (1 M)	DB25(F) to DB25(M)
CCP20E	6.5' (2 M)	DB25(F) to DB25(M)
CCP40E	13' (3 M)	DB25(F) to DB25(M)
CCP60E	20' (6 M)	DB25(F) to DB25(M)
CCP90E	30' (9 M)	DB25(F) to DB25(M)

Accessories

Cat5 Reach	Cat5 Reach extends the keyboard, mouse and monitor, computers, and cascaded units up to 1000 feet apart by means of a Category 5 UTP cable. The product consists of a transmitter/receiver pair. Category 5 UTP cable not included.
BRKT1U	19" Rack Mount Bracket (for MX48)—1U
BRKT2U	19" Rack Mount Bracket (for MX416)—2U
BRKT4U	19" Rack Mount Bracket (for MX432)—4U
APSMAC	Converter for Mac (Mac ADB and video to PS/2 k/b, PS/2 mouse, and VGA ports)
APSSUN	Converter for Sun (Sun k/b and video to PS/2 k/b, PS/2 mouse, and VGA ports)
ASOGVGA	Sync on green converter for HP9000 or SGI with HD15 video
ASGIVGA	Sync on green converter for SGI with 13W3 video
ARSVGA	Sync on green converter for RS/6000 with 13W3 video
APSUSB	USB to PS/2 converter
AUATC	ASCII Terminal Converter (serial to PS/2)—connect ASCII device up to 1000 feet away from MX ⁴ with Category 5 cable

Appendix H: MX⁴ Configurations

Basic: 4 Users and Up to 16 Computers

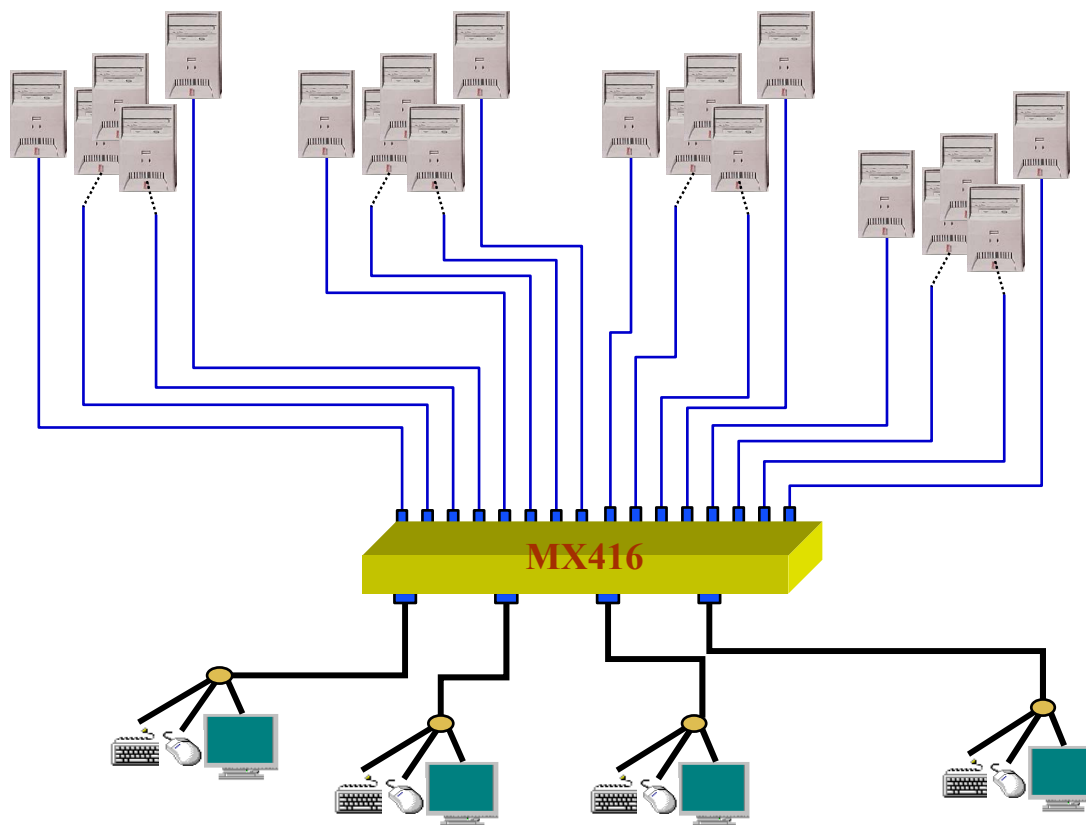

Figure 49 MX⁴ Basic Configuration

4 Users and Up to 64 Computers Matrix

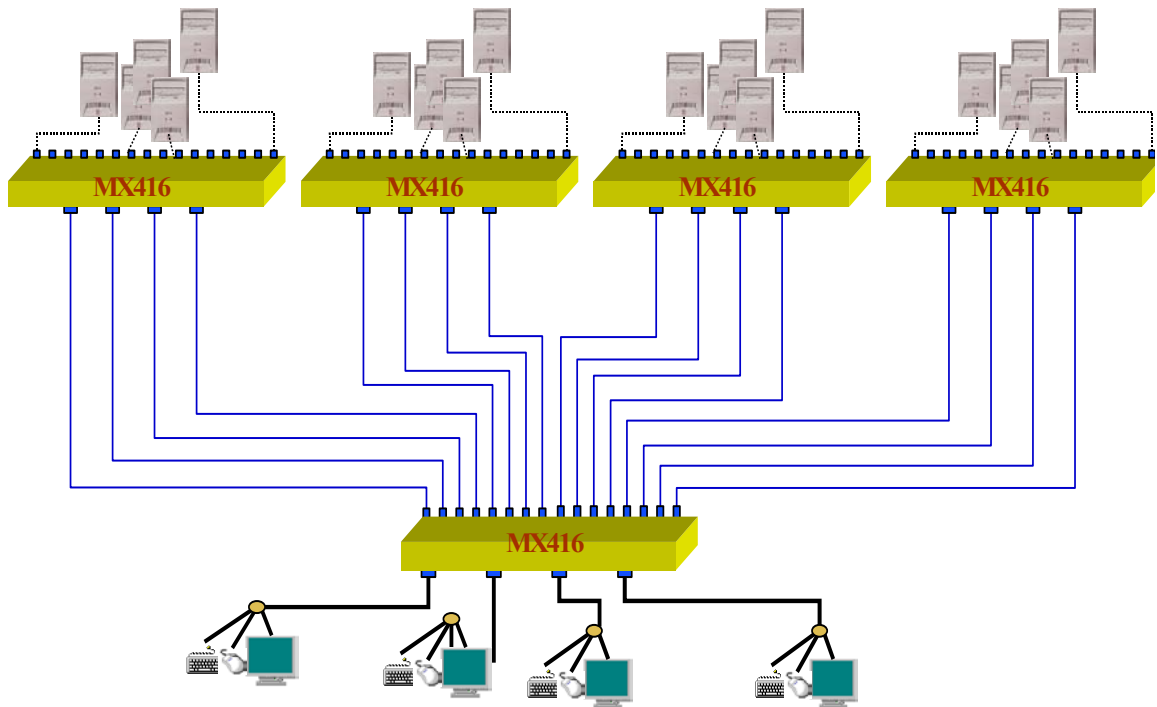

Figure 50 MX⁴ 4x64 Configuration

MX⁴ 4 Users and Up to 256 Computers Matrix

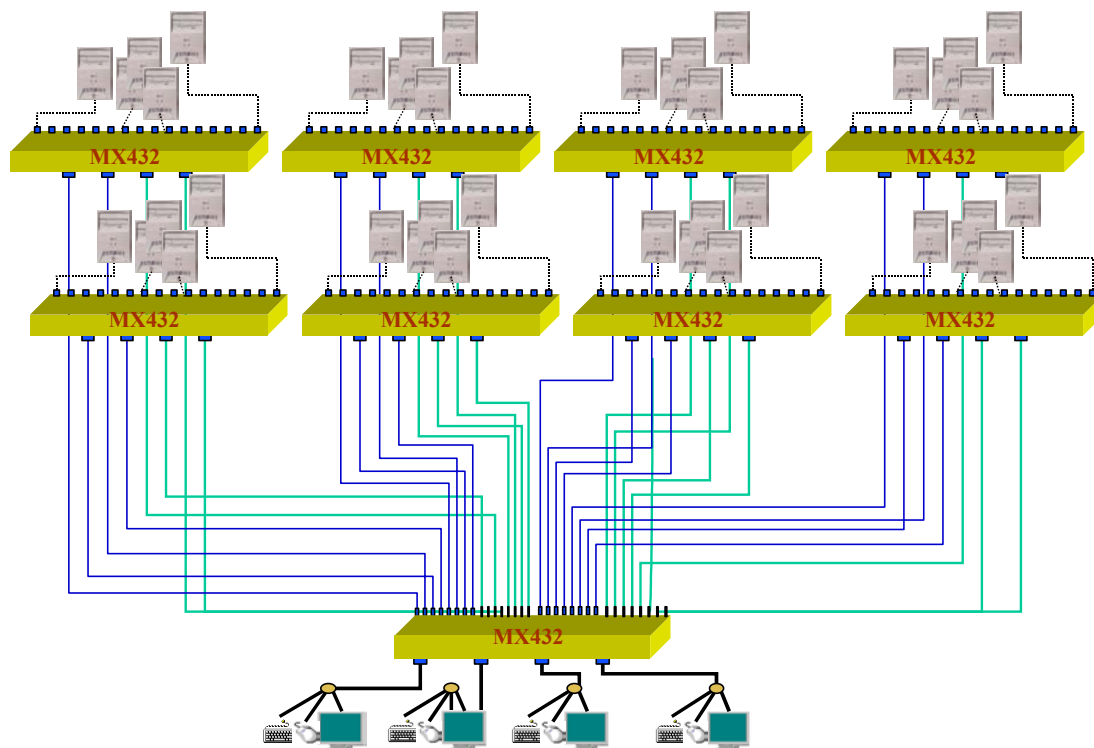

Figure 51 MX⁴ 4x256 Matrix Configuration

This configuration allows 4 users to access 256 computers. In this configuration, all MX⁴ units must be Release 2 or greater.