

Full IP67 Aluminum WRD Rugged PC Series

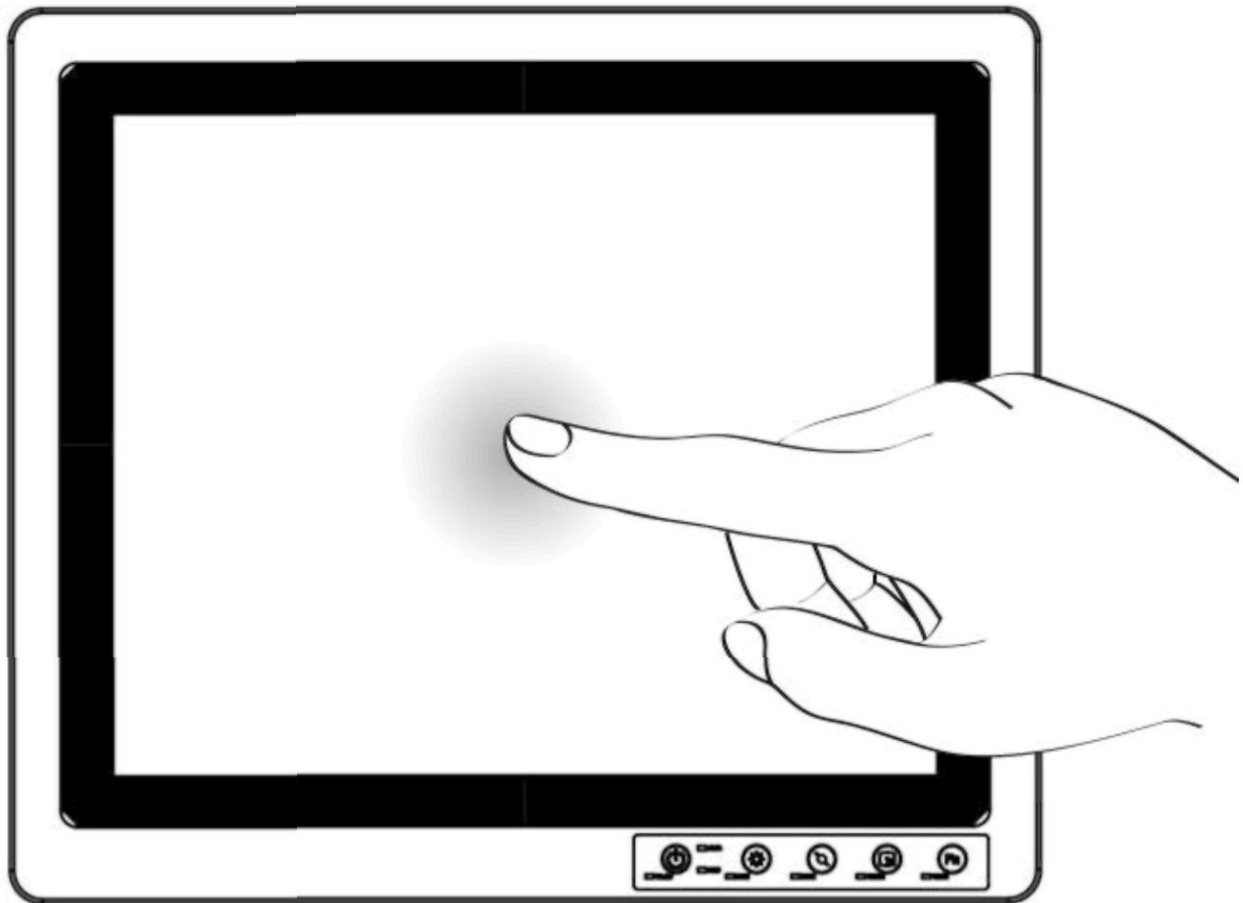

User Manual

Version 1.0



Copyright Notice

No part of this document may be reproduced, copied, translated, or transmitted in any form or by any means, electronic or mechanical, for any purpose, without the prior written permission of the original manufacturer.

Trademark Acknowledgement

Brand and product names are trademarks or registered trademarks of their respective owners.

Disclaimer

We reserves the right to make changes, without notice, to any product, including circuits and/or software described or contained in this manual in order to improve design and/or performance. We assume no responsibility or liability for the use of the described product(s), conveys no license or title under any patent, copyright, or masks work rights to these products, and makes no representations or warranties that these products are free from patent, copyright, or mask work right infringement, unless otherwise specified. Applications that are described in this manual are for illustration purposes only. We make no representation or warranty that such application will be suitable for the specified use without further testing or modification.

Warranty

Our warranty that each of its products will be free from material and workmanship defects for a period of one year from the invoice date. If the customer discovers a defect, we will, at its option, repair or replace the defective product at no charge to the customer, provided it is returned during the warranty period of one year, with transportation charges prepaid. The returned product must be properly packaged in the original packaging to obtain warranty service.

If the serial number and the product shipping data differ by over 30 days, the in-warranty service will be made according to the shipping date. In the serial numbers the third and fourth two digits give the year of manufacture, and the fifth digit means the month (e. g., with A for October, B for November and C for December).

For example, the serial number 1W08Axxxxxxx means October of year 2008.

Customer Service

We provide service guide for any problem as follow steps: First, visit the website of our distributor to find the update information about the product. Second, contact with your distributor, sales representative, or our customer service center for technical support if you need additional assistance. You may have the following information ready before you call:

- Product serial number
- Peripheral attachments
- Software (OS, version, application software, etc.)
- Description of complete problem
- The exact wording of any error messages

In addition, free technical support is available from our engineers every business day. We are always ready to give advice on application requirements or specific information on the installation and operation of any of our products. Please do not hesitate to call or e-mail us.

Safety Information

WARNING!



Always completely disconnect the power cord from your chassis whenever you work with the hardware. Do not make connections while the power is on. Sensitive electronic components can be damaged by sudden power surges. Only experienced electronics personnel should open the PC chassis.

CAUTION!



Always ground yourself to remove any static charge before touching the CPU card. Modern electronic devices are very sensitive to static electric charges. As a safety precaution, use a grounding wrist strap at all times. Place all electronic components in a static-dissipative surface or static-shielded bag when they are not in the chassis.

Safety Precautions

- Please read these safety instructions carefully.
- Please keep this user's manual for later reference.
- Please disconnect this equipment from any AC outlet before cleaning. Do not use liquid or spray detergents for cleaning. Use a damp cloth.
- Do not touch the LCD panel surface with sharp or hard objects.
- For pluggable equipment, the power outlet must be installed near the equipment and must be easily accessible.
- Keep this equipment away from humidity.
- Place this equipment on a reliable surface during installation. Dropping it or letting it fall could cause damage.
- The openings on the enclosure are for air convection. Protect the equipment from overheating. **DO NOT COVER THE OPENINGS.**
- Make sure the voltage of the power source is correct before connecting the equipment to the power outlet.
- Position the power cord so that people cannot step on it. Do not place anything over the power cord.
- All cautions and warnings on the equipment should be noted.
- If the equipment is not used for a long time, disconnect it from the power source to avoid damage by transient over-voltage.
- Never pour any liquid into an opening. This could cause fire or electrical shock.
- Never open the equipment. For safety reasons, only qualified service personnel should open the equipment.

- If any of the following situations arises, get the equipment checked by service personnel:
 - The power cord or plug is damaged.
 - Liquid has penetrated into the equipment.
 - The equipment has been exposed to moisture.
 - The equipment does not work well, or you cannot get it to work according to the user's manual.
 - The equipment has been dropped and damaged.
 - The equipment has obvious signs of breakage.
- Do not leave this equipment in an uncontrolled environment where the storage temperature is below -10°C (14°F) or above 60°C (140°F). It may damage the equipment.
- **CAUTION** – Use recommended mounting apparatus to avoid risk of injury.
- **WARNING** – Only use the connection cords which comes along with the product, when in doubt, please contact the manufacturer.
- Provision shall be made to provide transient protection device to be set at a level not exceeding 140% of the rated voltage at the power supply terminals of the apparatus.
- **WARNING** – The equipment should be adequately protected from direct light when installed indoor or outdoor.

Contents

Contents	6
Introduction	7
Features	7
Package Contents.....	8
Product Overview.....	9
Getting Started	10
Turning On Your Device	10
Adjusting the LCD Display Brightness	11
Calibrating Touch Screen	12
Turning Off Your Device	14
Installation	15
Wiring Requirements	15
Connecting the Interface	16
Mounting Solution	18
Specification	22
Hardware Specifications	22
Appendix	24
Appendix A: Cleaning the Monitor	24
Appendix B: Statement of Regulatory Approval	25

Introduction

iTechLCD WRD Series consists of rugged and unusually well-sealed vehicle or stationary-mount Panel PCs available in a wide variety of configurations. Depending on the intended application, WRD panels have been available with 5-wire resistive touch displays measuring 8.4, 10.4, 12.1 or 15-inches diagonally. Since the sealed nature and high reliability requirements of the WRD line precluded fans and cooling slots, WRD Panel PCs were designed with low power processors that didn't generate a lot of heat. That meant either Intel Cedar Trail or, more recently, Intel Bay Trail processors. While even Bay Trail is still based on the Intel Atom processor architecture, higher end quad-core Bay Trail chips such as the quad-core N2930 used in several WRD models have grown quite powerful. Sometimes, however, an even larger display is needed, and even higher performance, and that's where the new 19-inch WRD panels come in.

This new 19-inch WRD panel does not only offer considerably more screen real estate than a 15-inch model — about 90% more in fact — but the larger case also provides enough extra heat dissipation to allow the use of Intel Haswell Core processors with their higher thermal design power and significantly higher performance.

Features

- Intel Haswell Core i5-4300U turbo max 2.6 GHz
- 19" SXGA High brightness panel, 400 nits
- Sunlight readable, transfective, resistive touch LCD Panel
- Fanless, streamlined enclosure for highly efficient heat dissipation
- Front side buttons, one dedicated button to enable/disable touch screen interface
- Built in to withstand extreme temperatures (-10 deg C to 60 deg C)
- 9-36 V DC input (with isolation)
- Operable in 5-95% humidity level

Package Contents

Before using this Panel PC, please make sure that all the items listed below are present in your package:

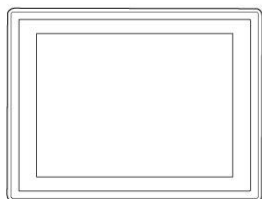

Panel PC

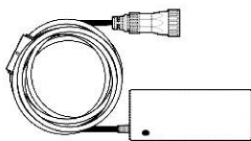

AC to DC adapter

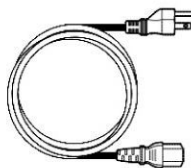

Power cord

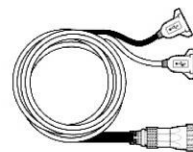

USB cable



USB adapter
(USB Type A to Type B)



Ethernet cable



Ethernet extension
adapter

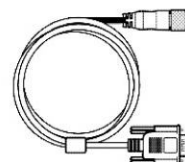

RS-232 cable

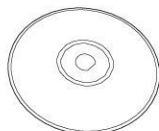

Recovery DVD

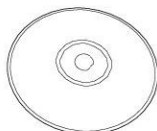

Touch driver CD



VESA mounting
screws

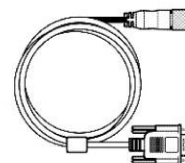

VGA cable



User's manual



Quick start guide

Product Overview

Front View

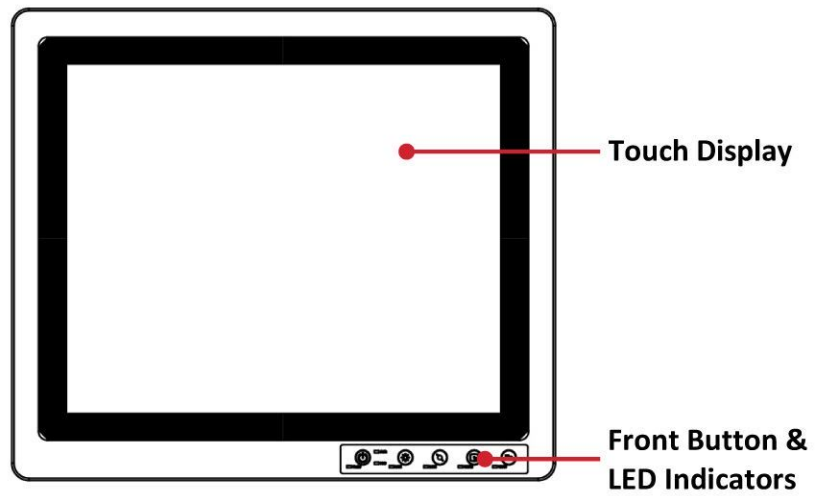

Side and Rear Views

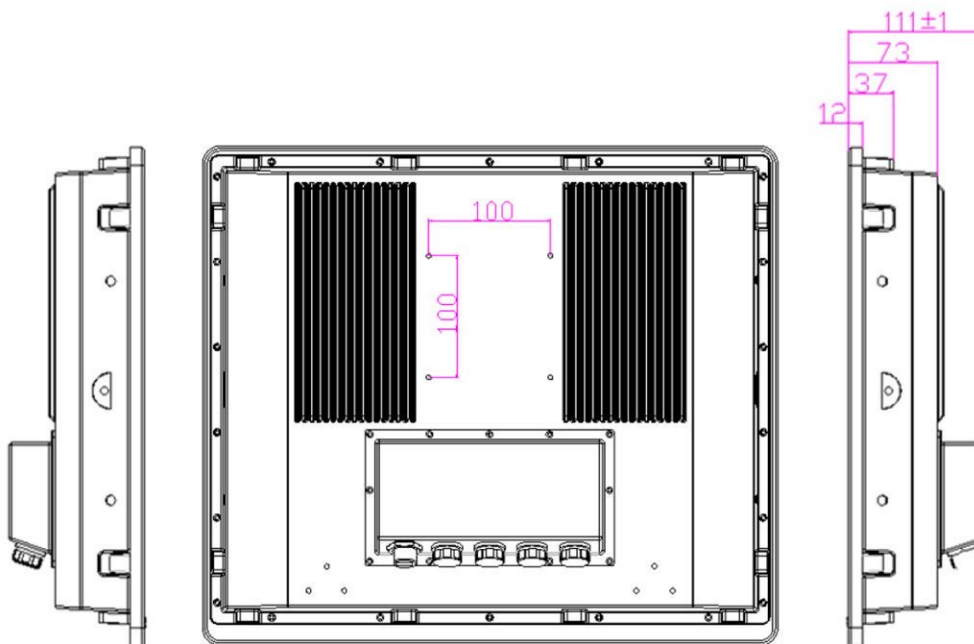

Front Button



Button Type	Function
	Power on/off
	Increase the brightness of the Panel
	Decrease the brightness of the Panel
	Suspend the touch's function temporarily
	Programmable function key configured by Hot Tab Utility

Getting Started

Turning On Your Device

1. Remove the protective cap of the DC IN jack.

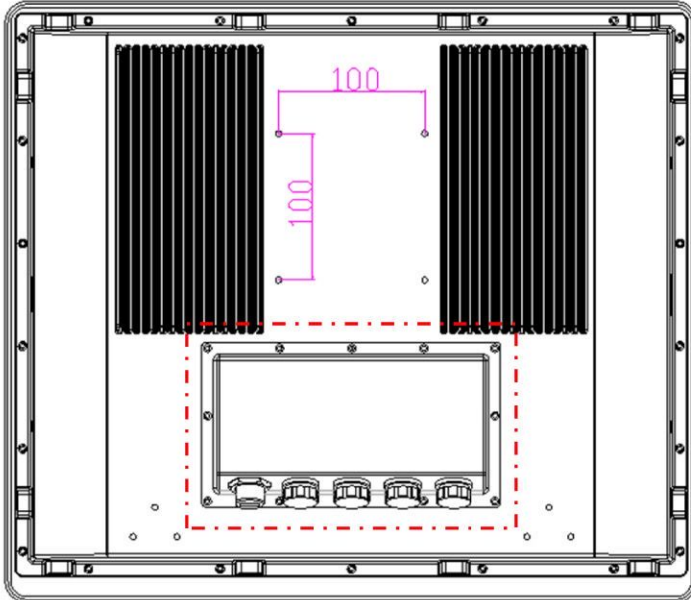

2. Connect the AC adapter to the power cord.
3. Plug the power cord to an electrical outlet.
4. Touch the Power button on the front to turn on the device.

Note

- When the system hangs, press the **Reset** button to restart the device.

Adjusting the LCD Display Brightness

1. Tap the arrow on the system tray to display the hidden icons.
2. Double-tap the  icon to display the brightness menu.



3. Drag the brightness bar to adjust the brightness level according to your preference.

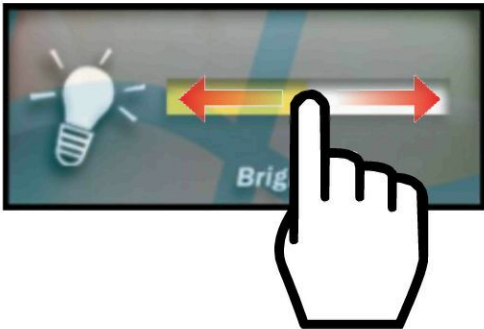

Calibrating Touch Screen

When turning on the Panel PC for the first time, it is highly recommended to calibrate the touch screen to ensure touch accuracy.

Five-wire resistive touchscreens

The five-wire resistive touchscreens use a glass panel with a uniform resistive coating. A thick polyester coversheet is tightly suspended over the top of the glass, separated by small, transparent insulating dots. The coversheet has a hard, durable coating on the outer side and a conductive coating on the inner side.



When the screen is touched, the conductive coating makes electrical contact with the coating on the glass. The voltages produced are the analog representation of the position touched. The controller digitizes these voltages and transmits them to the computer for processing. The five-wire technology utilizes the bottom substrate for both X and Y-axis measurements. The flexible coversheet acts only as a voltage-measuring probe. This means the touchscreen will continue working properly even with non-uniformity in the cover sheet's conductive coating. The result is an accurate, durable and reliable touchscreen that offers drift free operation. The touchscreens are sealed against contamination and moisture. The coversheet is sealed to the glass substrate with an industrial grade caulk. This prevents wicking of fluid between the coversheet and glass. Also, the touchscreens are not air vented, thereby preventing fluid ingress through an air vent.

Brief Specifications

Subject	Details
Input Method	Finger, gloved hand, or stylus activation
Positional Accuracy	Standard deviation error is less than 0.080 (2 mm)
Resolution	Touch point density is based on controller resolution of 4096 x 4096
Touch Activation Force	Typically less than 4 ounces (113 grams)
Light Transmission	HL products: 80% +/-5% at 550 nm wavelength Enhanced products: 60% +/-5% at 550 nm wavelength

Update touch-screen driver or new information. Go to www.elotouch.com.

Elo Touch Correction

Winmate ELO Touch driver software provides a consistent software interface among all ELO touch screens and controllers.

Go to <http://www.elotouch.com/Support/dnld.asp> for a complete list of available supports.

After the driver installation is complete, do the following to perform touch screen calibration.

1. Tap the arrow on the system tray to display the hidden icons.
2. Double-tap the  icon to display the Elo Touchscreen menu.

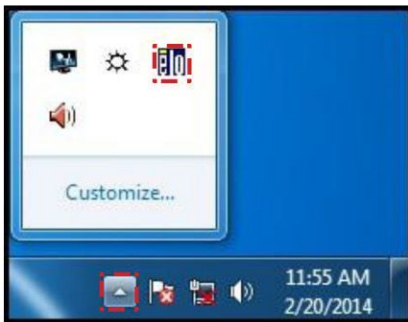

3. Double-tap the  icon to proceed to next step.

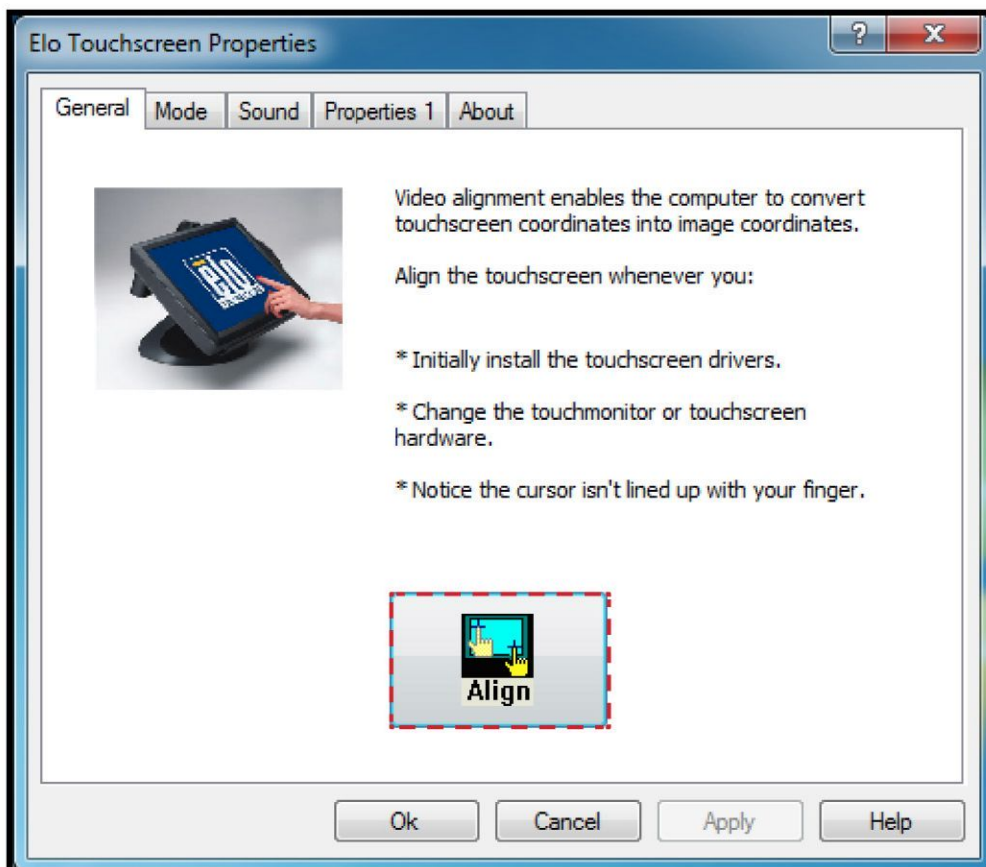

4. Follow the on-screen instructions to calibrate the touch screen.

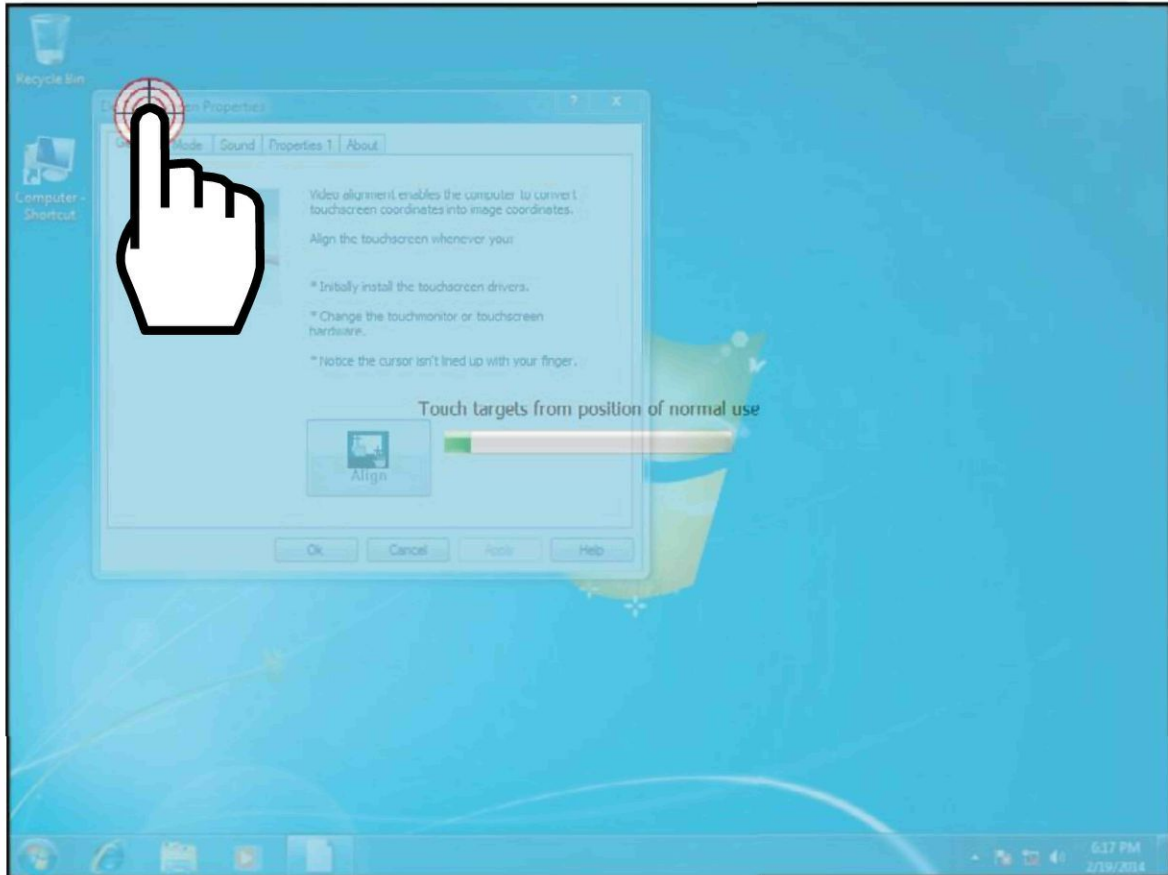

5. Tap the  icon if the cursor follows your finger to finish and exit the calibration utility.

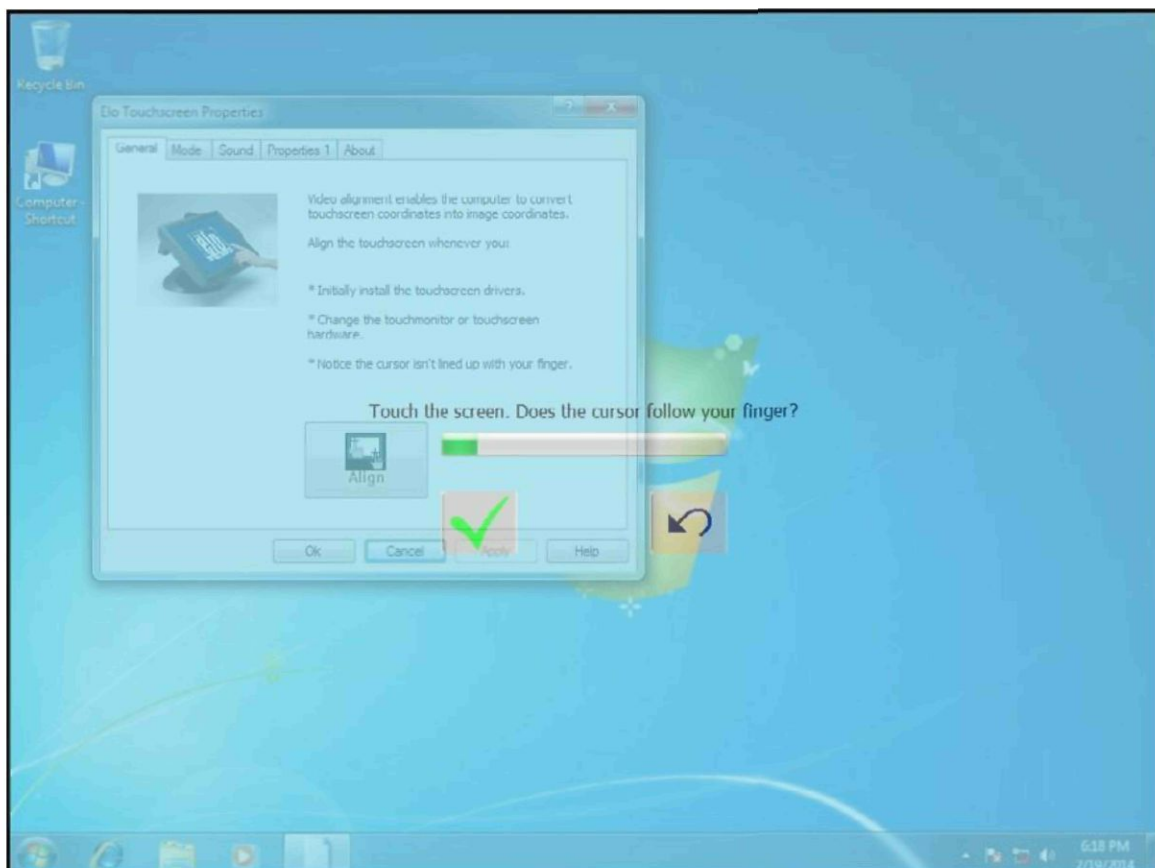

Turning Off Your Device

To shut down your device, do the following: Tap **Start** () > **Shut down**.

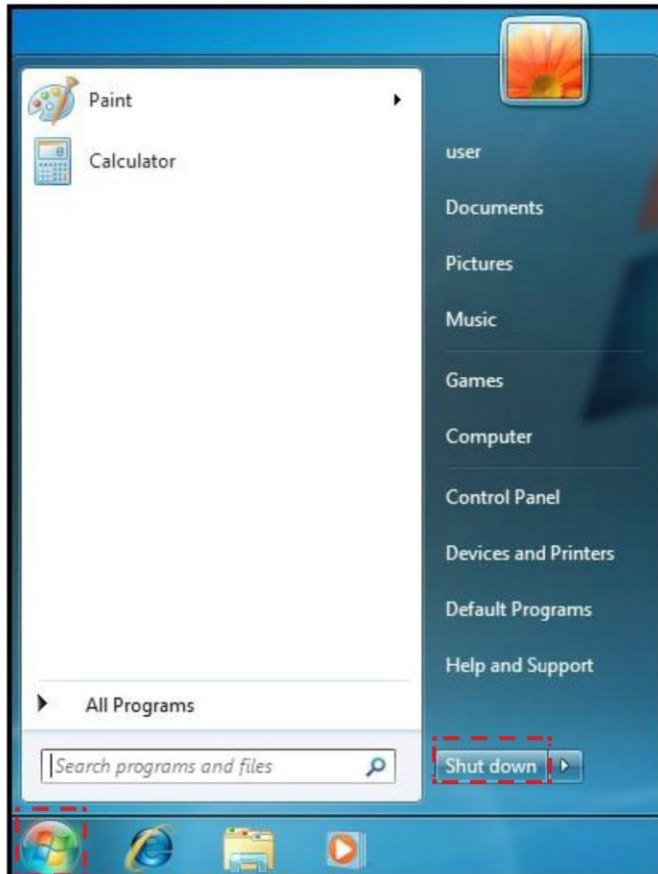

Wait for your Panel PC to completely turn off before disconnecting the power cord (if necessary).

Installation

Wiring Requirements

The following common safety precautions should be observed before installing any electronic device:

- Strive to use separate, non-intersecting paths to route power and networking wires. If power wiring and device wiring paths must cross make sure the wires are perpendicular at the intersection point.
- Keep the wires separated according to interface. The rule of thumb is that wiring that shares similar electrical characteristics may be bundled together.
- Do not bundle input wiring with output wiring. Keep them separate.
- When necessary, it is strongly advised that you label wiring to all devices in the system.



ATTENTION

- Do not run signal or communication wiring and power wiring in the same conduit. To avoid interference, wires with different signal characteristics (i.e., different interfaces) should be routed separately.
- Be sure to disconnect the power cord before installing and/or wiring your device.
- Verify the maximum possible current for each wire gauge, especially for the power cords. Observe all electrical codes dictating the maximum current allowable for each wire gauge.
- If the current goes above the maximum ratings (80 W), the wiring could overheat, causing serious damage to your equipment.
- Be careful when handling the unit. When the unit is plugged in, the internal components generate a lot of heat which may leave the outer casing too hot to touch.

Connecting the Interface

The unit is available with different pass through IP67 connector for cable connections (required to maintain enclosure protection rating). These IP67 connectors are water and gas tight and must be tightened with a torque described in the gland manufacturer’s instructions provided with the unit. Cables must be passed through the connector and wired to the associated I/O connectors.

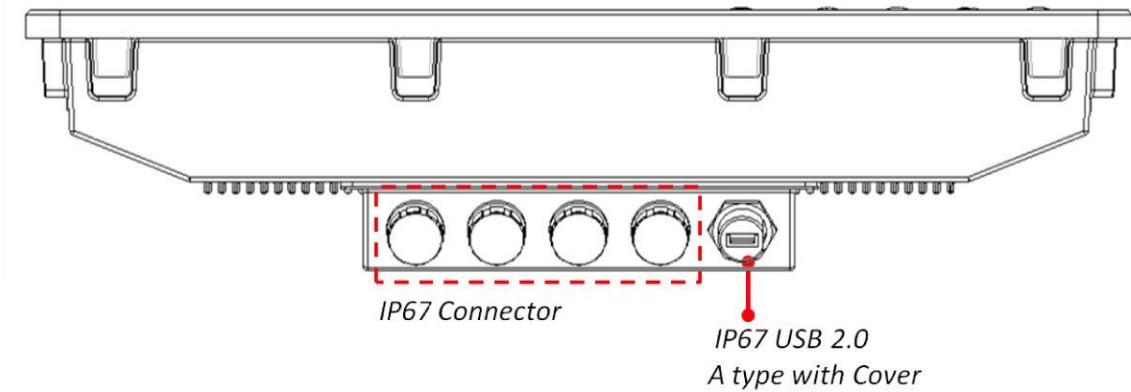

Pin Assignments

The pin assignments of the connectors are as follows:

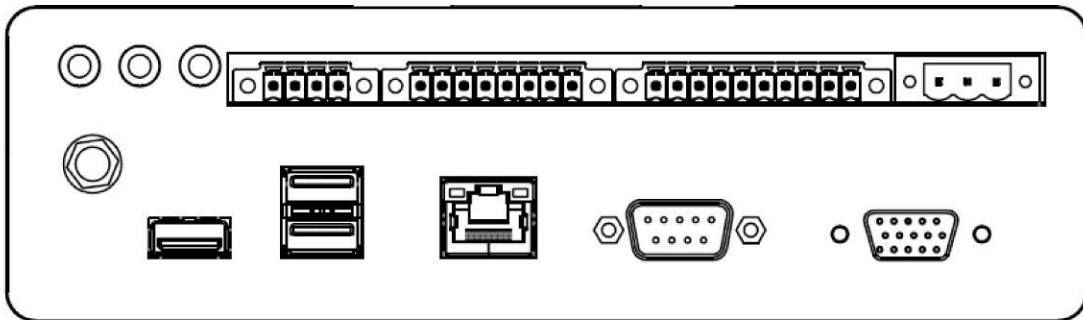

VGA Port

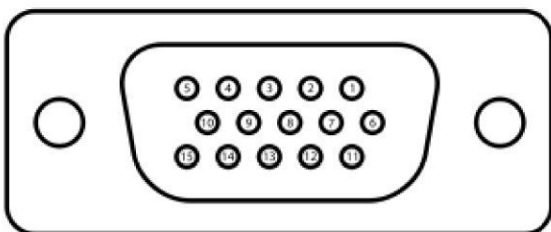

Pin	Signal Name	Pin	Signal Name
1	R_FILTER	2	G_FILTER
3	B_FILTER	4	NC
5	GND	6	GND
7	GND	8	GND
9	VGA5V	10	GND
11	NC	12	DAC_SDAT0
13	3VHSYNCO	14	3VVSYNCO
15	DAC_SCL0		

COM Port

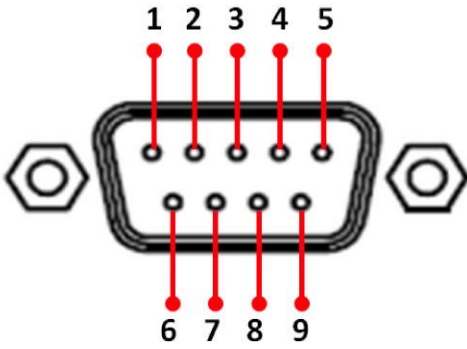

Pin	Signal Name	Pin	Signal Name
1	DCD	2	RXD
3	TXD	4	DTR
5	GND	6	DSR
7	RTS	8	CTS
9	RI		

USB Port

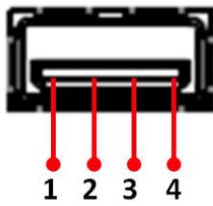

Pin	Signal Name
1	VCC
2	D-
3	D+
4	GND

LAN1 Port

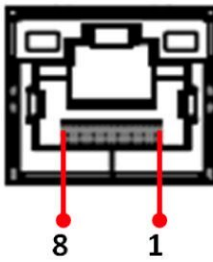

Pin	Signal Name	Pin	Signal Name
1	MDIO_IN+	2	MDIO_IN-
3	MDI1_IN+	4	MDI2_IN+
5	MDI2_IN-	6	MDI1_IN-
7	MDI3_IN+	8	MDI3_IN-

Power terminal block

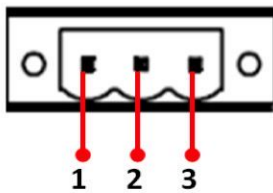

Pin	Signal Name
1	VCC
2	GND
3	NC

COM Port



Pin	Signal Name	Pin	Signal Name
1	DCD	2	RXD
3	TXD	4	DTR
5	GND	6	DSR
7	RTS	8	CTS
9	RI	10	+V5

LAN2 Port



Pin	Signal Name	Pin	Signal Name
1	MDIO3-	2	MDIO3+
3	MDIO2-	4	MDIO2+
5	MDIO1-	6	MDIO1+
7	MDIO0-	8	MDIO0+

USB Port

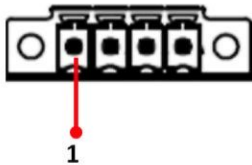

Pin	Signal Name
1	VCC
2	D-
3	D+
4	GND

Note

- This adapter was certified by UL, CUL TUV/GS CE, FCC, BSMI, EK, DOIR+C- TICK, CCC, PSE.

WARNING



Ensure that the external power source is OFF before connecting or disconnecting the DC IN jack.

Mounting Solution

VESA Mount

- **Dimensions:** 100 x 100mm
- **Screw Hole Diameter:** M4 x 5 mm
- **Direction:**
Compatible with swimming arms mounting kits.

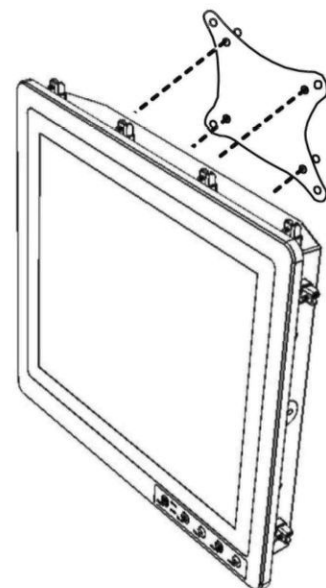

Rear Mount

Before you start installing the rear mount, be sure that you have the following components:

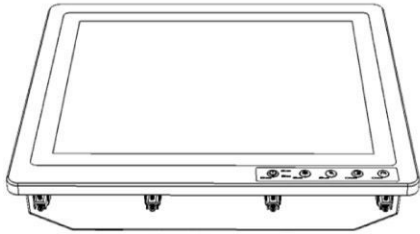

19" Stainless Steel LCD

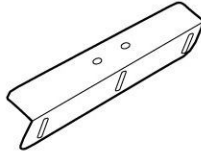

2 x Bracket

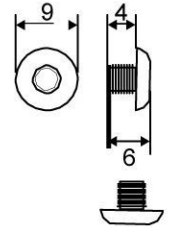

M4, 4mm Screws

To install the rear mount, perform the following:

1. Prepare a customized fixture for 19" panel pc/display.

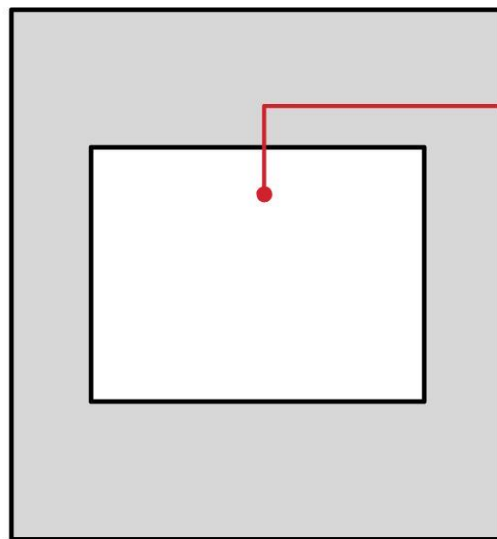

Match the active display area of your rear mount display

2. Screw the brackets on both sides of your device.

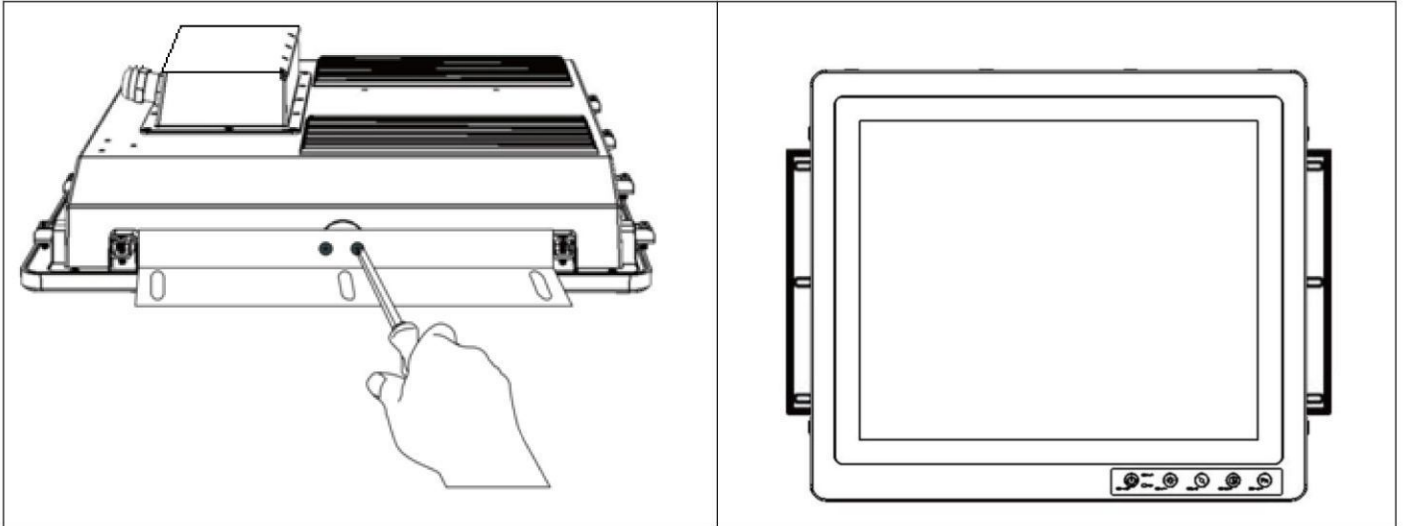

3. Secure the display from the back side first, so the outer frame can be fully covered to ensure the safety of your display.

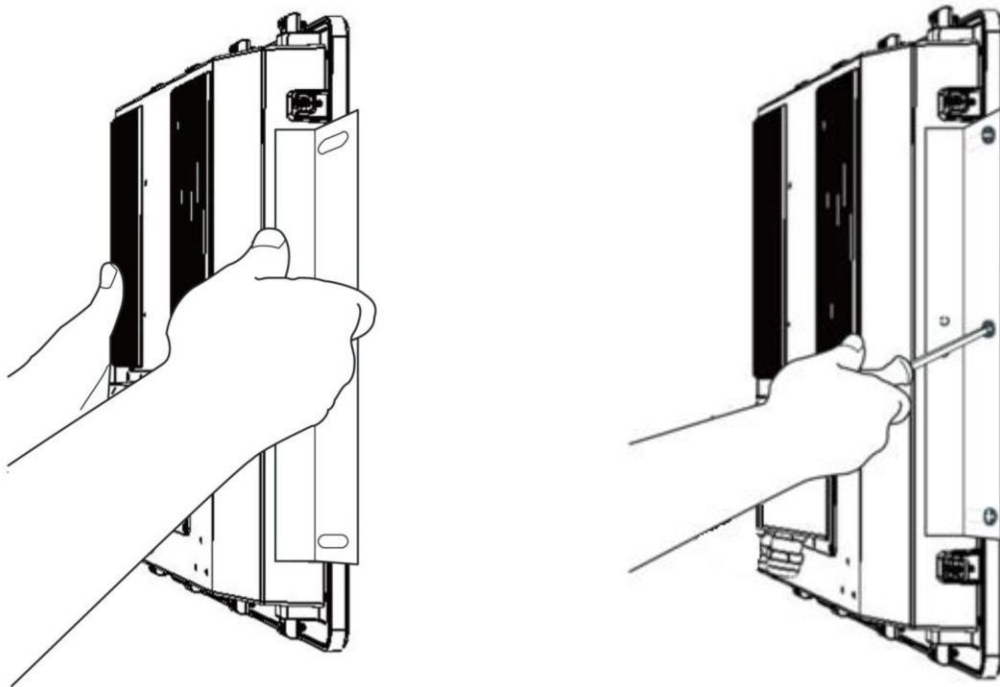

4. Make sure your screws are tight and on the right position.

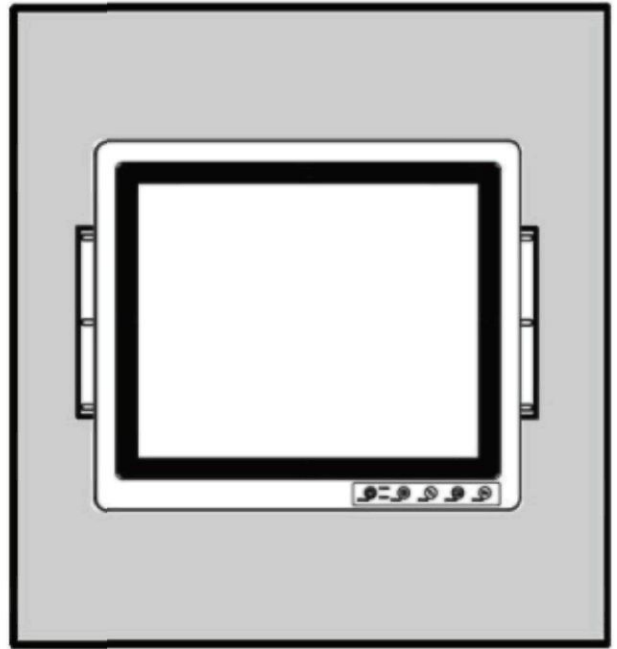
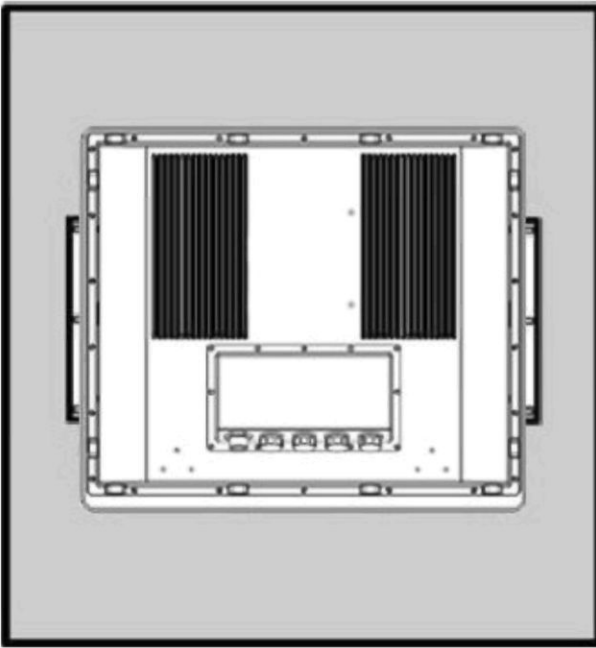

Specification

Hardware Specifications

Item	Specifications
Computer	
CPU	Intel i5-4300u turbo Max 2.9GHz
OS	Windows 7 embedded systems
System Chipset	Intel® HD graphics 5000
Bios	AMI 16Mbit Flash
System Memory	8GB capacity, 4GB pre-installed
USB	3 x USB 3.0
Storage	
Storage Support	Removable 128GB industrial grade SSD to store OS; support up to 256GB
Display	
Panel Size	19-inch 1280 x 1024, 800nit LED backlight LCD
Contrast Ratio	1000:1
Response Time	10ms
View Angles	<ul style="list-style-type: none">• Horizontal: 170 degree (left to right)• Vertical: 160 degree (up to down)
Max Colors	16.7M colors
Touch	Flat Resistive single point touch, suitable for use outdoors around heavy equipment
Ethernet Interface	
Hardware Interface	1 x RJ45; 1 x 8pins terminal block
Serial Interface	
Serial Standard	1x DB9 RS232; 1 x 10pins terminal block
Power Requirements	
Input Voltage	Typical 9~36V DC (isolation 1.5V)

Item	Specifications
Physical Characteristics	
Housing	Stainless steel
Dimensions	396 x 310 x 49mm (W x H x D)
Mounting	Mounting hole for VESA 100 x 100, yoke mounting
Environment Limits	
Operating Temperature	-40°C to 60°C
Storage Temperature	-40°C to 80°C
Ambient Relative Humidity	5 to 95% (non-condensing)

Appendix

Appendix A: Cleaning the Monitor

Before cleaning:

- Make sure the device is turned off.
- Disconnect the power cable from any AC outlet.

When cleaning:

- Never spray or pour any liquid directly on the screen or case.
- Wipe the screen with a clean, soft, lint-free cloth. This removes dust and other particles.
- The display area is highly prone to scratching. Do not use ketene type material (ex. Acetone), Ethyl alcohol, toluene, ethyl acid or Methyl chloride to clear the panel. It may permanently damage the panel and void the warranty.
- If it is still not clean enough, apply a small amount of non-ammonia, non-alcohol based glass cleaner onto a clean, soft, lint-free cloth, and wipe the screen.
- Do not use water or oil directly on the display screen. If droplets are allowed to drop on the screen, permanent staining or discoloration may occur.

Appendix B: Statement of Regulatory Approval

Refer the following descriptions for various approvals and certifications

Low Voltage Directive European Safety for Industrial Control Equipment



Self-Declaration in accordance with European LVD Directive 2006/95/EC; Independent 3rd party assessment (Accredited by IEC 17025)

Electromagnetic Compatibility Directive European EMC for Industrial Control Equipment



Self-Declaration in accordance with EMC Directive 2004/108/EC; Independent 3rd party assessment (Accredited by IEC 17025)